



BLASTMASTER® 950 CFM AFTERCOOLER WITH COALESCING TANK



BUILT MARCO TOUGH
MARCO MANUFACTURED

PART NUMBERS AND SCHEMATICS GUIDE

Company Profile

Since 1944, Marco has developed a strong tradition of providing innovative and reliable products and services to the surface preparation and protective coatings industries. We are the world's premier provider of Abrasives, Blasting, Coating, Dust Collectors, Engineered Systems, Rental, Safety, Service, Repair, & Modernization, and Vacuums.

Through innovative designs and a total commitment to quality, Marco manufactures products that increase production rates, create a safer workplace, and reduce maintenance costs. Marco's industry experience, manufacturing capabilities, legendary customer service, product availability, logistics services, and technology leadership is your assurance that we deliver high quality products and services, providing the best value to you, our customer.

The Marco Difference

- **Industry Experience** – With Marco on your team, you have access to expertise which can only come from decades of industry leadership. We have organized our engineering department, production specialists, customer operations, and safety support into a “Center of Competence.” As a Marco customer, you have access to hundreds of years of cumulative experience related to your operations.
- **Manufacturing Excellence** – Marco is a U.S. based, ISO 9001:2008 certified manufacturer of equipment for the Surface Preparation and Protective Coatings industries. Marco's engineers benchmark the industry to ensure that we design and manufacture superior products that set the “Gold Standard” for performance, safety, and quality.
- **Legendary Customer Service** – Marco's legendary customer service team is staffed by friendly, highly-trained individuals who are focused on providing the highest level of product support, order accuracy, and customer satisfaction.
- **Product Availability** – We stock over 10,000 SKU's and have more than 45 shipping locations to serve North American and International markets for all major brands of blasting and coating equipment. As the largest provider of surface preparation and protective coatings equipment in the world, our inventory levels and product availability are unmatched.
- **Logistics Services** – Marco's in-house logistics team is dedicated to moving your shipment anywhere in the world. We move more than 14,000 truckloads every year, allowing you to save on freight costs by leveraging our buying power. Lower your process costs with a single invoice, which includes product and freight.
- **Technology Leadership** – Our website provides: Operator's Manuals, Part Numbers and Schematics Guides, SDS information, and Features & Specifications Guides, providing access to information 24/7. Our Extranet application allows you to receive quotes and place orders online. Our Intranet maintains a complete record of your purchase history to assist with ongoing support of your existing equipment and future purchasing decisions.

Vision Statement

Marco is the world's premier provider of Abrasives, Blasting, Coating, Dust Collectors, Engineered Systems, Rental, Safety, Service, Repair, & Modernization, and Vacuums.

Mission Statement

Marco provides strong leadership and innovation to the surface preparation and protective coatings industries. We dedicate our efforts to the continuous improvement of our products, services, processes, people, and most importantly, the quality of our customer's experience.

Quality Statement

Marco is committed to providing superior quality in the design, manufacturing, distribution, rental, service, and repair of our products. Our ISO 9001:2008 certification extends throughout all operations in all locations. Continuous improvement of our processes and supply chain Integration comprise the core of our business strategy for delivering exceptional quality and value in all Marco products and services.

Management Philosophy

We are a company dedicated to the success of every customer and associate. We discuss, debate, challenge, measure, and test our ideas. We will be boundless and limitless in our passion to improve. Through sound leadership and dedicated associates, we will ensure a long term, profitable future for Marco, our associates, customers, and suppliers.

TABLE OF CONTENTS

Company Profile	2
Table of Contents	3
Part Numbers	4-5
Specifications	6-7
Part Numbers & Schematics	8-24
Blastmaster® 950 CFM Aftercooler With Coalescing Tank—Pneumatic	8-9
Blastmaster® 950 CFM Offshore Aftercooler With Coalescing Tank—Pneumatic	10-11
Blastmaster® 950 CFM Aftercooler With Coalescing Tank—115 Volt Electric	12-13
Blastmaster® 950 CFM Aftercooler With Coalescing Tank—230 Volt Electric	14-15
Blastmaster® 950 CFM Offshore Aftercooler With Coalescing Tank—115 Volt Electric	16-17
Blastmaster® 950 CFM Offshore Aftercooler With Coalescing Tank—230 Volt Electric	18-19
Aftercooler Assembly—Pneumatic	20
Aftercooler Assembly—Electric	21
Transfer Hose Assembly	22
Inlet Filter Assembly	23
Air Filter/Regulator/Lubricator	24
Optional Accessories	25-26
Airflow Shutoff Kits – Lug Fittings	25
Airflow Shutoff Kits – Hammerlock Fittings	25
Pipe Plugs	26
Lubrication	26
Maintenance Notes	27

PART NUMBERS

BLASTMASTER® 950 CFM AFTERCOOLER WITH COALESCING TANK									
Part Numbers	Inlet			Outlet			Power Source	Filter, Regulator, and Lubricator	Electric Starter Box
	Inlet Quantity	Inlet Size	Fittings	Outlet Quantity	Outlet Size	Fittings			
10101150	1	3"	Not Included	9	(2) 3", (2) 2", (1) 1-1/4", (4) 1"	Not Included	Pneumatic	Included	Not Included
10108805	1	3"	Not Included	9	(2) 3", (2) 2", (1) 1-1/4", (4) 1"	Not Included	115-Volt AC	Not Included	Included
10101151	1	3"	Not Included	9	(2) 3", (2) 2", (1) 1-1/4", (4) 1"	Not Included	230-Volt AC	Not Included	Included



10101150



10101151 & 10108805

PART NUMBERS

BLASTMASTER® 950 CFM OFFSHORE AFTERCOOLER WITH COALESCING TANK

Part Numbers	Inlet			Outlet			Power Source	Filter, Regulator, and Lubricator	Electric Starter Box
	Inlet Quantity	Inlet Size	Fittings	Outlet Quantity	Outlet Size	Fittings			
10102585	1	3"	Not Included	9	(2) 3", (2) 2", (1) 1-1/4", (4) 1"	Not Included	Pneumatic	Included	Not Included
10108816	1	3"	Not Included	9	(2) 3", (2) 2", (1) 1-1/4", (4) 1"	Not Included	115-Volt AC	Not Included	Included
10102586	1	3"	Not Included	9	(2) 3", (2) 2", (1) 1-1/4", (4) 1"	Not Included	230-Volt AC	Not Included	Included



10102585



10102586 & 10108816

SPECIFICATIONS

Lubrication: SAE 10 oil or Air Tool Anti-freeze Lubricant

Empty Weight: 1200 Pounds

Overall Dimensions: A: 89"
B: 35"
C: 72"

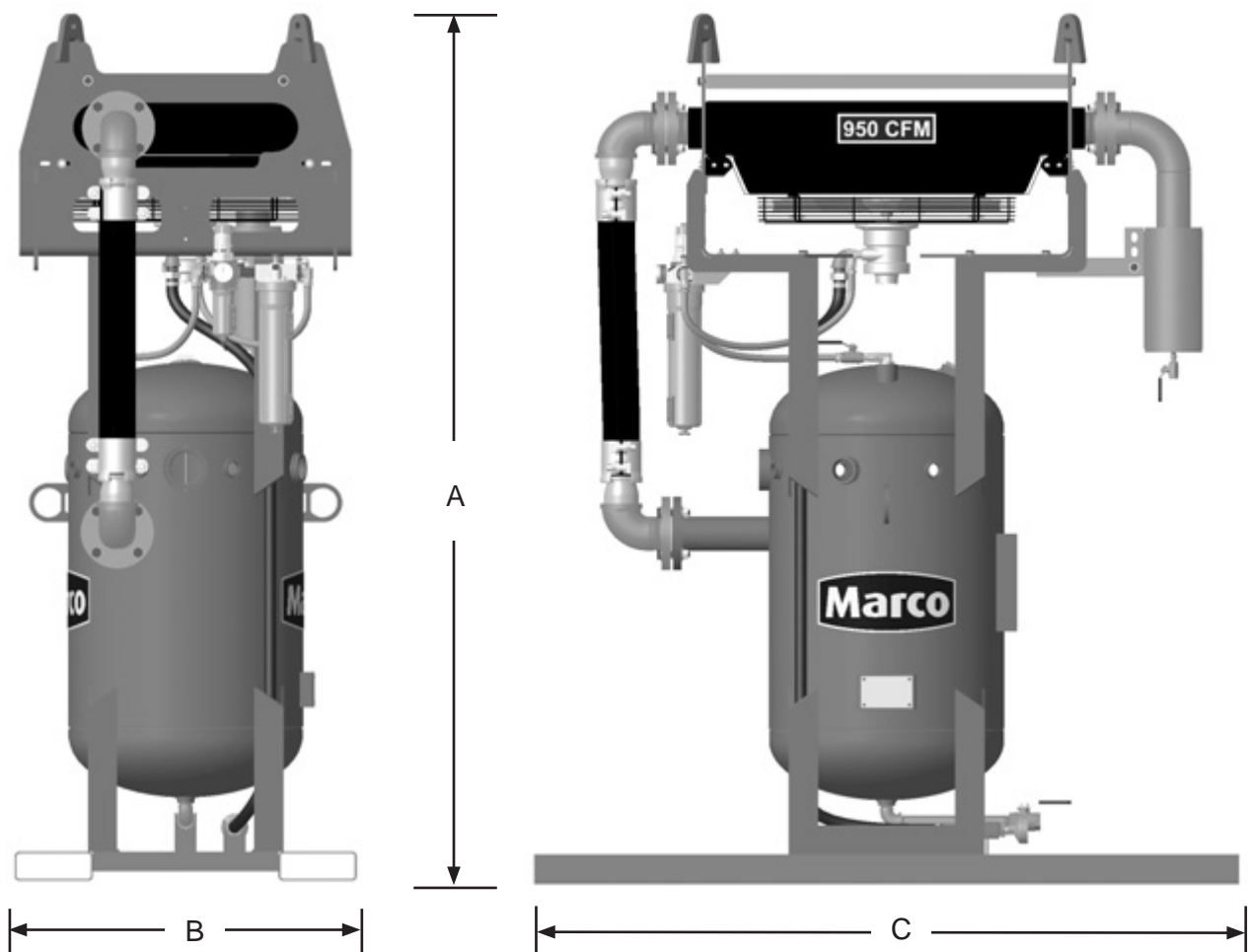

Blastmaster® 950 CFM Aftercooler with Coalescing Tank
Pneumatic model shown, Electric model is same.

SPECIFICATIONS

Lubrication: SAE 10 oil or Air Tool Anti-freeze Lubricant

Empty Weight: 1200 Pounds

Overall Dimensions: A: 92"
B: 39"
C: 72"

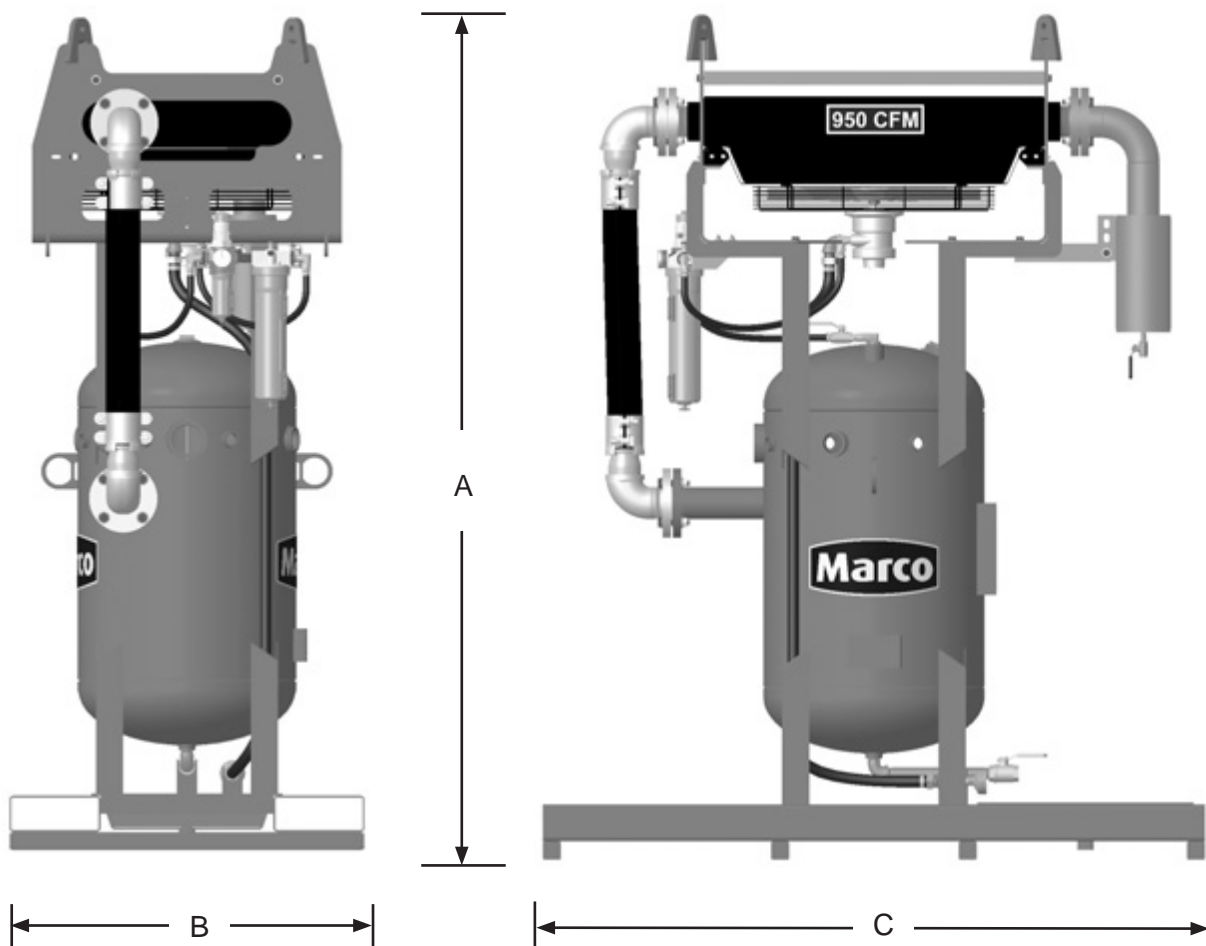

Blastmaster® 950 CFM Offshore Aftercooler with Coalescing Tank
Pneumatic model shown, Electric model is same.

PART NUMBERS & SCHEMATICS

Blastmaster® 950 CFM Aftercooler With Coalescing Tank—Pneumatic

Item #	Part #	Description	Item #	Part #	Description
Fig. 1					
—	10101150	Blastmaster® 950 CFM Aftercooler with Coalescing Tank – Pneumatic	24	10AH100B	1" I.D. Air Hose (<i>Per Foot</i>)
1	10105890	Filter/Regulator/Lubricator with Pressure Gauge (<i>See Fig. 11</i>)	25	10L363	1/2" NPT Full Port Ball Valve
2	10101033	Heat Exchanger Mounting Bracket (<i>Two Required</i>)	26	10AH012	1/2" I.D. Air Hose (<i>Per Foot</i>)
3	10101943	1/2-13 x 1-3/4" Bolt Galvanized (<i>10 Required</i>)	27	10PAF050	1/2" Push-on Hose Fitting (<i>Four Required</i>)
4	10100674	1/2" Flat Washer Galvanized (<i>20 Required</i>)	28	10SAP1290	1/2" 90° Swivel (<i>Four Required</i>)
5	10100675	1/2" Split Lock Washer Galvanized (<i>10 Required</i>)	29	20100677	1/2" x 1/2" Nipple (<i>Two Required</i>)
6	10101941	1/2-13 Hex Nut Galvanized (<i>10 Required</i>)	30	10AHCL1	Band Clamp (<i>Two Required</i>)
7	10101166	Heat Exchanger Protective Grate	31	—	Transfer Hose Assembly (<i>See Fig. 9</i>)
8	10TTHP9505	Aftercooler Assembly - Complete (<i>See Fig. 7</i>)	32	10107495	1/2-13 x 1-5/8" Grade 8 Hex Bolt Zinc (<i>Four Required</i>)
9	10101059	3/8-16 x 1-1/4" Bolt Galvanized (<i>Four Required</i>)	33	10107496	1/2-13 Grade 8 Lock Nut Zinc (<i>Four Required</i>)
10	10101942	3/8" Flat Washer Galvanized (<i>Eight Required</i>)	34	10104711	1/2" Grade 8 Flat Washer Zinc (<i>Eight Required</i>)
11	10L805015	3/8" Lock Washer Galvanized (<i>Four Required</i>)	35	10101024	Skid Weldment
12	10101938	3/8-16 Hex Nut Galvanized (<i>Four Required</i>)	36	10108281	Mounting Bracket
13	—	Inlet Filter Assembly (<i>See Fig. 10</i>)	37	10105903	1/4-20 x 1-1/4" Hex Bolt (<i>Four Required</i>)
14	10101034	3" NPT Galvanized Pipe Plug	38	10101940	1/4" Flat Washer (<i>12 Required</i>)
15	10101002	1/2" x 1" NPT Reducing Elbow	39	10101939	1/4-20 Stainless Steel Lock Nut with Nylon Insert (<i>Four Required</i>)
16	1011902	1-1/4" NPT Plug	40	10109052	U-Bolt (<i>Two Required</i>)
17	1011801	1" NPT Street Elbow	41	1094537	950 CFM Product Sticker
18	1011812	1" (M) x 1/2" (F) NPT Bushing	—	1070517	Pneumatic Tool Oil — 32 oz.
19	10101064	1" x 12" NPT Pipe Nipple	—	1091017	Hazard Identification Tag
20	1011601	1" NPT Full Port Ball Valve	—	106M078	Part Numbers and Schematics Guide – Blastmaster® 950 CFM Aftercooler with Coalescing Tank
21	10101800	Aftercooler Exhaust Muffler – 950 CFM–1600 CFM	—	1090078	Operator's Manual – Blastmaster® 950 CFM Aftercooler with Coalescing Tank
22	1012151	1" NPT Close Nipple (<i>Two Required</i>)			
23	10SFE2	1" NPT Swivel Hose End (F) (<i>Two Required</i>)			

PART NUMBERS AND SCHEMATICS

Figure 1: Blastmaster® 950 CFM Aftercooler With Coalescing Tank—Pneumatic

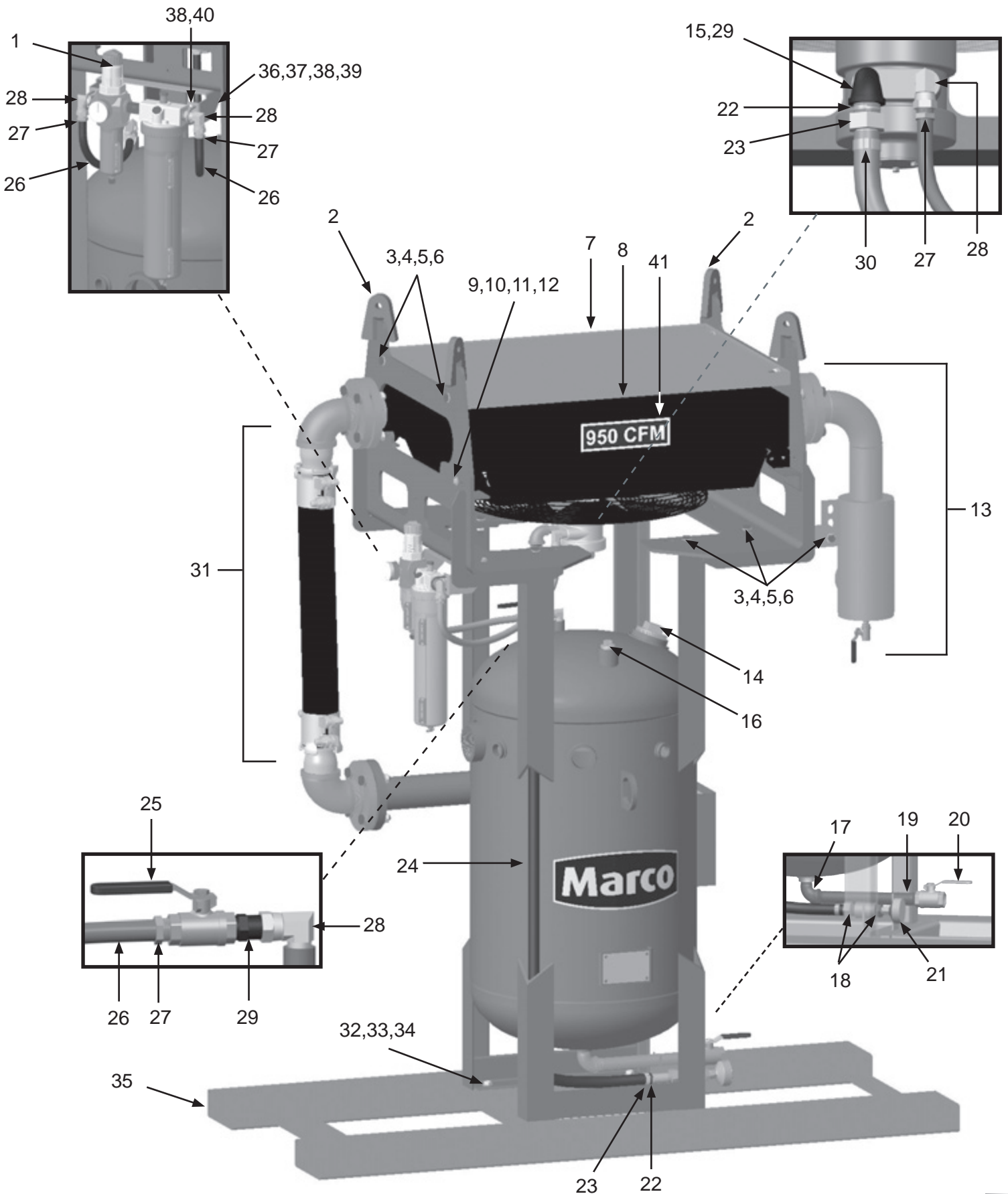

PART NUMBERS AND SCHEMATICS

Blastmaster® 950 CFM Offshore Aftercooler With Coalescing Tank—Pneumatic

Item #	Part #	Description
Fig. 1		
—	10102585	Blastmaster® 950 CFM Offshore Aftercooler with Coalescing Tank – Pneumatic
1	10105890	Filter/Regulator/Lubricator with Pressure Gauge (<i>See Fig. 11</i>)
2	10101033	Heat Exchanger Mounting Bracket (<i>Two Required</i>)
3	10101943	1/2-13 x 1-3/4" Bolt Galvanized (<i>10 Required</i>)
4	10100674	1/2" Flat Washer Galvanized (<i>20 Required</i>)
5	10100675	1/2" Split Lock Washer Galvanized (<i>10 Required</i>)
6	10101941	1/2-13 Hex Nut Galvanized (<i>10 Required</i>)
7	10101166	Heat Exchanger Protective Grate
8	10TTHP9505	Aftercooler Assembly - Complete (<i>See Fig. 7</i>)
9	10101059	3/8-16 x 1-1/4" Bolt Galvanized (<i>Four Required</i>)
10	10101942	3/8" Flat Washer Galvanized (<i>Eight Required</i>)
11	10L805015	3/8" Lock Washer Galvanized (<i>Four Required</i>)
12	10101938	3/8-16 Hex Nut Galvanized (<i>Four Required</i>)
13	—	Inlet Filter Assembly (<i>See Fig. 10</i>)
14	10101034	3" NPT Galvanized Pipe Plug
15	10101002	1/2" x 1" NPT Reducing Elbow
16	1011902	1-1/4" NPT Plug
17	1011801	1" NPT Street Elbow
18	1011812	1" (M) x 1/2" (F) NPT Bushing
19	10101064	1" x 12" NPT Pipe Nipple
20	1011601	1" NPT Full Port Ball Valve
21	10101800	Aftercooler Exhaust Muffler – 950 CFM–1600 CFM
22	1012151	1" NPT Close Nipple (<i>Two Required</i>)
23	10SFE2	1" NPT Swivel Hose End (F) (<i>Two Required</i>)
24	10AH100B	1" I.D. Air Hose (<i>Per Foot</i>)
25	10L363	1/2" NPT Full Port Ball Valve
26	10AH012	1/2" I.D. Air Hose (<i>Per Foot</i>)
27	10PAF050	1/2" Push-on Hose Fitting (<i>Four Required</i>)
28	10SAP1290	1/2" 90° Swivel (<i>Two Required</i>)
29	20100677	1/2" x 1/2" Nipple (<i>Two Required</i>)
30	10AHCL1	Band Clamp (<i>Two Required</i>)
31	—	Transfer Hose Assembly (<i>See Fig. 9</i>)
32	1011901	1" Galvanized Pipe Plug
33	10108281	Mounting Bracket
34	10105903	1/4-20 x 1-1/4" Hex Bolt (<i>Four Required</i>)
35	10101940	1/4" Flat Washer (<i>12 Required</i>)
36	10101939	1/4-20 Stainless Steel Lock Nut with Nylon Insert (<i>Four Required</i>)
37	10109052	U-Bolt (<i>Two Required</i>)
38	1094537	950 CFM Product Sticker
—	1070517	Pneumatic Tool Oil — 32 oz.

PART NUMBERS AND SCHEMATICS

Figure 2: Blastmaster® 950 CFM Offshore Aftercooler With Coalescing Tank—Pneumatic

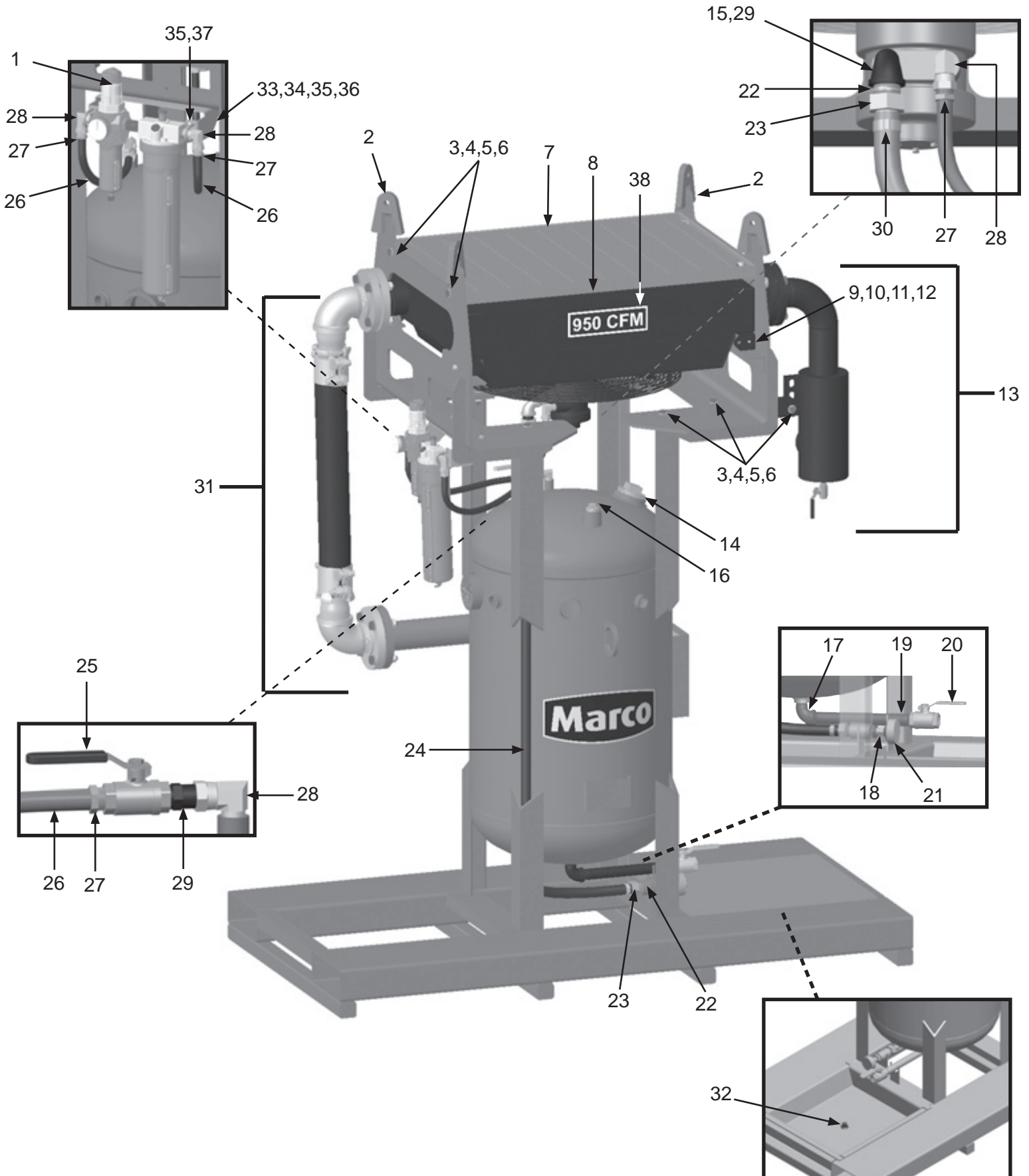

PART NUMBERS AND SCHEMATICS

Blastmaster® 950 CFM Aftercooler With Coalescing Tank—115 Volt Electric

Item #	Part #	Description
Fig. 3		
—	10108805	Blastmaster® 950 CFM Aftercooler With Coalescing Tank – 115 Volt Electric
1	10108792	1 Phase Electric Motor Starter - 3 HP to 5 HP
2	1012154	1/4-20 x 1" Hex Bolt Zinc (<i>Four Required</i>)
3	1014017	1/4" Flat Washer Zinc (<i>Eight Required</i>)
4	10101059	3/8-16 x 1-1/4" Bolt Galvanized (<i>Six Required</i>)
5	10101942	3/8" x 3/4" Flat Washer Galvanized (<i>12 Required</i>)
6	10101943	1/2-13 x 1-3/4" Hex Bolt Galvanized (<i>10 Required</i>)
7	10100674	1/2" Flat Washer Galvanized (<i>20 Required</i>)
8	10100675	1/2" Split Lock Washer Galvanized (<i>10 Required</i>)
9	10101941	1/2-13 Hex Nut Galvanized (<i>10 Required</i>)
10	10101033	Mounting Bracket (<i>Two Required</i>)
11	10101036	Heat Exchanger Protective Grate
12	10TTAHP9502	950 CFM Aftercooler Assembly - Complete (<i>See Fig. 8</i>)
13	10101170	Brace
14	10101034	3" NPT Galvanized Pipe Plug
15	—	Inlet Filter Assembly (<i>See Fig. 10</i>)
16	1011902	1-1/4" NPT Galvanized Pipe Plug
17	10101064	1" x 12" NPT Pipe Nipple
18	1011601	1" NPT Full Port Ball Valve
19	1011801	1" NPT Street Elbow
20	20G100737	1/2" NPT Pipe Plug
21	10103303	3/4" Conduit Hub (<i>Two Required</i>)
22	10L805015	3/8" Lock Washer Galvanized (<i>Six Required</i>)
23	10101938	3/8-16 Hex Nut Galvanized (<i>Six Required</i>)
24	10108830	Motor Starter Bracket
25	—	Transfer Hose Assembly (<i>See Fig. 9</i>)
26	20101197	3/4" NPT Cord Grip
27	10103304	3/4" Flexible Conduit
28	1012323	1/4"-20 Lock Nut Zinc (<i>Four Required</i>)
29	10107495	1/2-13 x 1-5/8" Grade 8 Hex Bolt Zinc (<i>Four Required</i>)
30	10107496	1/2-13 Grade 8 Lock Nut Zinc (<i>Four Required</i>)
31	10104711	1/2" Grade 8 Flat Washer Zinc (<i>Eight Required</i>)
32	10101024	Skid Weldment
33	1094537	950 CFM Product Sticker
—	10108798	Thermal Unit - Full Load Current 16.2 - 17.6 Amps
—	1091017	Hazard Identification Tag
—	106M078	Part Numbers and Schematics Guide – Blastmaster® 950 CFM Aftercooler with Coalescing Tank
—	1090078	Operator's Manual – Blastmaster® 950 CFM Aftercooler with Coalescing Tank

PART NUMBERS AND SCHEMATICS

Figure 3: Blastmaster® 950 CFM Aftercooler With Coalescing Tank—115 Volt Electric

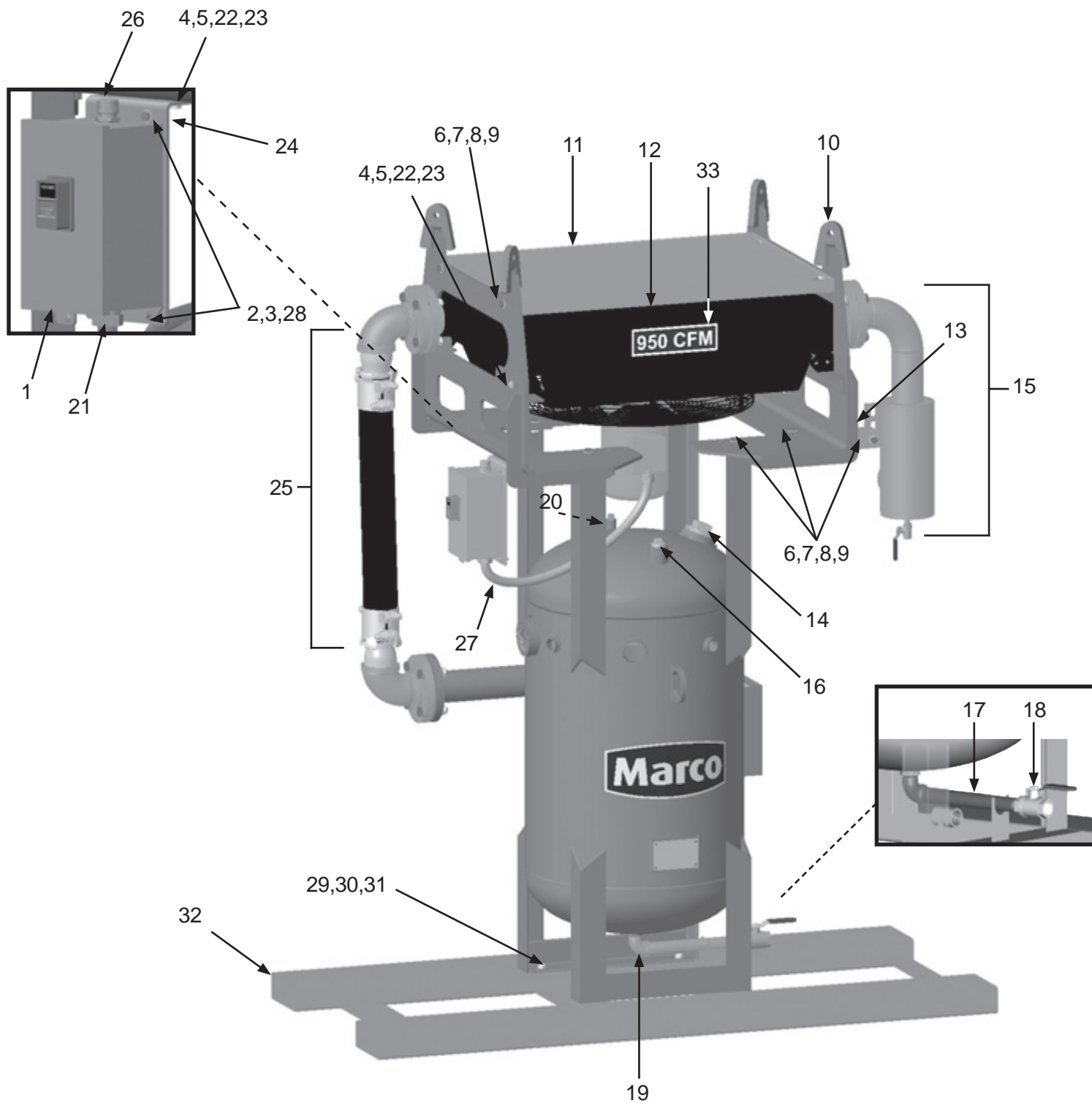

PART NUMBERS AND SCHEMATICS

Blastmaster® 950 CFM Aftercooler With Coalescing Tank—230 Volt Electric

Item #	Part #	Description
Fig. 4		
—	10101151	Blastmaster® 950 CFM Aftercooler With Coalescing Tank – 230 Volt Electric
1	10101760	Electric Motor Starter Box – Single Phase
2	1012154	1/4-20 x 1" Hex Bolt Zinc <i>(Four Required)</i>
3	1014017	1/4" Flat Washer Zinc <i>(Eight Required)</i>
4	10101059	3/8-16 x 1-1/4" Bolt Galvanized <i>(Six Required)</i>
5	10101942	3/8" x 3/4" Flat Washer Galvanized <i>(12 Required)</i>
6	10101943	1/2-13 x 1-3/4" Hex Bolt Galvanized <i>(10 Required)</i>
7	10100674	1/2" Flat Washer Galvanized <i>(20 Required)</i>
8	10100675	1/2" Split Lock Washer Galvanized <i>(10 Required)</i>
9	10101941	1/2-13 Hex Nut Galvanized <i>(10 Required)</i>
10	10101033	Mounting Bracket <i>(Two Required)</i>
11	10101036	Heat Exchanger Protective Grate
12	10TTAHP9502	950 CFM Aftercooler Assembly - Complete <i>(See Fig. 8)</i>
13	10101170	Brace
14	10101034	3" NPT Galvanized Pipe Plug
15	—	Inlet Filter Assembly <i>(See Fig. 10)</i>
16	1011902	1-1/4" NPT Galvanized Pipe Plug
17	10101064	1" x 12" NPT Pipe Nipple
18	1011601	1" NPT Full Port Ball Valve
19	1011801	1" NPT Street Elbow
20	20G100737	1/2" NPT Pipe Plug
21	10103303	3/4" Conduit Hub <i>(Two Required)</i>
22	10L805015	3/8" Lock Washer Galvanized <i>(Six Required)</i>
23	10101938	3/8-16 Hex Nut Galvanized <i>(Six Required)</i>
24	10108830	Motor Starter Bracket
25	—	Transfer Hose Assembly <i>(See Fig. 9)</i>
26	20101299	3/4" NPT Cord Grip
27	10103304	3/4" Flexible Conduit
28	1012323	1/4"-20 Lock Nut Zinc <i>(Four Required)</i>
29	10107495	1/2-13 x 1-5/8" Grade 8 Hex Bolt Zinc <i>(Four Required)</i>
30	10107496	1/2-13 Grade 8 Lock Nut Zinc <i>(Four Required)</i>
31	10104711	1/2" Grade 8 Flat Washer Zinc <i>(Eight Required)</i>
32	10101024	Skid Weldment
33	1094537	950 CFM Product Sticker
—	10108796	Thermal Unit - Full Load Current 8.48 - 9.83 Amps
—	1091017	Hazard Identification Tag
—	106M078	Part Numbers and Schematics Guide – Blastmaster® 950 CFM Aftercooler with Coalescing Tank
—	1090078	Operator's Manual – Blastmaster® 950 CFM Aftercooler with Coalescing Tank

PART NUMBERS AND SCHEMATICS

Figure 4: Blastmaster® 950 CFM Aftercooler With Coalescing Tank—230 Volt Electric

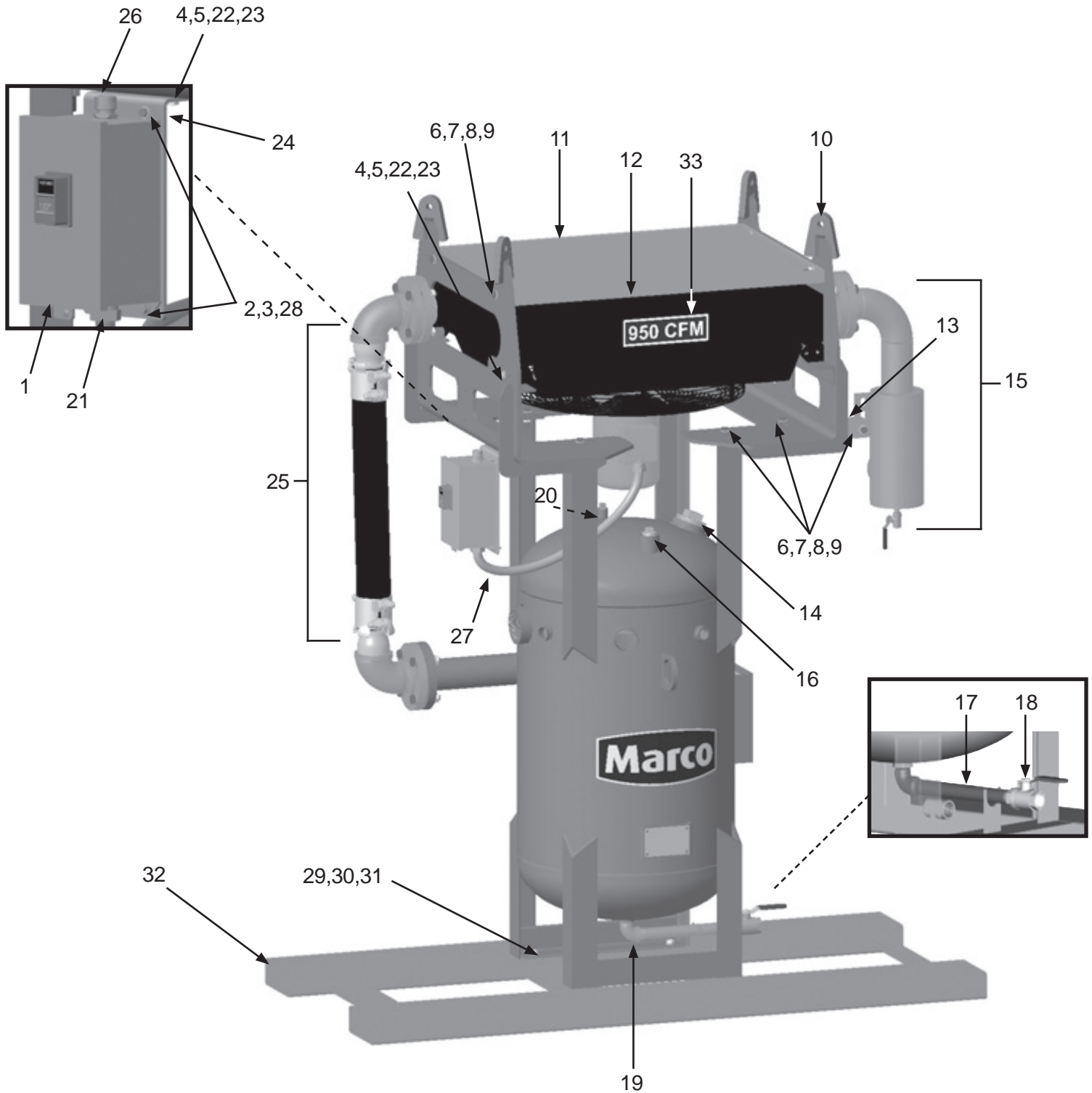

PART NUMBERS AND SCHEMATICS

Blastmaster® 950 CFM Offshore Aftercooler With Coalescing Tank—115 Volt Electric

Item #	Part #	Description
Fig. 5		
—	10108816	Blastmaster® 950 CFM Offshore Aftercooler With Coalescing Tank – 115 Volt Electric
1	10108792	1 Phase Electric Motor Starter - 3 HP to 5 HP
2	1012154	1/4-20 x 1" Hex Bolt Zinc <i>(Four Required)</i>
3	1014017	1/4" Flat Washer Zinc <i>(Eight Required)</i>
4	10101059	3/8-16 x 1-1/4" Bolt Galvanized <i>(Six Required)</i>
5	10101942	3/8" x 3/4" Flat Washer Galvanized <i>(12 Required)</i>
6	10101943	1/2-13 x 1-3/4" Hex Bolt Galvanized <i>(10 Required)</i>
7	10100674	1/2" Flat Washer Galvanized <i>(20 Required)</i>
8	10100675	1/2" Split Lock Washer Galvanized <i>(10 Required)</i>
9	10101941	1/2-13 Hex Nut Galvanized <i>(10 Required)</i>
10	10102589	Offshore Heat Exchanger Mounting Bracket <i>(Two Required)</i>
11	10101036	Heat Exchanger Protective Grate
12	10TTAHP9502	950 CFM Aftercooler Assembly - Complete <i>(See Fig. 8)</i>
13	10101170	Brace
14	10101034	3" NPT Galvanized Pipe Plug
15	—	Inlet Filter Assembly <i>(See Fig. 10)</i>
16	1011902	1-1/4" NPT Galvanized Pipe Plug
17	10101064	1" x 12" NPT Pipe Nipple
18	1011601	1" NPT Full Port Ball Valve
19	1011801	1" NPT Street Elbow
20	20G100737	1/2" NPT Pipe Plug
21	10103303	3/4" Conduit Hub <i>(Two Required)</i>
22	10L805015	3/8" Lock Washer Galvanized <i>(Six Required)</i>
23	10101938	3/8-16 Hex Nut Galvanized <i>(Six Required)</i>
24	10108830	Motor Starter Bracket
25	—	Transfer Hose Assembly <i>(See Fig. 9)</i>
26	20101197	3/4" NPT Cord Grip
27	10103304	3/4" Flexible Conduit
28	1012323	1/4"-20 Lock Nut Zinc <i>(Four Required)</i>
29	1011901	1" Galvanized Pipe Plug
30	1094537	950 CFM Product Sticker
—	10108798	Thermal Unit - Full Load Current 16.2 - 17.6 Amps
—	1091017	Hazard Identification Tag
—	106M078	Part Numbers and Schematics Guide – Blastmaster® 950 CFM Aftercooler with Coalescing Tank
—	1090078	Operator's Manual – Blastmaster® 950 CFM Aftercooler with Coalescing Tank

PART NUMBERS AND SCHEMATICS

Figure 5: Blastmaster® 950 CFM Offshore Aftercooler With Coalescing Tank—115 Volt Electric

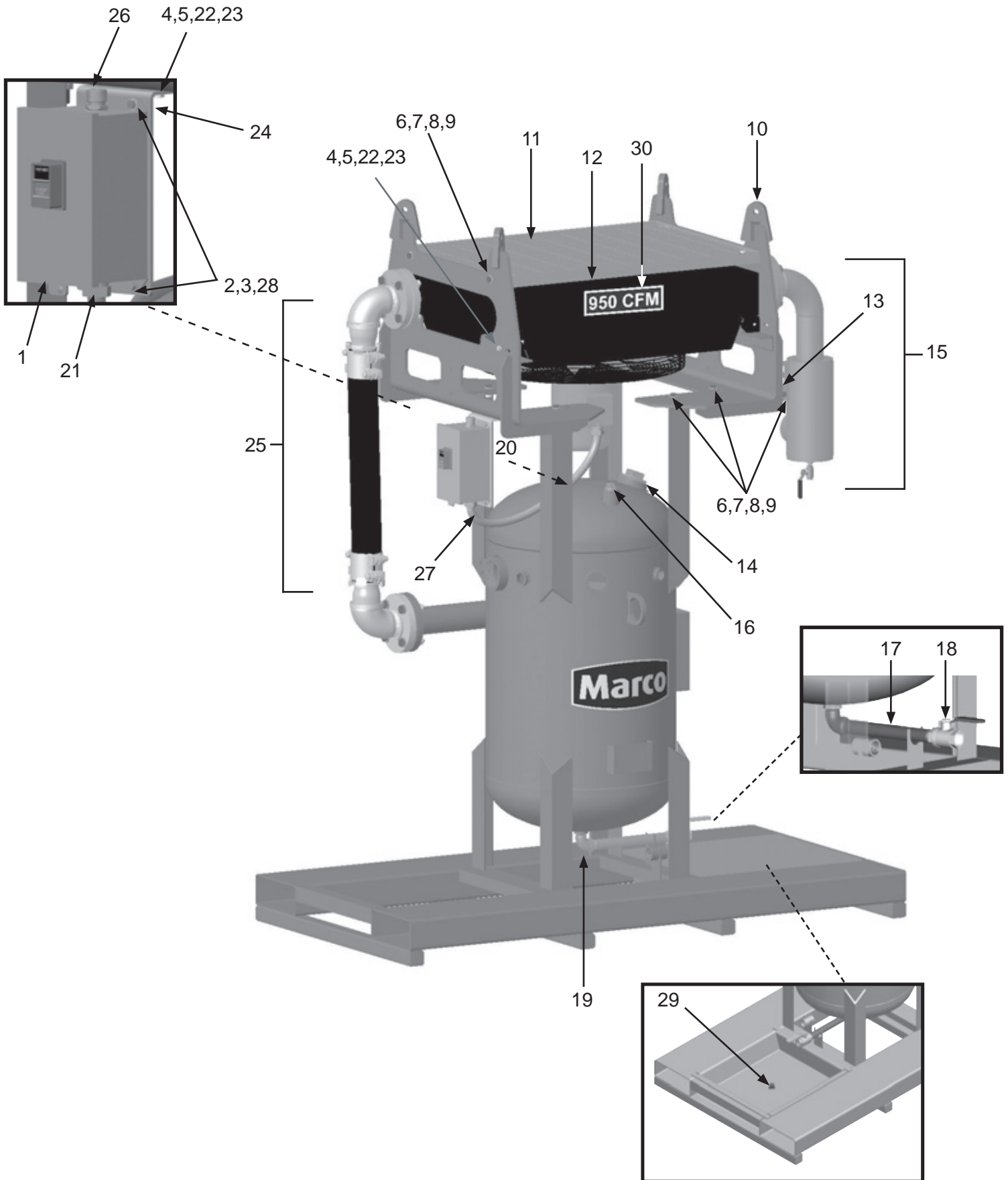

PART NUMBERS AND SCHEMATICS

Blastmaster® 950 CFM Offshore Aftercooler With Coalescing Tank—230 Volt Electric

Item #	Part #	Description
Fig. 6		
—	10102586	Blastmaster® 950 CFM Offshore Aftercooler With Coalescing Tank – 230 Volt Electric
1	10101760	Electric Motor Starter Box – Single Phase
2	1012154	1/4-20 x 1" Hex Bolt Zinc <i>(Four Required)</i>
3	1014017	1/4" Flat Washer Zinc <i>(Eight Required)</i>
4	10101059	3/8-16 x 1-1/4" Bolt Galvanized <i>(Six Required)</i>
5	10101942	3/8" x 3/4" Flat Washer Galvanized <i>(12 Required)</i>
6	10101943	1/2-13 x 1-3/4" Hex Bolt Galvanized <i>(10 Required)</i>
7	10100674	1/2" Flat Washer Galvanized <i>(20 Required)</i>
8	10100675	1/2" Split Lock Washer Galvanized <i>(10 Required)</i>
9	10101941	1/2-13 Hex Nut Galvanized <i>(10 Required)</i>
10	10102589	Offshore Heat Exchanger Mounting Bracket <i>(Two Required)</i>
11	10101036	Heat Exchanger Protective Grate
12	10TTAHP9502	950 CFM Aftercooler Assembly - Complete <i>(See Fig. 8)</i>
13	10101170	Brace
14	10101034	3" NPT Galvanized Pipe Plug
15	—	Inlet Filter Assembly <i>(See Fig. 10)</i>
16	1011902	1-1/4" NPT Galvanized Pipe Plug
17	10101064	1" x 12" NPT Pipe Nipple
18	1011601	1" NPT Full Port Ball Valve
19	1011801	1" NPT Street Elbow
20	20G100737	1/2" NPT Pipe Plug
21	10103303	3/4" Conduit Hub <i>(Two Required)</i>
22	10L805015	3/8" Lock Washer Galvanized <i>(Six Required)</i>
23	10101938	3/8-16 Hex Nut Galvanized <i>(Six Required)</i>
24	10108830	Motor Starter Bracket
25	—	Transfer Hose Assembly <i>(See Fig. 9)</i>
26	20101299	3/4" NPT Cord Grip
27	10103304	3/4" Flexible Conduit
28	1012323	1/4"-20 Lock Nut Zinc <i>(Four Required)</i>
29	1011901	1" Galvanized Pipe Plug
30	1094537	950 CFM Product Sticker
—	10108796	Thermal Unit - Full Load Current 8.48 - 9.83 Amps
—	1091017	Hazard Identification Tag
—	106M078	Part Numbers and Schematics Guide – Blastmaster® 950 CFM Aftercooler with Coalescing Tank
—	1090078	Operator's Manual – Blastmaster® 950 CFM Aftercooler with Coalescing Tank

PART NUMBERS AND SCHEMATICS

Figure 6: Blastmaster® 950 CFM Offshore Aftercooler With Coalescing Tank—230 Volt Electric

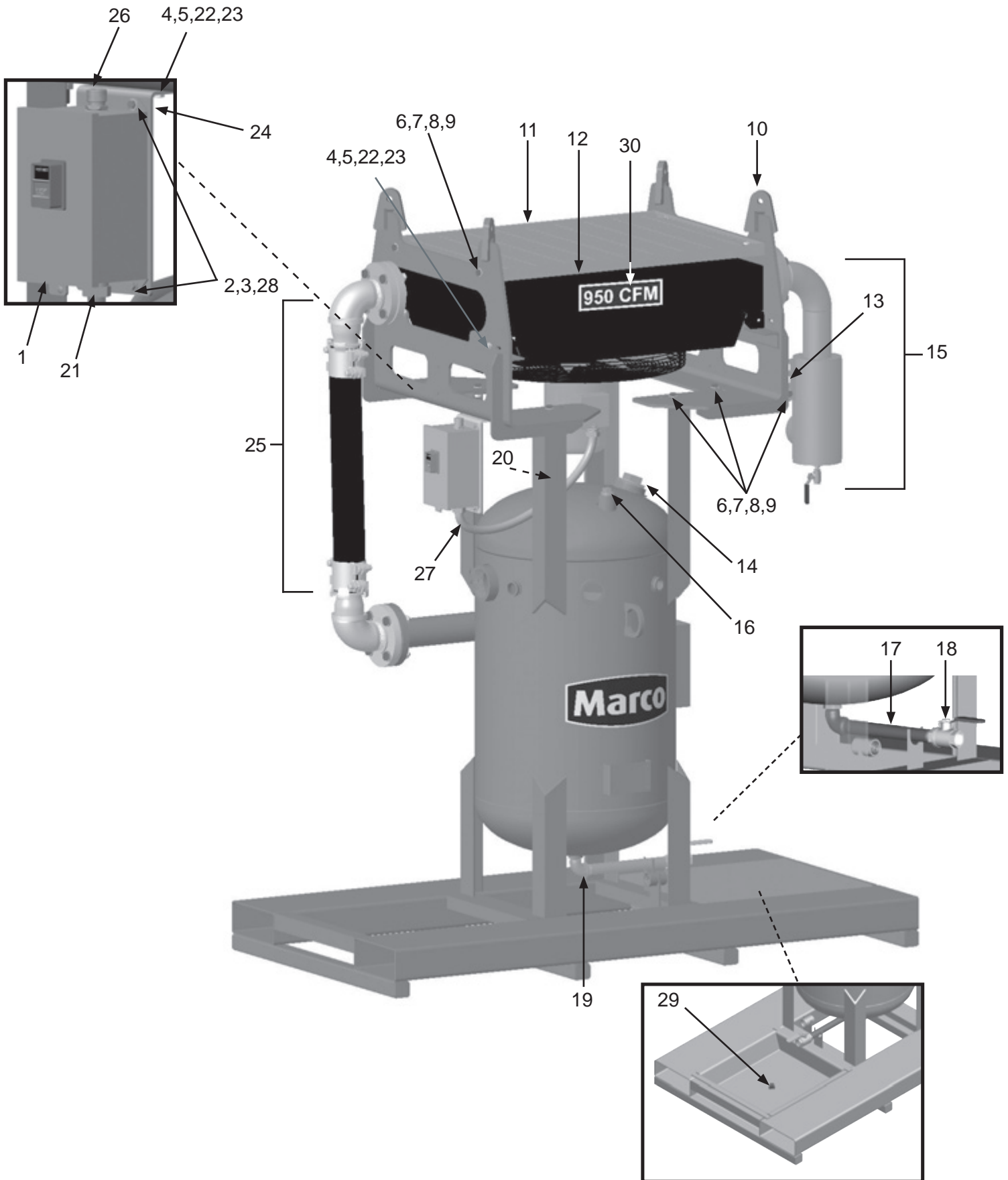

PART NUMBERS AND SCHEMATICS

Figure 7: Aftercooler Assembly—Pneumatic

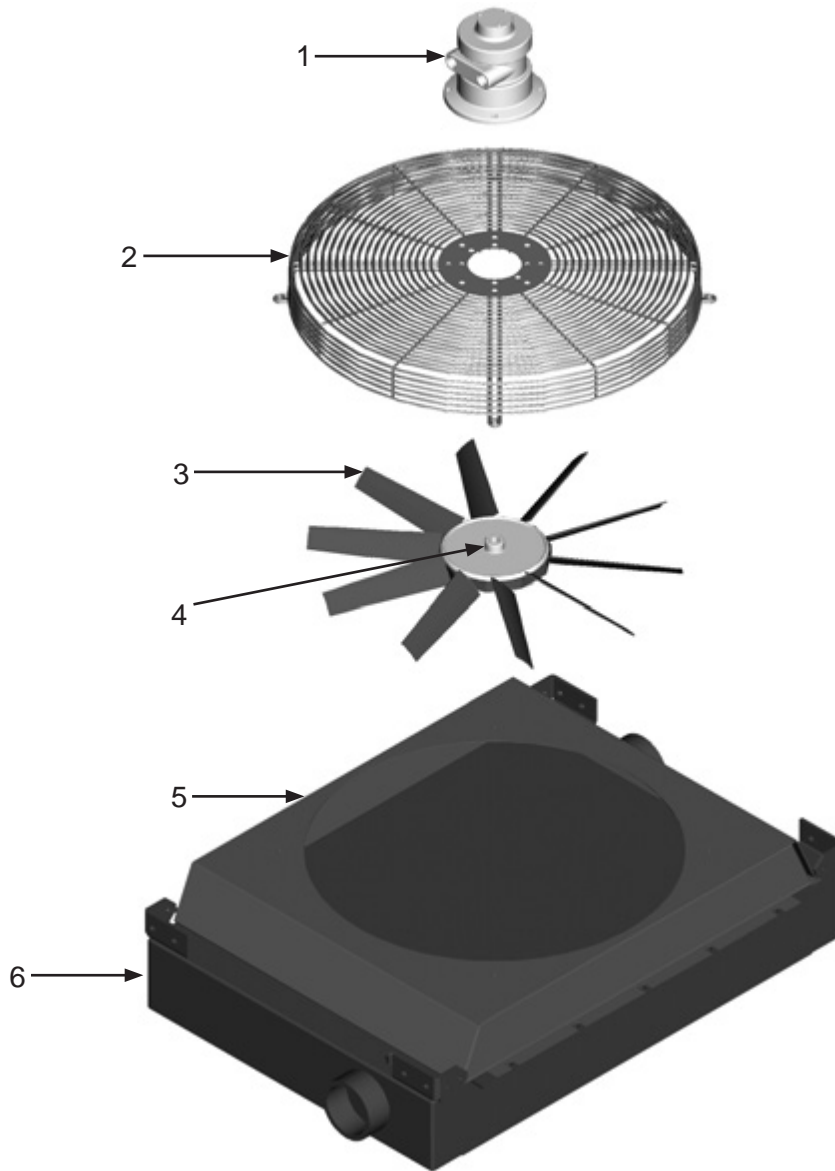

Item #	Part #	Description
Fig. 7		
—	10TTAHP9505	950 CFM Aftercooler—Pneumatic—Complete
1	10101795	Air Motor
2	10101799	Fan Guard
3	10101797	Fan Blades <i>(Includes Blades and Hub)</i>
4	10101798	Fan Bushing
5	10102957	Fan Shroud
6	10101794	Aftercooler Core
—	1070517	Pneumatic Tool Oil - 32 oz.
—	10101796	Air Motor Service Kit <i>(Includes: shaft seal, drive end bearing, dead end bearing, four vanes, four push pins, four vane springs, shim, end cap gasket, muffler cartridge, and muffler felt)</i>

PART NUMBERS AND SCHEMATICS

Figure 8: Aftercooler Assembly—Electric

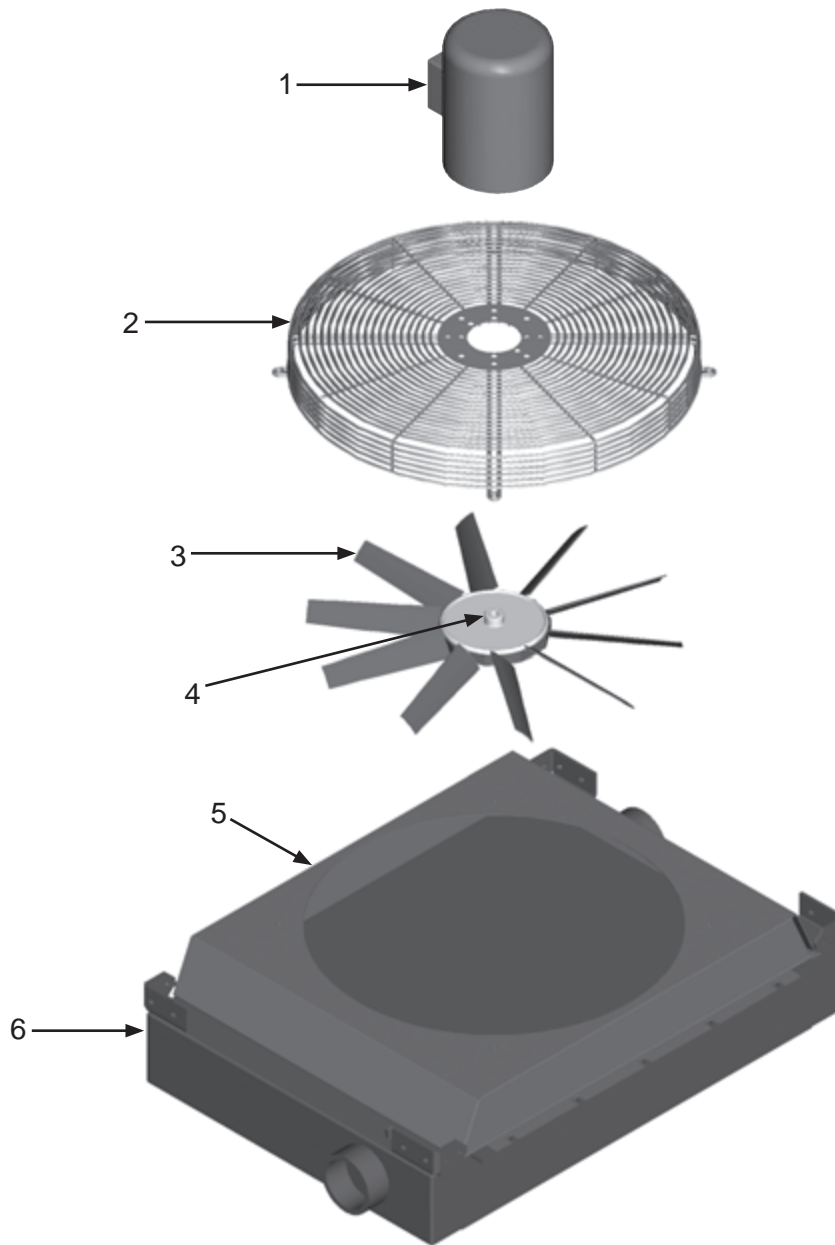

Item #	Part #	Description
Fig. 8		
—	10TTAHP9502	950 CFM Aftercooler—Electric—Complete
1	10101801	Electric Motor – 115/230-Volt AC – Single Phase
2	10101799	Fan Guard
3	10101797	Fan Blades (<i>Includes Blades and Hub</i>)
4	10101802	Fan Bushing
5	10102957	Fan Shroud
6	10101794	Aftercooler Core

PART NUMBERS AND SCHEMATICS

Figure 9: Transfer Hose Assembly

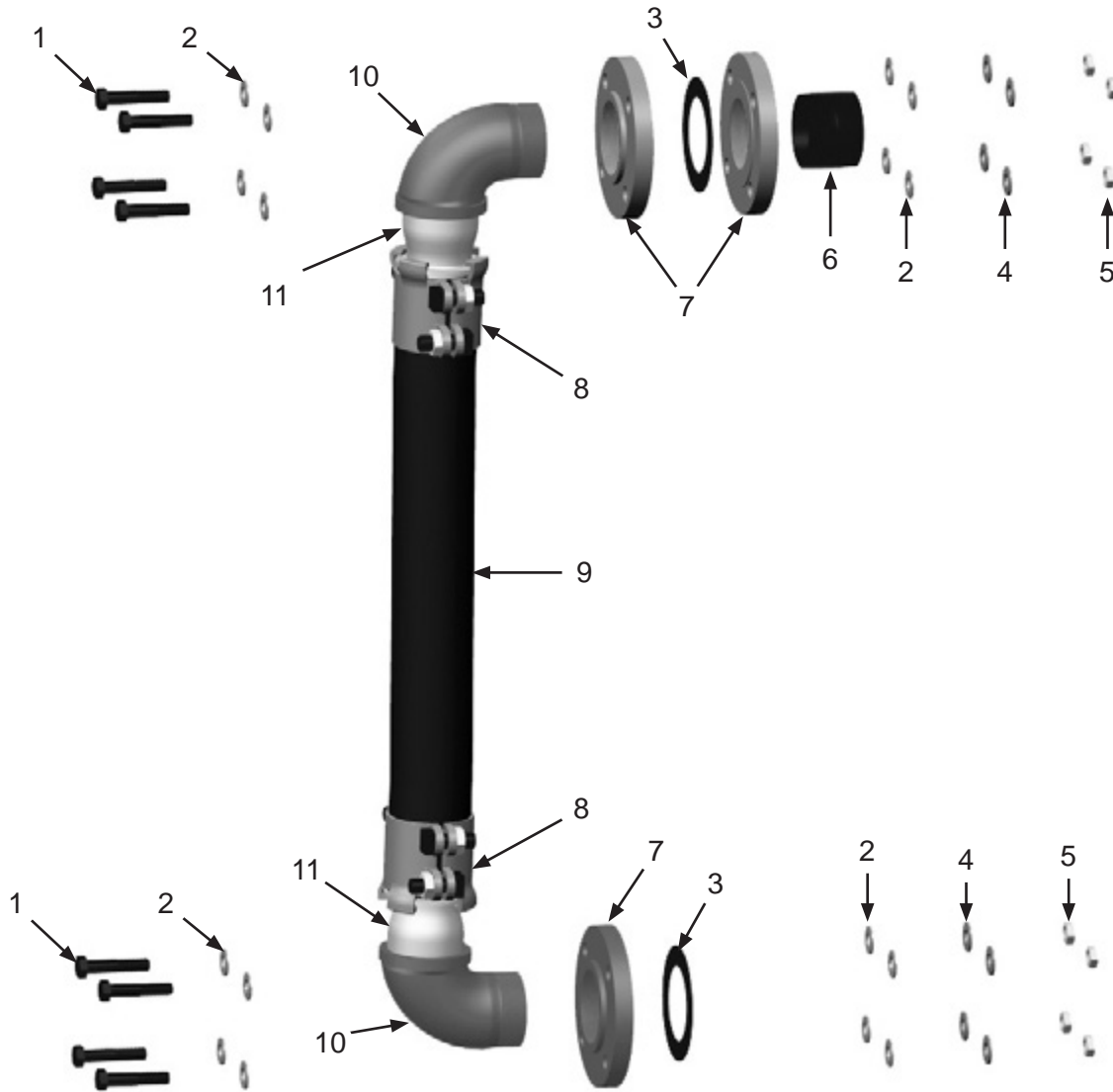

Item #	Part #	Description
--------	--------	-------------

Fig. 9

1	10101058	5/8-11 x 3" Grade 8 Bolt (Eight Required)
2	10101060	5/8" Flat Washer (16 Required)
3	10101047	Flange Gasket (Two Required)
4	10103399	5/8" Grade 8 Split Lock Washer (Eight Required)
5	10103393	5/8-11 Grade 8 Hex Nut (Eight Required)
6	10101040	3" NPT Close Nipple
7	10101041	3" NPT Threaded Flange (Three Required)
8	10BU35	3" Boss Clamp (Two Required)
9	10101045	3" x 2-1/2' Steel Reinforced Air Hose (Per Foot)
10	10101148	3" NPT Street Elbow (Two Required)
11	10101754	3" NPT Hose Stem (Two Required)

PART NUMBERS AND SCHEMATICS

Figure 10: Inlet Filter Assembly

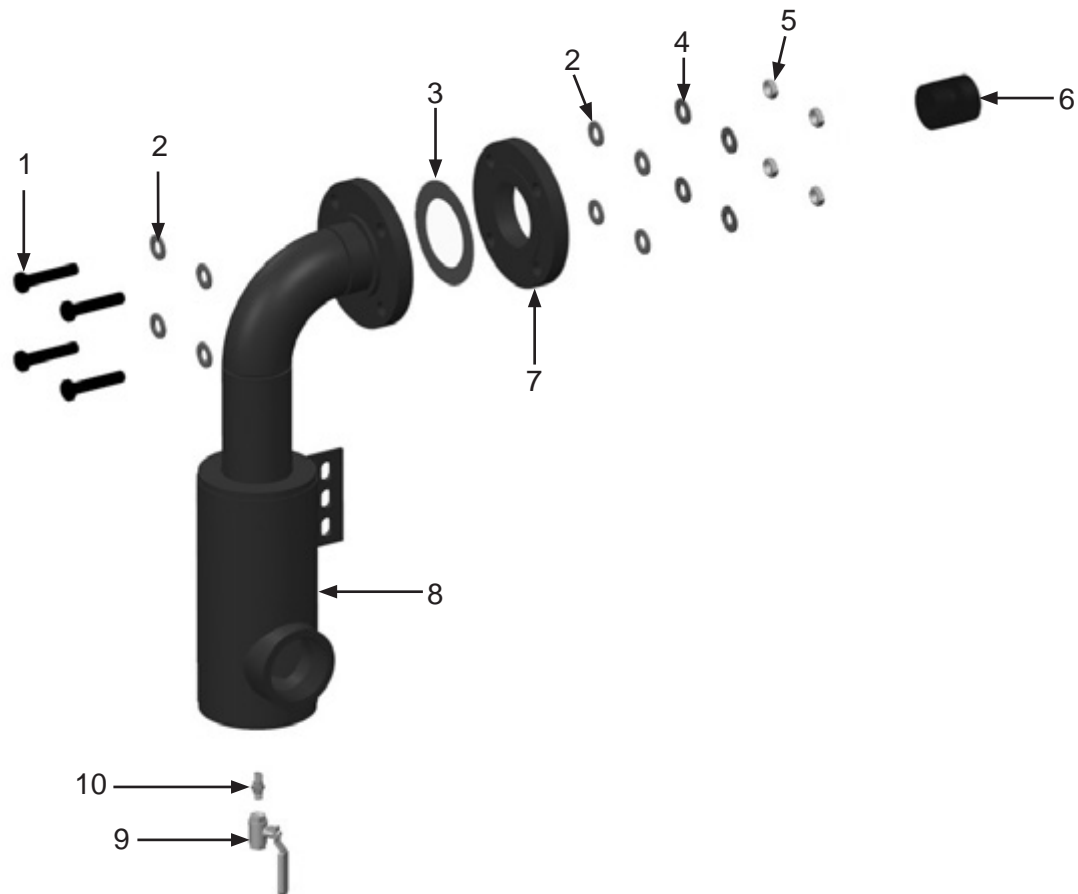

Item #	Part #	Description
--------	--------	-------------

Fig. 10

1	10101058	5/8-11 x 3" Grade 8 Bolt (Four Required)
2	10101060	5/8" Flat Washer (Eight Required)
3	10101047	Flange Gasket
4	10103399	5/8" Grade 8 Split Lock Washer (Four Required)
5	10103393	5/8-11 Grade 8 Hex Nut (Four Required)
6	10101040	3" NPT Close Nipple
7	10101041	3" NPT Threaded Flange
8	10101049	Inlet Filter
9	1080050	1/4" NPT Full Port Ball Valve
10	1017019	1/4" NPT Hex Nipple



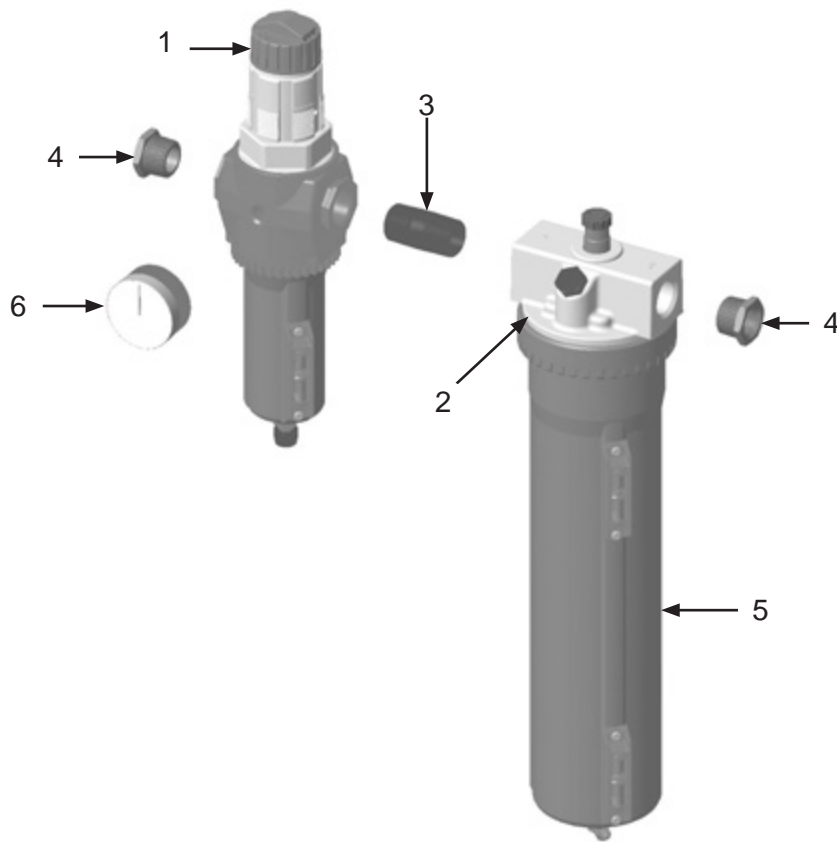

PART NUMBERS AND SCHEMATICS





Figure 11: Air Filter/Regulator/Lubricator







Item #	Part #	Description
Fig. 11		
	10105890	Air Filter/Regulator/Lubricator with Pressure Gauge—Pneumatic—Complete
1	10105891	Filter/Regulator
2	10106432	Large O-ring - Lubricator
3	10105894	3/4" x 2" Pipe Nipple
4	10105895	Coupler with 3/4" x 1/2" Reducing Bushing <i>(Two Required)</i>
5	10106507	Lubricator Bowl
6	1028606	Pressure Gauge – 0-160 PSI 1/4" – Back Mount
—	1070517	Pneumatic Tool Oil - 32 oz.
—	10106504	Diaphragm Kit for Filter/Regulator
—	10106505	Bowl, O-Ring and Site Gauge Kit for Filter/Regulator
—	10106506	Cartridge Kit for Lubricator

OPTIONAL ACCESSORIES

		AIRFLOW SHUTOFF KITS – LUG FITTINGS			
	Part Numbers	Pipe String I.D.	Close Nipple	Full Port Ball Valve	Coupling
	10103731	1"	1012151	1011601	10ME2
	10103732	1-1/4"	1011201 <i>(Quantity of Two)</i>	1011602	10ME3
	10103733	1-1/2"	1014015 <i>(Quantity of Two)</i>	1011603	10ME4
	10103734	2"	1001806 <i>(Quantity of Two)</i>	1011604	10ME5

		AIRFLOW SHUTOFF KITS – HAMMERLOCK FITTINGS			
	Part Numbers	Pipe String I.D.	Close Nipple	Full Port Ball Valve	Coupling Spud
	10103830	1"	10102151 <i>(Quantity of Two)</i>	1011601	10DXGB13
	10103831	1-1/4"	1011201 <i>(Quantity of Two)</i>	1011602	10DXGB18
	10103832	1-1/2"	1014015 <i>(Quantity of Two)</i>	1011603	10DXGB23
	10103833	2"	1001806 <i>(Quantity of Two)</i>	1011604	10DXGB28
	10103934	3"	10101040 <i>(Quantity of Two)</i>	1011608	10GB38

OPTIONAL ACCESSORIES

Part Numbers		GALVANIZED SQUARE HEAD PIPE PLUGS
		Size
	1011901	1"
	1011902	1-1/4"
	1011101	1-1/2"
	1011823	2"
	10101034	3"

Part Numbers	LUBRICATION
1070517	Pneumatic Air Tool Oil - 32 oz. bottle

40+ NATIONWIDE SHIPPING LOCATIONS



CONTACT CENTER

- 3425 East Locust Street
Davenport, IA 52803

ph: 800.BLAST.IT (800.252.7848)
ph: 563.324.2519
fax: 563.324.6258

REGIONAL BRANCH OFFICES

- **Iowa**
Davenport
- **Louisiana**
Gonzales
Lafayette
- **Ohio**
Youngstown
- **Texas**
Beaumont
Corpus Christi
Deer Park

★ Marco Regional Branch Offices
and Shipping Locations

● Direct Shipping Locations



ABRASIVES

BLASTING

COATING

DUST COLLECTORS

ENGINEERED SYSTEMS

RENTAL

SAFETY

SERVICE & REPAIR

VACUUMS

CONTACT MARCO

800.BLAST.IT
(800.252.7848)
563.324.2519
FAX: 563.324.6258

WWW.MARCO.US
SALES@MARCO.US