

OPERATOR'S MANUAL

SPRAYMASTER® 60 GALLON HEATED COATING TANK



BUILT MARCO TOUGH
MARCO MANUFACTURED

⚠ WARNING

Before using this equipment, read, understand and follow all instructions in the Operator's Manuals provided with this equipment. If the user and/or assistants cannot read or understand the warnings and instructions, the employer of the user and/or assistants must provide adequate and necessary training to ensure proper operation and compliance with all safety procedures pertaining to this equipment. If Operator's Manuals have been lost, please visit www.marco.us, or contact Marco at 563.324.2519 for replacements. Failure to comply with the above warning could result in death or serious injury.



Company Profile

Since 1944, Marco has developed a strong tradition of providing innovative and reliable products and services to the surface preparation and protective coatings industries. We are the world's premier provider of Abrasives, Blasting Equipment, Coating and Painting Equipment, Engineered Systems, Rental Equipment, Safety Equipment, Service, and Repair.

Through innovative designs and a total commitment to quality, Marco manufactures products that increase production rates, create a safer workplace, and reduce maintenance costs. Marco's industry experience, manufacturing capabilities, legendary customer service, product availability, logistics services, and technology leadership is your assurance that we deliver high quality products and services, providing the best value to you, our customer.

The Marco Difference

- **Industry Experience** – With Marco on your team, you have access to expertise which can only come from decades of industry leadership. We have organized our engineering department, production specialists, customer operations, and safety support into a “Center of Competence.” As a Marco customer, you have access to hundreds of years of cumulative experience related to your operations.
- **Manufacturing Excellence** – Marco is a U.S. based, ISO 9001:2008 certified manufacturer of equipment for the Surface Preparation and Protective Coatings industries. Marco's engineers benchmark the industry to ensure that we design and manufacture superior products that set the “Gold Standard” for performance, safety, and quality.
- **Legendary Customer Service** – Marco's legendary customer service team is staffed by friendly, highly-trained individuals who are focused on providing the highest level of product support, order accuracy, and customer satisfaction.
- **Product Availability** – We stock over 10,000 SKU's and have over 45 shipping locations to serve North American and International markets for all major brands of blasting and painting equipment. As the largest provider of surface preparation and protective coatings equipment in the world, our inventory levels and product availability are unmatched.
- **Logistics Services** – Marco's in-house logistics team is dedicated to moving your shipment anywhere in the world. We move over 14,000 truckloads every year, allowing you to save on freight costs by leveraging our buying power. Lower your process costs with a single invoice, which includes product and freight.
- **Technology Leadership** – Our website provides: Operator's Manuals, Part Numbers and Schematics Guides, MSDS information, and Features, Advantages, and Benefits Guides, providing access to information 24/7. Our Extranet application allows you to receive quotes and place orders online. Our Intranet maintains a complete record of your purchase history to assist with ongoing support of your existing equipment and future purchasing decisions.

Vision Statement

Marco is the world's premier provider of Abrasives, Blasting Equipment, Coating and Painting Equipment, Engineered Systems, Rental Equipment, Safety Equipment, Service, and Repair.

Mission Statement

Marco provides strong leadership and innovation to the surface preparation and protective coatings industries. We dedicate our efforts to the continuous improvement of our products, services, processes, people, and most importantly, the quality of our customer's experience.

Quality Policy

Marco is committed to providing superior quality in the design, manufacturing, distribution, rental, service, and repair of our products. Our ISO 9001:2008 certification extends throughout all operations in all locations. Continuous improvement of our processes and supply chain Integration comprise the core of our business strategy for delivering exceptional quality and value in all Marco products and services.

Management Philosophy

We are a company dedicated to the success of every customer and associate. We discuss, debate, challenge, measure, and test our ideas. We will be boundless and limitless in our passion to improve. Through sound leadership and dedicated associates, we will ensure a long term, profitable future for Marco, our associates, customers, and suppliers.

TABLE OF CONTENTS

Company Profile	1	Fill Antifreeze	16
Definition of Terms	2	Hazard Identification Decals	17
Hazard Identifications	3	Troubleshooting	18
Air & Abrasive Consumption Chart	6	Spraymaster® 60 Gallon Heated Coatings Tank Specifications	19
Daily Pre-Operation Checklist	8	Assembly Part Numbers and Schematics	21
Operating Instructions	9	Spraymaster® 60 Gallon Heated Coatings Tank 240/480-Volt AC Intrinsically Safe	21
Description	9	Spraymaster® 60 Gallon Heated Coatings Tank 240/480-Volt AC Intrinsically Safe with 5:1 Transfer Pump	23
Operational Requirements	9	Spraymaster® 60 Gallon Heated Coatings Tank 240/480-Volt AC Intrinsically Safe with 10:1 Transfer Pump	24
Initial Setup	9	Wye Strainer	25
Operating Instructions	9	Limited Warranty	26
Maintenance	11	Disclaimer of Warranty	26
Remove and Install Transfer Pump (If Equipped).	11	Exclusive Remedy for Warranty Claims	26
Remove and Install Wye Strainer	11	Limitation of Remedies	26
Remove and Install Tank Heater	12		
Fill Coating Tank	12		
Remove and Install Agitator Assembly	13		
Remove and Install Tank Lid	14		
Clean Inside of Coating Tank	15		

DEFINITION OF TERMS

DANGER

This is an example of danger. This indicates an imminently hazardous situation which, if not avoided, will result in death or serious injury.

CAUTION

This is an example of a caution. This indicates a potentially hazardous situation which, if not avoided, may result in minor or moderate injury. It can also be used to alert against unsafe practices.

WARNING

This is an example of a warning. This indicates a potentially hazardous situation which, if not avoided, could result in death or serious injury.

NOTICE

This is an example of a notice. This indicates policy or practice directly related to safety of personnel or protection of property.

HAZARD IDENTIFICATIONS

⚠ WARNING

Failure to comply with ANY WARNING listed below could result in death or serious injury.

- ▶ OSHA sets exposure limits to protect workers from exposure to respirable crystalline silica, 29 CFR 1910.1053. Airborne dust could increase the exposure levels beyond permissible limits. Breathing dust containing silica could cause silicosis, a fatal lung disease. Breathing dust during abrasive blasting operations, post-blast cleaning operations, and/or servicing equipment within the abrasive blasting area may expose an individual to conditions that could cause asbestosis, lead poisoning and/or other serious or fatal diseases. Harmful dust containing toxic material from abrasives or surfaces being abrasive blasted can remain suspended in the air for long periods of time after abrasive blasting has ceased. A NIOSH-approved, well-maintained, respirator designed for the specific operation being performed must be used by anyone abrasive blasting, handling or using the abrasive, and anyone in the area of the dust.
- ▶ Contact NIOSH and OSHA offices to determine the proper respirator for your specific application. The air supplied to the respirator must be at least Grade D quality as described in Compressed Gas Association Commodity Specification G-7.1 and as specified by OSHA Regulation 1910.134. Ensure air filter and respirator system hoses are not connected to non-air sources or in-plant lines that may contain nitrogen, oxygen, acetylene or other non-breathable gases. Before removing respirator, use an air monitoring instrument to determine if the atmosphere is safe to breathe.
- ▶ You must comply with all OSHA, local, City, State, Province, Country and jurisdiction regulations, ordinances and standards, related to your particular work area and environment. Keep unprotected individuals out of the work area.
- ▶ Abrasive blasting operators must receive thorough training on the use of abrasive resistant attire which includes: supplied-air respirator, abrasive blasting suit, safety shoes, gloves, ear protection and eye protection. Protect the operator and bystanders by complying with NIOSH and OSHA Safety Standards.
- ▶ Inspect all equipment for wear or damage before and after each use. Failure to use Original Equipment Manufacturer repair parts and failure to immediately replace worn or damaged components could void warranties and cause malfunctions.
- ▶ OSHA requires abrasive blasting nozzles be equipped with an operating valve, which shall be designed to be held open only by continuous hand pressure and shall close immediately upon release of hand pressure (i.e., a “deadman” control). The valve shall not be modified in any manner that would allow it to remain open without the application of continuous hand pressure by the operator. Failure to comply with the above warning could result in release of high speed abrasive and compressed air resulting in death or serious injury. OSHA 29CFR 1910.244(b)
- ▶ Point the abrasive blasting nozzle only at the surface being abrasive blasted. Never point the abrasive blasting nozzle or abrasive stream at yourself or others.
- ▶ Unless otherwise specified, maximum working pressure of abrasive blasting pots and related components must not exceed 150 psi. Exceeding maximum working pressure of 150 psi could cause the abrasive blasting pot and components to burst. Failure to comply with the above warning could result in death or serious injury.
- ▶ Never weld, grind or drill on the abrasive blasting pot (or any pressure vessel). Doing so will void ASME certification and manufacturer’s warranty. Welding, grinding or drilling on the abrasive blasting pot (or any pressure vessel) could weaken the vessel causing it to burst. Failure to comply with the above warning could result in death or serious injury. (ASME Pressure Vessel Code, Section VIII, Division 1)
- ▶ This equipment is not intended for use in any area that might be considered a hazardous location, as described in the National Electric Code NFPA 70, Article 500. Use of this equipment in a hazardous location could cause an explosion or electrocution.
- ▶ Never attempt to move an abrasive blasting pot containing abrasive. Never attempt to manually move abrasive blasting pots greater than 6.5 cubic foot capacity. Always use at least two capable people to manually move an abrasive blasting pot on flat, smooth surfaces. A mechanical lifting device must be used if an abrasive blasting pot is moved in any other manner.

HAZARD IDENTIFICATIONS

WARNING

Failure to comply with ANY WARNING listed below could result in death or serious injury.

- ▶ This product is not for use in wet environments. Always use a Ground Fault Interrupter Circuit (GFI) for all electrical power source connections. Use of this product in wet environments could create a shock or electrocution hazard.
- ▶ Frozen moisture could cause restrictions and obstructions in pneumatic control lines. Any restriction or obstruction in the pneumatic control lines could prevent the proper activation and deactivation of the remote control system, resulting in the release of high speed abrasive and compressed air. In conditions where moisture may freeze in the control lines an antifreeze injection system approved for this application can be installed.
- ▶ Do not cut, obstruct, restrict or pinch pneumatic control lines. Doing so could prevent the proper activation and deactivation of the remote control system, resulting in the release of high speed abrasive and compressed air.
- ▶ Use of Marco remote control switches with other manufacturer's remote control systems could cause unintended activation of remote control systems resulting in the release of high speed abrasive and compressed air. Only Marco remote control switches should be used with Marco remote control systems.
- ▶ Always be certain to have secure footing when abrasive blasting. There is a recoil hazard when abrasive blasting starts that may cause user to fall and misdirect the abrasive stream at operator or bystander.
- ▶ Never use an abrasive blasting pot or attachments as a climbing device. The person could slip and fall. The abrasive blasting pot could become unstable and tip over.
- ▶ For equipment manufactured by entities other than Marco, you must consult the Original Equipment Manufacturer operator's manuals, information, training, instructions and warnings, for the proper and intended use of all equipment.
- ▶ Flammable fumes, such as solvent and paint fumes in the work area can present an ignition or explosion hazard if allowed to collect in adequate concentrations. To reduce conditions that could result in a fire or an explosion, provide adequate ventilation, eliminate all ignition or spark sources, keep the work area free of debris, store solvents and solvent contaminated rags in approved containers, follow proper grounding procedures, do not plug/unplug power cord or turn on/off power switches when flammable fumes are present, keep a working fire extinguisher or provide another fire suppression system in the work area. Cease all operations and correct condition if a spark or ignition source is identified during operation.
- ▶ Always depressurize the entire system, disconnect all power sources and lockout/tagout all components before any maintenance or troubleshooting is attempted. Failure to comply with the above warning could cause electrical shock and inadvertent activation of equipment resulting in death or serious injury.
- ▶ Moving parts can present an area where crushing, pinching, entanglement or amputation may occur. Do not place body parts or foreign objects in any area where there are moving parts.
- ▶ Surfaces of heated supply tanks, drums and/or lines as well as the adjoining plumbing may become hot during normal use. Do not touch these heated surfaces without proper protection. Deactivate and allow sufficient time for all surfaces to cool before attempting any maintenance.
- ▶ High-pressure fluid from gun, hose leaks, or ruptured components can pierce skin and can cause a serious injury that may result in amputation. Do not point gun or spray tip at anyone or at any part of the body. Keep clear of any leaks or ruptures. Depressurize the entire system before attempting cleaning, inspecting, or servicing equipment.
- ▶ Exposure to toxic fluids or fumes may occur during the normal operation of this system. Before attempting to fill, use, or service this system, read SDS's to know the specific hazards of the fluids you are using. Always use proper Personal Protective Equipment when attempting to fill, use, or service this system.
- ▶ The use of this product for any purpose other than originally intended or altered from its original design is prohibited.
- ▶ Never hang objects from the abrasive blasting pot handle. Doing so may cause the abrasive blasting pot to become unstable and tip over.

HAZARD IDENTIFICATIONS

⚠ CAUTION

Failure to comply with ANY CAUTION listed below may result in minor or moderate injury.

- ▶ Static electricity can be generated by abrasive moving through the abrasive blasting hose causing a shock hazard. Prior to use, ground the abrasive blasting pot and abrasive blasting nozzle to dissipate static electricity.
- ▶ High decibel noise levels are generated during the abrasive blasting process which may cause loss of hearing. Ensure appropriate Personal Protective Equipment and hearing protection is in use.

NOTICE

Failure to comply with ANY NOTICE listed below could pose a hazard to personnel or property.

- ▶ See Air & Abrasive Consumption Chart for estimated abrasive consumption rates and required air flow (cubic feet per minute). Your system must meet these minimum requirements to ensure proper function and performance.
- ▶ Always use abrasive that is dry and properly screened. This will reduce the potential for obstructions to enter the remote control system, abrasive metering valve and abrasive blasting nozzle.
- ▶ Moisture build-up occurs when air is compressed. Any moisture within the abrasive blasting system will cause abrasive to clump, clogging metering valves, hoses and nozzles. Install an appropriately sized moisture separator at the inlet of the abrasive blasting system. Leave the moisture separator petcock slightly open to allow for constant release of water. If insufficient volume of air exists and petcock is unable to be left open (at all times) petcock should be opened frequently to release water.
- ▶ To reduce abrasive intrusion in the air supply hose, depressurize the abrasive blasting pot before shutting off air supply from compressor.
- ▶ Inspect abrasive blasting nozzle before placing into service. Damage to abrasive blasting nozzle liner or jacket may occur during shipping. If you receive a damaged abrasive blasting nozzle, contact your distributor immediately for replacement. Abrasive blasting nozzles placed into service may not be returned. Abrasive blasting nozzle liners are made of fragile materials and can be damaged by rough handling and striking against hard surfaces. Never use a damaged abrasive blasting nozzle.
- ▶ Abrasive blasting at optimal pressure for the abrasive used is critical to productivity. Example: For an abrasive with an optimal abrasive blasting pressure of 100 psi at the abrasive blasting nozzle, one pound per square inch of pressure loss will reduce abrasive blasting efficiency by 1.5%. A 10 psi reduction in air pressure will cause a 15% loss of efficiency. Use a Needle Pressure Gauge to identify pressure drops in your system. Consult with your abrasive supplier for the requirements of your abrasive.
- ▶ Replace abrasive blasting nozzle if liner or jacket is cracked or damaged. Replace abrasive blasting nozzle if original orifice size has worn 1/16" or more. Determine abrasive blasting nozzle wear by inserting a drill bit 1/16" larger than original size of abrasive blasting nozzle orifice. If the drill bit passes through abrasive blasting nozzle, replacement is needed.

AIR & ABRASIVE CONSUMPTION CHART

NOTICE

Failure to comply with ANY NOTICE listed below could pose a hazard to personnel or property.

- ▶ See Air & Abrasive Consumption Chart for estimated abrasive consumption rates and required air flow (cubic feet per minute). Your system must meet these minimum requirements to ensure proper function and performance.
- ▶ When it comes to air & abrasive mixtures, more is not necessarily better. Optimum abrasive blasting efficiency takes place when a lean air & abrasive mixture is used. To correctly set the abrasive metering valve, begin with the valve fully closed and slowly increase the amount of abrasive entering the airstream. As you increase the abrasive flow, watch for a “blue flame” at the exit of the abrasive blasting nozzle. Faster cutting, reduced abrasive consumption and lower clean up costs, are benefits of the “blue flame”.
- ▶ Abrasive blasting at optimal pressure for the abrasive used is critical to productivity. Example: For an abrasive with an optimal abrasive blasting pressure of 100 psi at the abrasive blasting nozzle, one pound per square inch of pressure loss will reduce abrasive blasting efficiency by 1.5%. A 10 psi reduction in air pressure will cause a 15% loss of efficiency. Use a Needle Pressure Gauge to identify pressure drops in your system. Consult with your abrasive supplier for the requirements of your abrasive.

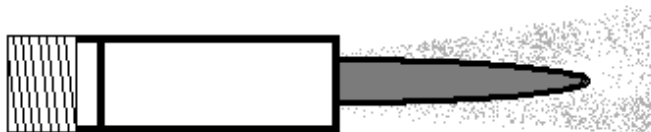

“Blue Flame”

NOTICE

Inspect abrasive blasting nozzle before placing into service. Damage to abrasive blasting nozzle liner or jacket may occur during shipping. If you receive a damaged abrasive blasting nozzle, contact your distributor immediately for replacement. Abrasive blasting nozzles placed into service may not be returned. Abrasive blasting nozzle liners are made of fragile materials and can be damaged by rough handling and striking against hard surfaces. Never use a damaged abrasive blasting nozzle.

Air & Abrasive Consumption Chart*

Nozzle Orifice	Pressure at the Nozzle (PSI)								Air (in cfm), Abrasive & Compressor Requirements
	50	60	70	80	90	100	125	140	
No. 2 (1/8")	11 67 2.5	13 77 3	15 88 3.5	17 101 4	18 112 4.5	20 123 5	25 152 5.5	28 170 6.2	Air (cfm) Abrasive (lbs/hr) Compressor Horsepower
No. 3 (3/16")	26 150 6	30 171 7	33 196 8	38 216 9	41 238 10	45 264 10	55 319 12	62 357 13	Air (cfm) Abrasive (lbs/hr) Compressor Horsepower
No. 4 (1/4")	47 268 11	54 312 12	61 354 14	68 408 16	74 448 17	81 494 18	98 608 22	110 681 25	Air (cfm) Abrasive (lbs/hr) Compressor Horsepower
No. 5 (5/16")	77 468 18	89 534 20	101 604 23	113 672 26	126 740 28	137 812 31	168 982 37	188 1100 41	Air (cfm) Abrasive (lbs/hr) Compressor Horsepower
No. 6 (3/8")	108 668 24	126 764 28	143 864 32	161 960 36	173 1052 39	196 1152 44	237 1393 52	265 1560 58	Air (cfm) Abrasive (lbs/hr) Compressor Horsepower
No. 7 (7/16")	147 896 33	170 1032 38	194 1176 44	217 1312 49	240 1448 54	254 1584 57	314 1931 69	352 2163 77	Air (cfm) Abrasive (lbs/hr) Compressor Horsepower
No. 8 (1/2")	195 1160 44	224 1336 50	252 1512 56	280 1680 63	309 1856 69	338 2024 75	409 2459 90	458 2754 101	Air (cfm) Abrasive (lbs/hr) Compressor Horsepower
No. 10 (5/8")	308 1875 68.5	356 2140 79.5	404 2422 90	452 2690 100.5	504 2973 112	548 3250 122	663 3932 146	742 4405 165	Air (cfm) Abrasive (lbs/hr) Compressor Horsepower
No. 12 (3/4")	432 2672 96	504 3056 112	572 3456 127	644 3840 143	692 4208 154	784 4608 174.5	948 5570 209	1062 6238 236	Air (cfm) Abrasive (lbs/hr) Compressor Horsepower

*Abrasive consumption is based on abrasive with a bulk density of 100 lbs per Cubic Foot

NOTICE

Replace abrasive blasting nozzle if liner or jacket is cracked or damaged. Replace abrasive blasting nozzle if original orifice size has worn 1/16" or more. Determine abrasive blasting nozzle wear by inserting a drill bit 1/16" larger than original size of abrasive blasting nozzle orifice. If the drill bit passes through abrasive blasting nozzle, replacement is needed.

“THE BIG PICTURE”

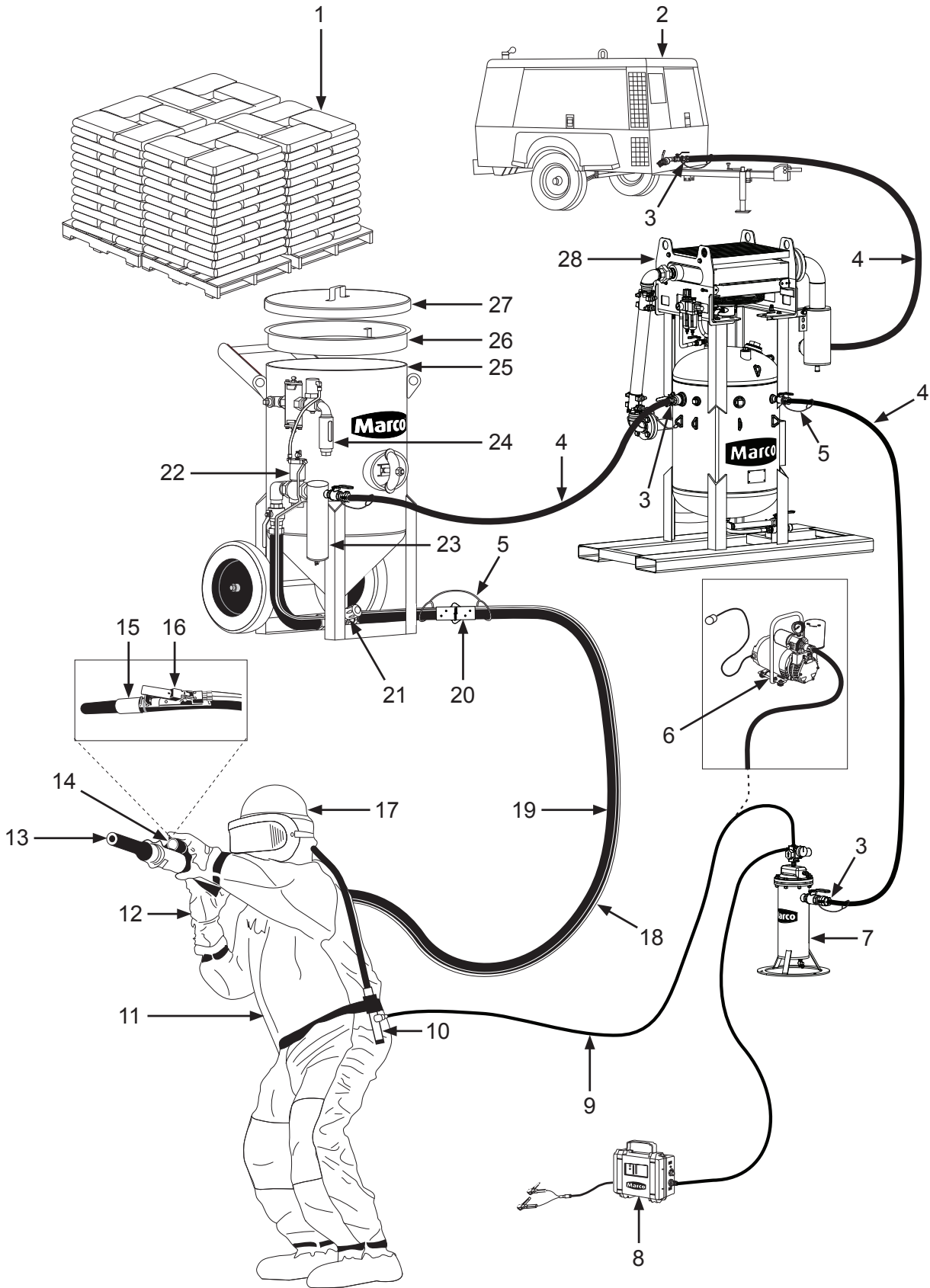

DAILY PRE-OPERATION CHECKLIST

Daily Pre-operation Checklist

- 1. Abrasive
- 2. Air Compressor
- 3. Air Hose Couplings & Gaskets
- 4. Air Hose
- 5. Safety Cable
- 6. Ambient Air Pump*
- 7. Breathing Air Filter
- 8. CO Monitor
- 9. Breathing Line
- 10. Climate Control Device
- 11. Abrasive Blasting Suit
- 12. Gloves
- 13. Abrasive Blasting Nozzle
- 14. Lighting System*
- 15. Abrasive Blasting Nozzle Holder
- 16. Remote Control Switch
- 17. Supplied-Air Respirator
- 18. Control Line
- 19. Abrasive Blasting Hose
- 20. Abrasive Blasting Hose Couplings & Gaskets
- 21. Abrasive Metering Valve
- 22. Remote Control System
- 23. Moisture Separator
- 24. Abrasive Blasting Pot Exhaust Muffler
- 25. Abrasive Blasting Pot
- 26. Abrasive Blasting Pot Screen
- 27. Abrasive Blasting Pot Lid
- 28. Aftercooler*

* *Optional or alternative device.
Ask your Marco Representative
for more details.*

Abrasive – Select the correct Abrasive (1) for the application. Review the SDS (*Safety Data Sheet*) to ensure the correct PPE (*Personal Protective Equipment*) and Environmental Controls have been selected and are in place.

Air Compressor – Select an Air Compressor (2) of adequate size to support all equipment requirements. Refer to “Air & Abrasive Consumption Chart” for Abrasive Blasting Nozzle (13) air consumption requirements. Before connecting Air Hose (4), sample the air being produced by the air compressor (2) to ensure it is free of petroleum contaminants.

Air Hose, and Air Hose Couplings & Gaskets – Select Air Hoses (4) of sufficient size to support all subsequent volumetric requirements and with a sufficient PSI (*pound per square inch*) rating. Inspect all Air Hoses (4), and Air Hose Couplings & Gaskets (3) for damage or wear. Repair or replace damaged or worn components.

Abrasive Blasting Hose, Abrasive Blasting Hose Couplings & Gaskets, and Abrasive Blasting Nozzle Holder – Select an Abrasive Blasting Hose (19) that has an inner diameter 3 to 4 times larger than your Abrasive Blasting Nozzle (13). Inspect Abrasive Blasting Hose (19), Abrasive Blasting Hose Couplings & Gaskets (20), and Abrasive Blasting Nozzle Holder (15) for damage or wear. Repair or replace damaged or worn components.

Safety Cables – Install a Safety Cable (5) at each Abrasive Blasting Hose (19), and Air Hose (4) connection points.

Aftercooler and Moisture Separator – Ensure Aftercooler (28) is positioned on stable ground. Keep petcock drain of Moisture Separator (23) slightly open during use. Drain both devices after each use.

Supplied-Air Respirator, Breathing Line, Breathing Air Filter, Climate Control Device, CO Monitor, Ambient Air Pump – You MUST consult the Operator’s Manual supplied with your Respiratory Equipment (6, 7, 8, 9, 10, 17) for ALL applicable instructions and warnings. Inspect all Respiratory Equipment components for damage or wear. Repair or replace damaged or worn components.

Abrasive Blasting Suit and Gloves – Select an abrasive-resistant Abrasive Blasting Suit (11) that is slightly oversized to allow ease of movement and allows air to flow around your body. Select abrasive-resistant Gloves (12) with a tight fit and a long cuff that overlaps the sleeve of the Abrasive Blasting Suit (11).

Abrasive Metering Valve and Abrasive Blasting Pot – Confirm Abrasive Blasting Pot (25) is positioned on stable ground. Inspect Abrasive Blasting Pot (25) and Abrasive Metering Valve (21) for damage or wear. Repair or replace damaged or worn components.

Abrasive Blasting Pot Screen and Abrasive Blasting Pot Lid – Always use an Abrasive Blasting Pot Screen (26) when filling Abrasive Blasting Pot (25) with Abrasive (1) to prevent debris from entering the Abrasive Blasting Pot (25). Remove Abrasive Blasting Pot Lid (27) before operating the Abrasive Blasting Pot (25). Install Abrasive Blasting Pot Lid (27) after use to protect the Abrasive Blasting Pot’s (25) interior.

Remote Control System, Remote Control Switch, Control Line, – Inspect Remote Control System (22) and Control Line (18) for damage or wear. Repair or replace damaged or worn components. Ensure Control Line (18) fittings connected to the Remote Control System (22) are tight and free of leaks. Ensure Remote Control Switch (16) is functioning properly. Consult Remote Control Switch Operator’s Manual for applicable instructions.

Abrasive Blasting Pot Exhaust Muffler – Inspect Abrasive Blasting Pot Exhaust Muffler (24) at start and end of daily use. Replace element of Abrasive Blasting Pot Exhaust Muffler (24) per Operator’s Manual instructions.

Lighting System – Ensure the Lighting System (14) is connected to a proper power supply before use.

OPERATING INSTRUCTIONS

WARNING

W-594

Read, understand, and follow the Original Equipment Manufacturer operator's manuals, information, training, instructions, and warnings, for the proper and intended use of all equipment. Failure to comply with the above warning could result in death or serious injury.

WARNING

W-505

Inspect all equipment for wear or damage before and after each use. Failure to use Original Equipment Manufacturer repair parts and failure to immediately replace worn or damaged components could void warranties and cause malfunctions. Failure to comply with the above warning could result in death or serious injury.

WARNING

W-556

All electrical connections are to be made by a qualified electrician in accordance with all applicable codes, ordinances and good practices. Failure to comply with the above warning could result in death or serious injury.

WARNING

W-520

The use of this product for any purpose other than originally intended or altered from its original design is prohibited. Failure to comply with the above warning could result in death or serious injury.

Description

Heated coatings tanks can be used as a stand-alone tank or as an integrated part of a plural component spray system. The Spraymaster® 60 Gallon Heated Coatings Tank is a vessel used to hold, heat, and blend a coating material. An electric immersion heater maintains a consistent temperature of a liquid solution that transfers heat to the coating material in the tank. This transfer of heat reduces the viscosity of the material allowing for improved blending by a pneumatically driven agitator. The round tank design allows for even mixing and heating of the coating. Typical applications include paint booths, paint yards, bridges, oil refineries, pipelines, railcar shops, and storage tanks.

Operational Requirements

- 240-Volt AC/20 amp or 480-Volt AC/20 amp as required.
- 60 CFM @ 50-150 psi filtered and regulated compressed air with out optional Transfer Pump (1).
- 120 CFM @ 50-150 psi filtered and regulated compressed air with optional Transfer Pump (1).

The following may cause safety hazards or reduced performance:

- Hose connections and piping connections are not tight and free of leaks.
- Insufficient compressed air supply pressure and/or volume (120 CFM and 50-150 psi).
- Improper electric voltage and/or amperage (240-Volt AC/20 amp or 480-Volt AC/20 amp).

Initial Setup

- Have a qualified electrician connect to power supply.
- Properly ground unit using Ground Lug (9).
- Connect filtered and regulated compressed air supply to Agitator Assembly (3).
- Refer to existing equipment Manufacturer's Operator's Manuals for guidance when connecting to Spraymaster® 60 Gallon Heated Coatings Tank.

Operating Instructions

Operating Instructions are limited to the instructions found in the Original Equipment Manufacturer's Operator's Manuals. Please refer to all literature included with your Spraymaster® 60 Gallon Heated Coatings Tank at time of delivery. If this literature is unavailable, please contact your Marco representative for a replacement set before use.

Before use:

- Inspect entire system for fluid leaks, air leaks or damage. Repair or replace damaged components.
 - Transfer Pump (1)
 - Needle Valve (4)
 - Tank Heater (7)
 - Wye Strainer (2)
 - Coating Tank (5)
 - Ball Valve (8)
 - Agitator Assembly (3)
 - Thermometer (6)
 - Ground Lug (9)
- Check Antifreeze level. See Fill Antifreeze.
- Ensure sufficient compressed air supply volume and pressure (120 CFM @ 50-150 psi).

OPERATING INSTRUCTIONS

WARNING

Flammable fumes, such as solvent and paint fumes in the work area can present an ignition or explosion hazard if allowed to collect in adequate concentrations. To reduce conditions that could result in a fire or an explosion, provide adequate ventilation, eliminate all ignition or spark sources, keep the work area free of debris, store solvents and solvent contaminated rags in approved containers, follow proper grounding procedures, do not plug/unplug power cord or turn on/off power switches when flammable fumes are present, keep a working fire extinguisher or provide another fire suppression system in the work area. Cease all operations and correct condition if a spark or ignition source is identified during operation. Failure to comply with the above warning could result in death or serious injury.

WARNING

Exposure to toxic fluids or fumes may occur during the normal operation of this system. Before attempting to fill, use, or service this system, read SDS's to know the specific hazards of the fluids you are using. Always use proper Personal Protective Equipment when attempting to fill, use, or service this system. Failure to comply with the above warning could result in death or serious injury.

Start Up:

- Add coating to tank. See Fill Coating Tank.
- Adjust Heater (7) to recommended temperature. See original equipment manufacturer's Operator's Manual and coating technical data sheet.

Note: Agitator speed should be set only high enough to create motion. Too fast, and the agitator could create bubbles.

- Adjust speed of agitator motor by turning Needle Valve (4).
- Once coating is at proper temperature and viscosity, supply compressed air to Transfer Pump (1). See transfer pump Operator's Manual.

During use:

- Monitor fluid temperature at Tank Thermometer (6). See technical data sheet for product being stored in coating tank.
- Monitor air pressure to agitator motor and Transfer Pump (1).
- Monitor speed of agitator motor and adjust as needed by turning Needle Valve (4).

Shut down:

- Shut off air to agitator motor and Transfer Pump (1). See original equipment manufacturer's Operator's Manuals.
- Close Needle Valve (4) to stop agitator motor.
- Turn Heater (7) off.

After use:

- Clean Wye Strainer (2). See Remove and Install Wye Strainer.
- Clean inside of Coatings Tank (5). See Clean Inside of Coating Tank.

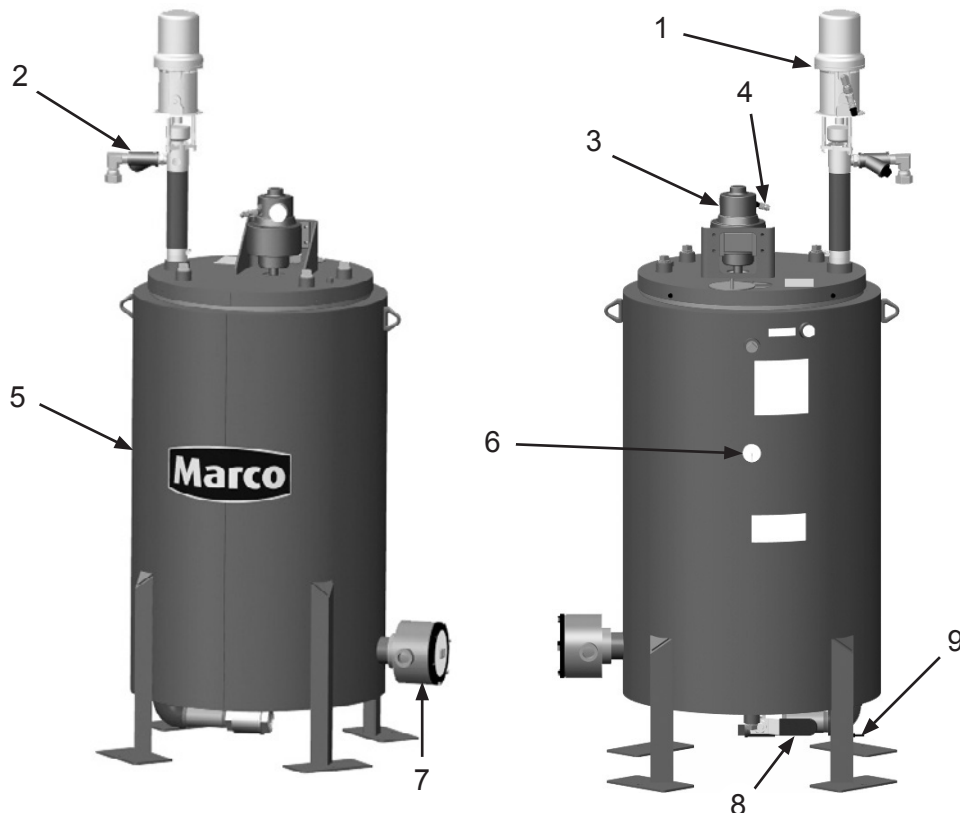

MAINTENANCE

Remove and Install Transfer Pump (If Equipped)

WARNING

Always depressurize the entire system, disconnect all power sources and lockout/tagout all components before any maintenance or troubleshooting is attempted. Failure to comply with the above warning could cause electrical shock and inadvertent activation of equipment resulting in death or serious injury.

- 1) Shut down air supply to the entire system. Follow shut down procedure in Original Equipment Manufacturers Operator's Manual.
- 2) Disconnect air hose from fitting (1).
- 3) Disconnect fluid hose from fitting (3).
- 4) Remove Wye Strainer (4). See Remove and Install Wye Strainer.
- 5) Remove Transfer Pump Assembly (2) by rotating entire assembly counter-clockwise. Lift and remove when free.

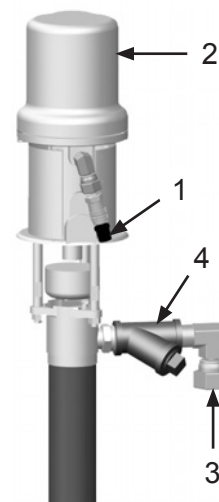

WARNING

Exposure to toxic fluids or fumes may occur during the normal operation of this system. Before attempting to fill, use, or service this system, read SDS's to know the specific hazards of the fluids you are using. Always use proper Personal Protective Equipment when attempting to fill, use, or service this system. Failure to comply with the above warning could result in death or serious injury.

- 6) Remove Foot Valve (5).
- 7) Loosen Bolt (6) and remove Adapter (7) from Pump Shaft (9).
- 8) Remove Tank Pump Spacer (8) from Pump Shaft (9).
- 9) Install parts in reverse order.

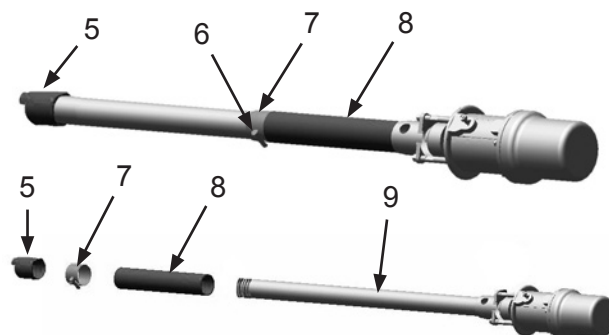

Remove and Install Wye Strainer

Note: When cleaning, always clean using a compatible cleaning Solution.

- 1) Shut down air supply to the entire system. See Original Equipment Manufacturers Operator's Manual.
- 2) Remove Plug (1).
- 3) Clean or replace Strainer Screen (2) as needed.
- 4) Disconnect hose from Swivel Elbow (5).
- 5) Remove Swivel Elbow (5).
- 6) Remove Wye Strainer (3) from Hex Nipple (4).
- 7) Install parts in reverse order.

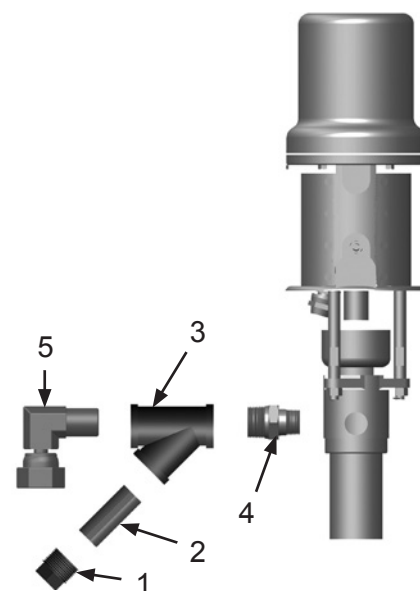

MAINTENANCE

Remove and Install Tank Heater

WARNING

W-562

Always depressurize the entire system, disconnect all power sources and lockout/tagout all components before any maintenance or troubleshooting is attempted. Failure to comply with the above warning could cause electrical shock and inadvertent activation of equipment resulting in death or serious injury.

WARNING

W-556

All electrical connections are to be made by a qualified electrician in accordance with all applicable codes, ordinances and good practices. Failure to comply with the above warning could result in death or serious injury.

WARNING

W-566

Exposure to toxic fluids or fumes may occur during the normal operation of this system. Before attempting to fill, use, or service this system, read SDS's to know the specific hazards of the fluids you are using. Always use proper Personal Protective Equipment when attempting to fill, use, or service this system. Failure to comply with the above warning could result in death or serious injury.

NOTICE

N-531

Drain tanks into container suitable for collecting fluids. Comply with all OSHA, local, City, State, Province, Country and jurisdiction regulations, ordinances and standards, related to your particular work area and environment.

- 1) Depressurize the entire system and disconnect all power sources.
- 2) Remove Square Head Plug (1) and drain antifreeze. Dispose of antifreeze properly.
- 3) Remove Heater Cover (2) and disconnect wires.
- 4) Remove conduit and wiring from Heater Body (3).

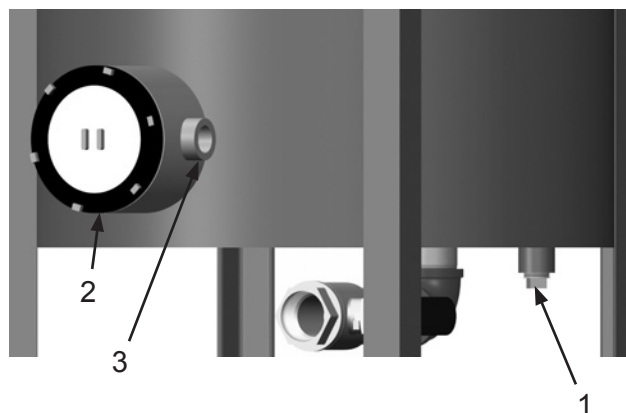

- 5) Remove Immersion Heater (4) by rotating counter-clockwise.
- 6) Install parts in reverse order using the following special instructions:
 - Apply PTFE Sealing Tape on threads of Immersion Heater (4).
 - See original equipment manufacturer's Operator's Manual for wiring scheme associated with heater.
 - Ensure heater cover is secure.
- 7) Fill antifreeze. See Fill Antifreeze.

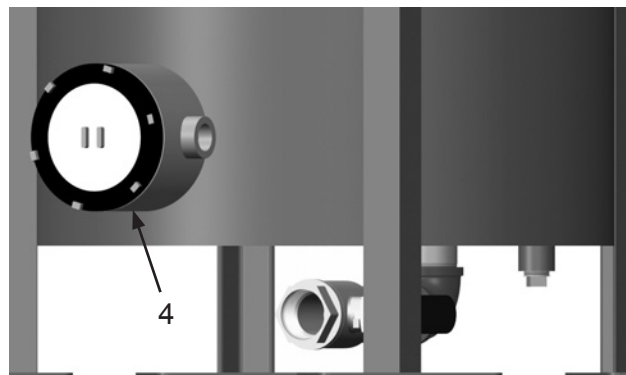

Fill Coating Tank

- 1) Shut down air supply to the entire system. See Original Equipment Manufacturers Operator's Manual.
- 2) Remove one of the unused 1" Plugs (1).
- 3) Pump in coating through plug opening.
- 4) Install Plug (1).

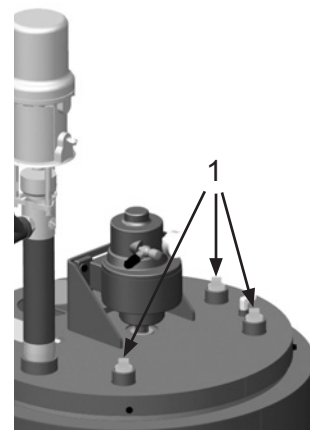

MAINTENANCE

Remove and Install Agitator Assembly

WARNING

W-562
Always depressurize the entire system, disconnect all power sources and lockout/tagout all components before any maintenance or troubleshooting is attempted. Failure to comply with the above warning could cause electrical shock and inadvertent activation of equipment resulting in death or serious injury.

WARNING

W-563
Moving parts can present an area where crushing, pinching, entanglement or amputation may occur. Do not place body parts or foreign objects in any area where there are moving parts. Failure to comply with the above warning could result in death or serious injury.

- 1) Shut down air supply to the entire system. See Original Equipment Manufacturers Operator's Manual.
- 2) Remove material from tank.
- 3) Remove Transfer Pump (3). See Remove and Install Transfer Pump.
- 4) Disconnect hose from Hex Nipple (1).
- 5) Remove four Bolts, Washers and Nuts (2).

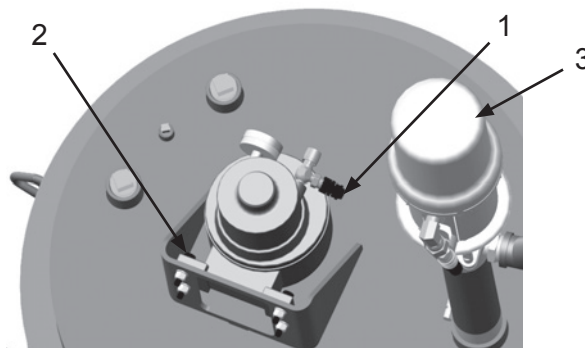

Note: Approximate weight of agitator assembly is 50 lbs. Use suitable lifting device to raise or maneuver agitator assembly.

- 6) Lift agitator assembly and secure below coupling on Lower Mixer Blade Shaft (6).
- 7) Loosen top two Bolts (5).
- 8) Remove Air Motor (4). Inspect, repair or replace as needed.
- 9) Lower Mixer Blade into tank.

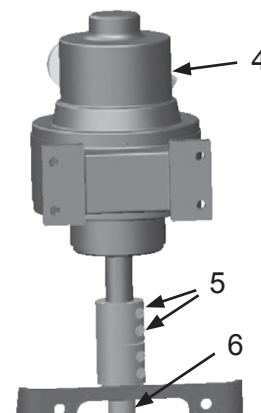

- 10) Remove Tank Lid (7). See Remove and Install Tank Lid.
- 11) Remove Mixer Blade. Inspect, repair or replace as needed.
- 12) Install parts in reverse.

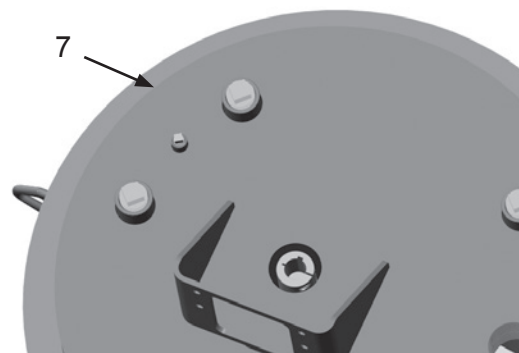

MAINTENANCE

Remove and Install Tank Lid

WARNING

W-562

Always depressurize the entire system, disconnect all power sources and lockout/tagout all components before any maintenance or troubleshooting is attempted. Failure to comply with the above warning could cause electrical shock and inadvertent activation of equipment resulting in death or serious injury.

WARNING

W-563

Moving parts can present an area where crushing, pinching, entanglement or amputation may occur. Do not place body parts or foreign objects in any area where there are moving parts. Failure to comply with the above warning could result in death or serious injury.

NOTICE

N-530

Label all hoses and connections to aid installation.

- 1) Shut down air supply to the entire system. See Original Equipment Manufacturers Operator's Manual.
- 2) Release fluid pressure and disconnect air hoses from Fittings (2) and (5).
- 3) Disconnect fluid hoses from Fittings (3) and (4).
- 4) Remove Transfer Pump Assembly (1).
- 5) See Remove and Install Transfer Pump.
- 6) Remove Agitator (6). See Remove and Install Agitator Assembly.

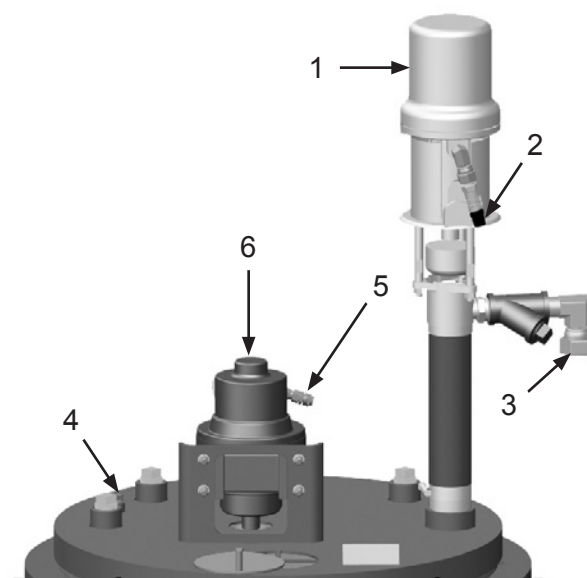

- 6) Remove four Screws (8) and Tank Lid (7).

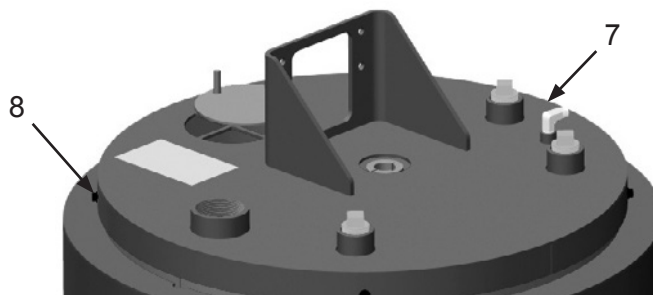

Note: Approximate weight of blade and lid assembly is 50 lbs. Use suitable lifting device to raise or maneuver blade and lid assembly.

- 7) Install parts in reverse order using the following special instructions:
 - With agitator assembly in tank, raise mixer blade shaft up through Opening (10) in lid and secure below Coupling (11) before placing lid on tank.
 - Align tank lid so that transfer pump assembly will be aligned with Hole (9) at bottom of tank.

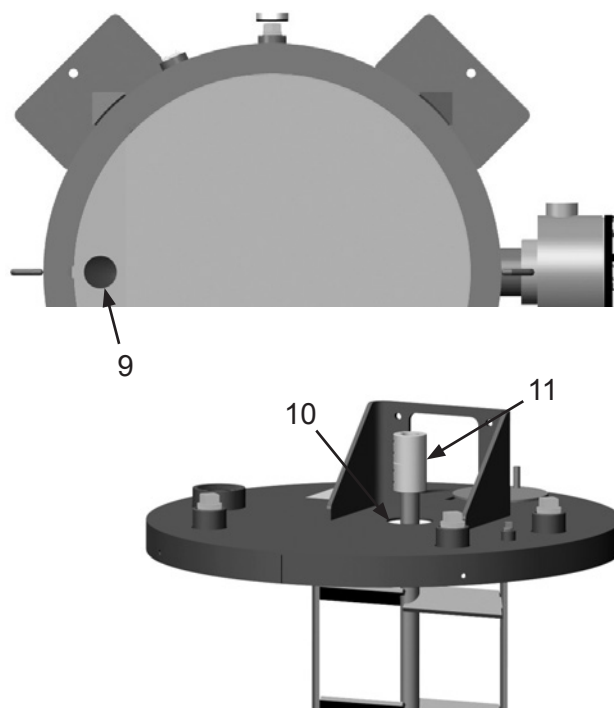

MAINTENANCE

Clean Inside of Coating Tank

WARNING

W-562
Always depressurize the entire system, disconnect all power sources and lockout/tagout all components before any maintenance or troubleshooting is attempted. Failure to comply with the above warning could cause electrical shock and inadvertent activation of equipment resulting in death or serious injury.

WARNING

W-561
Flammable fumes, such as solvent and paint fumes in the work area can present an ignition or explosion hazard if allowed to collect in adequate concentrations. To reduce conditions that could result in a fire or an explosion, provide adequate ventilation, eliminate all ignition or spark sources, keep the work area free of debris, store solvents and solvent contaminated rags in approved containers, follow proper grounding procedures, do not plug/unplug power cord or turn on/off power switches when flammable fumes are present, keep a working fire extinguisher or provide another fire suppression system in the work area. Cease all operations and correct condition if a spark or ignition source is identified during operation. Failure to comply with the above warning could result in death or serious injury.

Note: When cleaning, always clean using a compatible cleaning solution.

- 1) Depressurize the entire system and disconnect all power sources.
- 2) Open Ball Valve (2) to drain contents of coating tank. Store or dispose of contents properly.
- 3) Remove Tank Lid (1). See Remove and Install Tank Lid.
- 4) Clean Coating Tank (3) using a compatible cleaning solution and tools made of non-sparking materials.
- 5) Install parts in reverse order.



MAINTENANCE

Fill Antifreeze

WARNING

Exposure to toxic fluids or fumes may occur during the normal operation of this system. Before attempting to fill, use, or service this system, read SDS's to know the specific hazards of the fluids you are using. Always use proper Personal Protective Equipment when attempting to fill, use, or service this system. Failure to comply with the above warning could result in death or serious injury.

NOTICE

The outer water jacket must be filled with 50% glycol antifreeze/water solution before operating heating elements. Failure to do so will result in permanent damage or failure of the immersion heaters.

- 1) Remove Square Head Plug (1) to check antifreeze level at port (3). Fluid should be just below Port.
- 2) To add antifreeze, remove Square Head Relief Plug (2).
- 3) Add up to 45 gallons (170 liters) of a 50/50 blend Glycol Antifreeze/Water solution at Port (4) as needed.

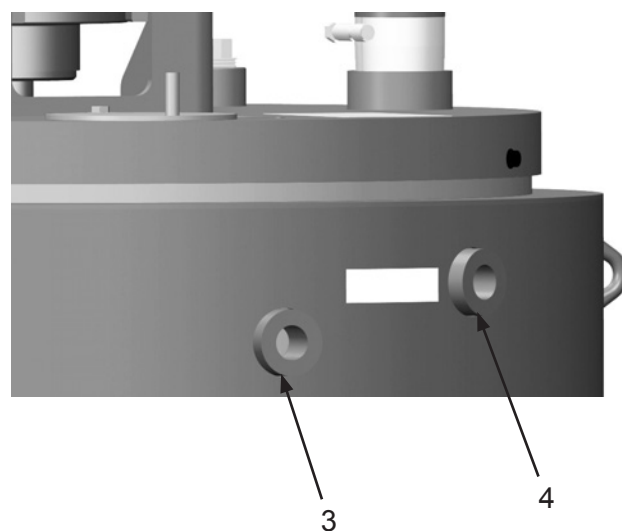
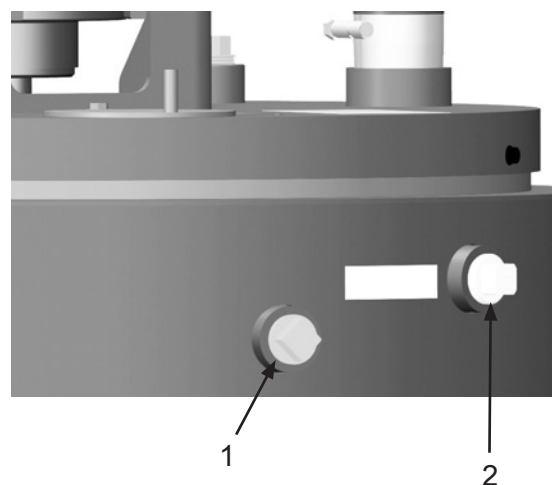

MAINTENANCE

Hazard Identification Decals

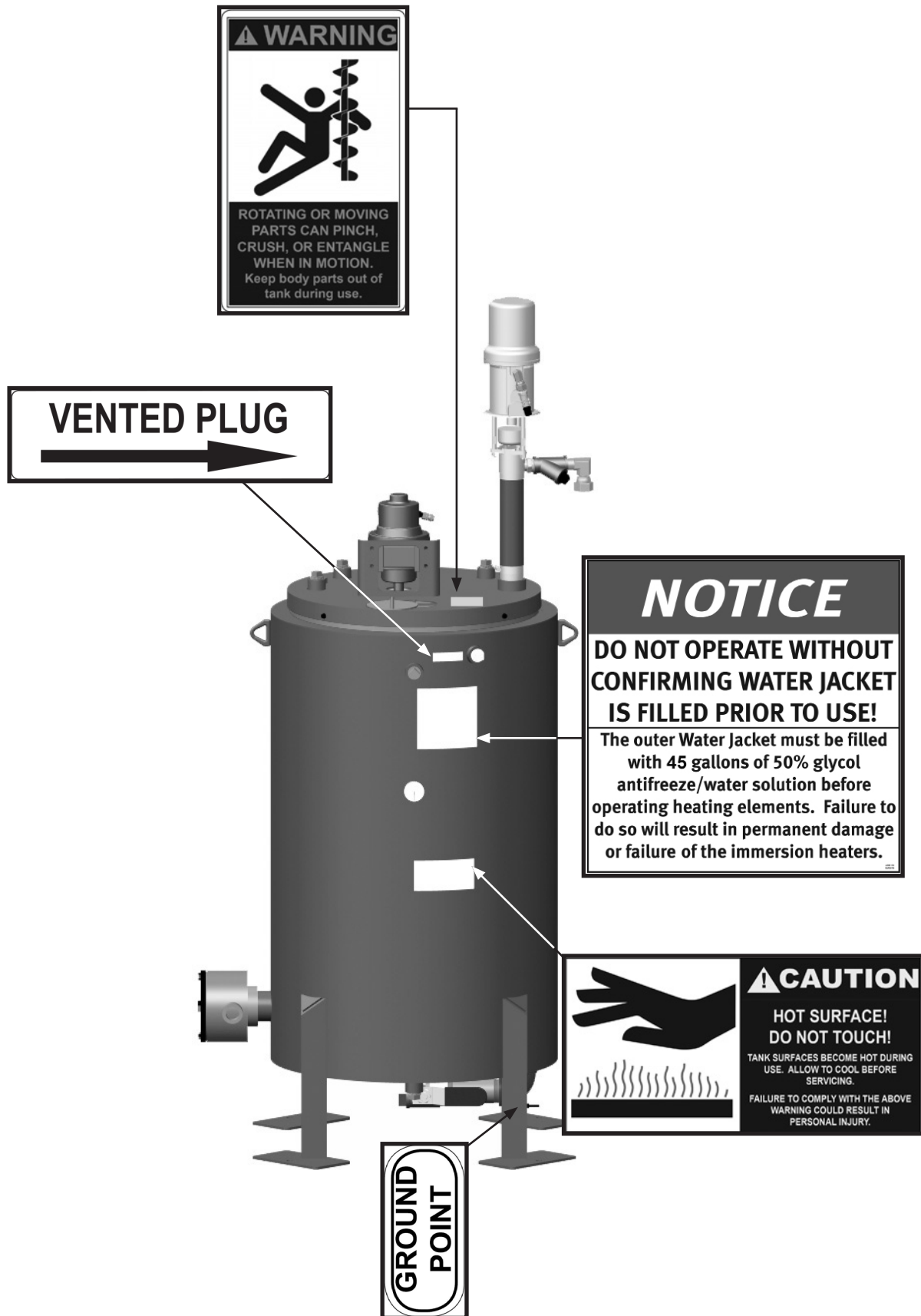

TROUBLESHOOTING

WARNING

W-562

Always depressurize the entire system, disconnect all power sources and lockout/tagout all components before any maintenance or troubleshooting is attempted. Failure to comply with the above warning could cause electrical shock and inadvertent activation of equipment resulting in death or serious injury.

SYMPTOM (Cause)

ACTION

Fluid Line Leaks

(Damaged components, loose fittings, worn parts)

Inspect all fluid hose connections and fluid fittings. Tighten fittings if leaks are present.

Inspect fluid hose for damage. Replace damaged fluid hose.

Transfer Pump will not start or runs poorly

(Damaged components, air supply, damaged hose, plugged Wye Strainer)

See original equipment Operator's Manual for service.

Check hose and hose connections between pumps and air manifold for leaks, blockage, or damage. Repair or replace as needed.

Inspect Wye Strainer for blockage or damage. Repair or replace as needed.

Tank Heaters are not heating fluid

(Insufficient power source, no power available, Insufficient amount of antifreeze)

See original equipment Operator's Manual for service.

Ensure system is connected to 240-Volt AC/480-Volt AC power source.

Check antifreeze level and add as needed.

Agitator Motor is not turning or rotates slowly

(Damaged components, air supply, viscosity)

Check air pressure and volume. Increase air pressure and volume by adjusting Needle Valve.

Inspect Air Motor for damage. Repair or replace as needed. See air motor Operator's Manual.

Coating viscosity too high. Ensure coating is at recommended temperature and proper viscosity. Check coating technical data sheets for proper temperature settings. Adjust temperature of heater, as necessary.

SPRAYMASTER® 60 GALLON HEATED COATINGS TANK SPECIFICATIONS

CAPACITY:	Inner Volume – 60 gallons (94.6 liters) Outer Jacket Capacity – 45 gallons (170 liters)
AIR REQUIREMENTS:	Clean, Dry, Compressed Air 60 CFM @ 50-150 psi 120 CFM @ 50-150 psi with optional Transfer Pump
ELECTRICAL SYSTEM:	240-Volt AC/20 AMP or 480-Volt AC/20 AMP
ANTIFREEZE SPECIFICATIONS:	45 gallons (170 liters) of a 50/50 blend Glycol Antifreeze/Water solution
AIR MOTOR:	Air Motor Gear Drive Max Air Consumption 60 CFM
DRY WEIGHT:	486 Pounds

SPRAYMASTER® 60 GALLON HEATED COATINGS TANK SPECIFICATIONS

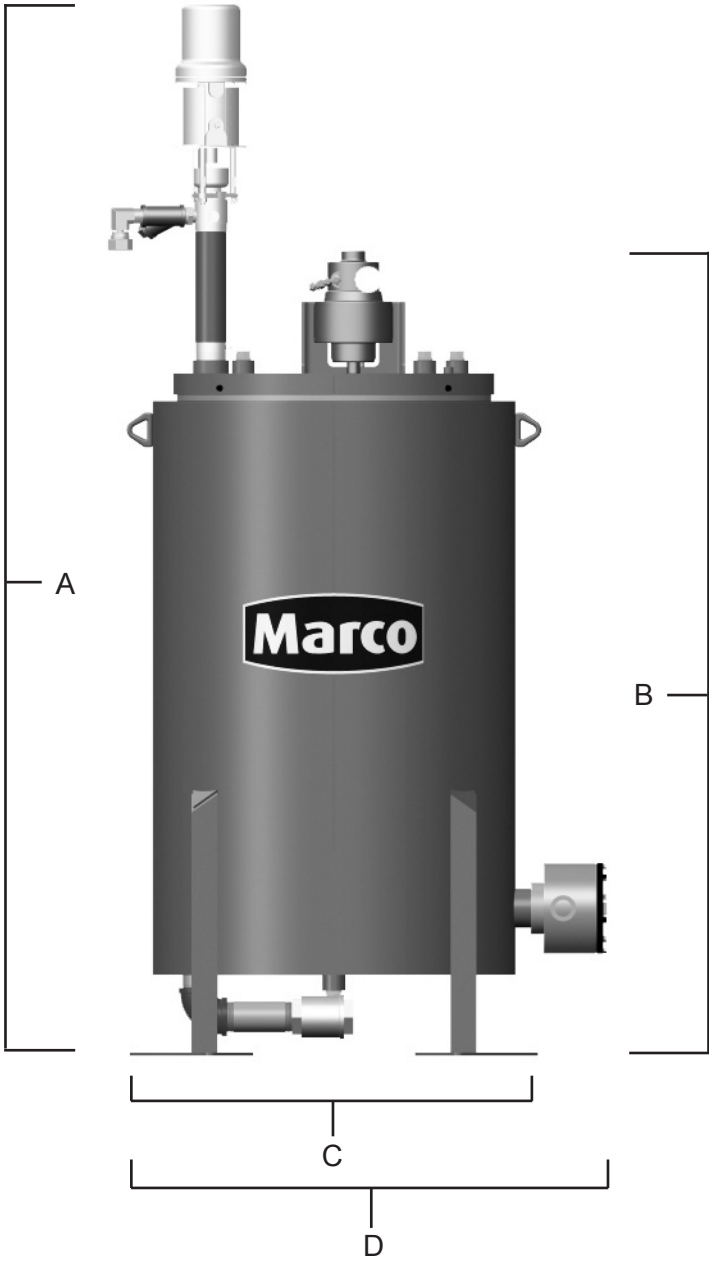

Overall Dimensions:
A: 81"
B: 62"
C: 32"
D: 37"

ASSEMBLY PART NUMBERS AND SCHEMATICS

Spraymaster® 60 Gallon Heated Coatings Tank 240/480-Volt AC Intrinsically Safe

Item #	Part #	Description
Fig. 1		
—	20100531	Spraymaster® 60 Gallon Heated Coatings Tank 240/480-Volt AC Intrinsically Safe – Complete
1	20100827	15:1 Gear Driven Air Motor <i>(Includes Item # 2)</i>
2	20BK350401	Air Motor Muffler Assembly
3	10103292	1/4" NPT Needle Valve
4	20PFHA24SA0402	1/8" x 1/4" NPT Hex Nipple
5	20100843	1" x 1" Shaft Coupling
6	20101104	Mixer Blade
7	1011901	1" NPT Square Head Plug <i>(Five Required)</i>
8	20PFHA25UA0404	1/4" NPT (M) 90° Elbow
9	20101050	60 Gallon Round HVL Lid Weldment
10	20100131	1/4-14 x 1-1/2" Self-Tapping Screw <i>(Four Required)</i>
11	20100494	240V/480V Intrinsically Safe Immersion Heater
12	20HHH0254F47	1/4" NPT 0-250 Thermometer
13	20100496	Heated Supply Tank
14	20100186	1" NPT Square Head Plug with 1/8" Relief Hole
15	20100173	Hot Surfaces Warning Label
16	2090116	Heater Notice Label
17	10101339	2" NPT 90° Elbow
18	20100146	2" x 6" NPT Nipple
19	1011604	2" Full Port Ball Valve
20	20100897	5/16-18 x 1-1/2" Hex Bolt <i>(Four Required)</i>
21	10L805003	5/16" Flat Washer <i>(Eight Required)</i>
22	20100900	5/16-18 Hex Lock Nut <i>(Four Required)</i>
—	1091130	Hazard Identification Decal
—	2090117	Hazard Identification Decal
—	209V580	Operator's Manual –AM Series Lubricated Air Motors
—	205M115	Features & Specifications Guide – Spraymaster® Heated Coating Tank
—	206M115	Part Numbers & Schematics Guide – Spraymaster® Heated Coating Tank
—	2090115	Operator's Manual – Spraymaster® Heated Coating Tank

PART NUMBERS & SCHEMATICS

Figure 1: Spraymaster® 60 Gallon Heated Coatings Tank 240/480-Volt AC Intrinsically Safe

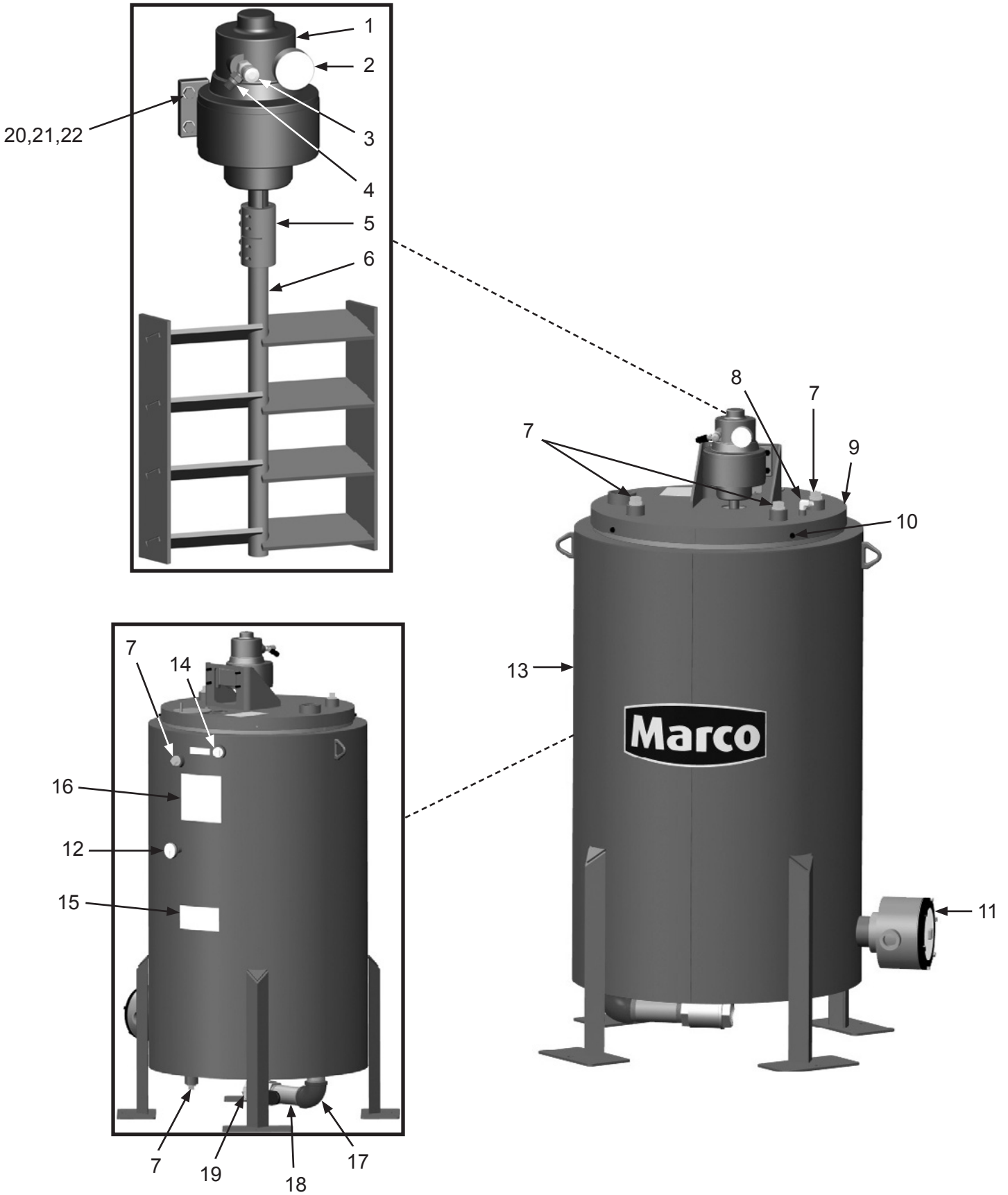

PART NUMBERS & SCHEMATICS

Figure 2: Spraymaster® 60 Gallon Heated Coatings Tank 240/480-Volt AC Intrinsically Safe with 5:1 Transfer Pump

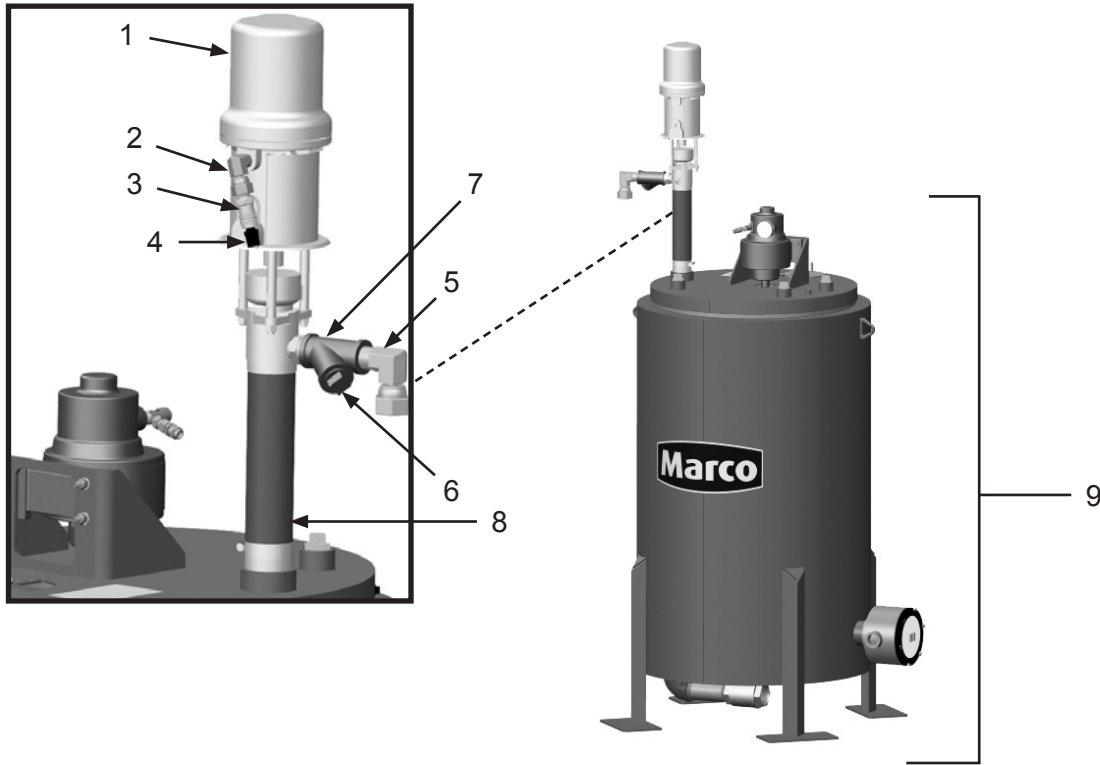

Item #	Part #	Description
Fig. 2		
—	20101225	Spraymaster® 60 Gallon Heated Coatings Tank 240-Volt AC Intrinsically Safe with 5:1 Transfer Pump – Complete
—	20101226	Spraymaster® 60 Gallon Heated Coatings Tank 480-Volt AC Intrinsically Safe with 5:1 Transfer Pump – Complete
1	20G248825	Monark® 5:1 Feed Pump
2	20PFHA60UA0606	3/8" NPT (M) x 3/8" (F) 90° Swivel Elbow
3	20100285	3/8" NPT 1/4" Male Quick Disconnect
4	20100286	3/8" NPT 1/4" Female Quick Disconnect
5	20PFHA60UA1616	1" NPT (M) x 1" (F) 90° Swivel Elbow
6	20000060	1" Wye Strainer
7	20PFHA24SA1612	1" x 3/4" NPT Hex Nipple
8	20101105	8-1/2" Tank Pump Spacer
9	20100531	Spraymaster® 60 Gallon Heated Coatings Tank 240-Volt AC Intrinsically Safe
—	209V510	Operator's Manual – Merkur® Displacement Pump
—	209V511	Operator's Manual – Graco® Feed and Solvent Flush Kits
—	209V513	Operator's Manual – 5:1 Ratio Monark® Pump
—	209V580	Operator's Manual – AM Series Lubricated Air Motors
—	205M115	Features & Specifications Guide - Spraymaster® Heated Coating Tank
—	206M115	Part Numbers & Schematics Guide – Spraymaster® Heated Coating Tank
—	2090115	Operator's Manual – Spraymaster® Heated Coating Tank

PART NUMBERS & SCHEMATICS

Figure 3: Spraymaster® 60 Gallon Heated Coatings Tank 240/480-Volt AC Intrinsically Safe with 10:1 Transfer Pump

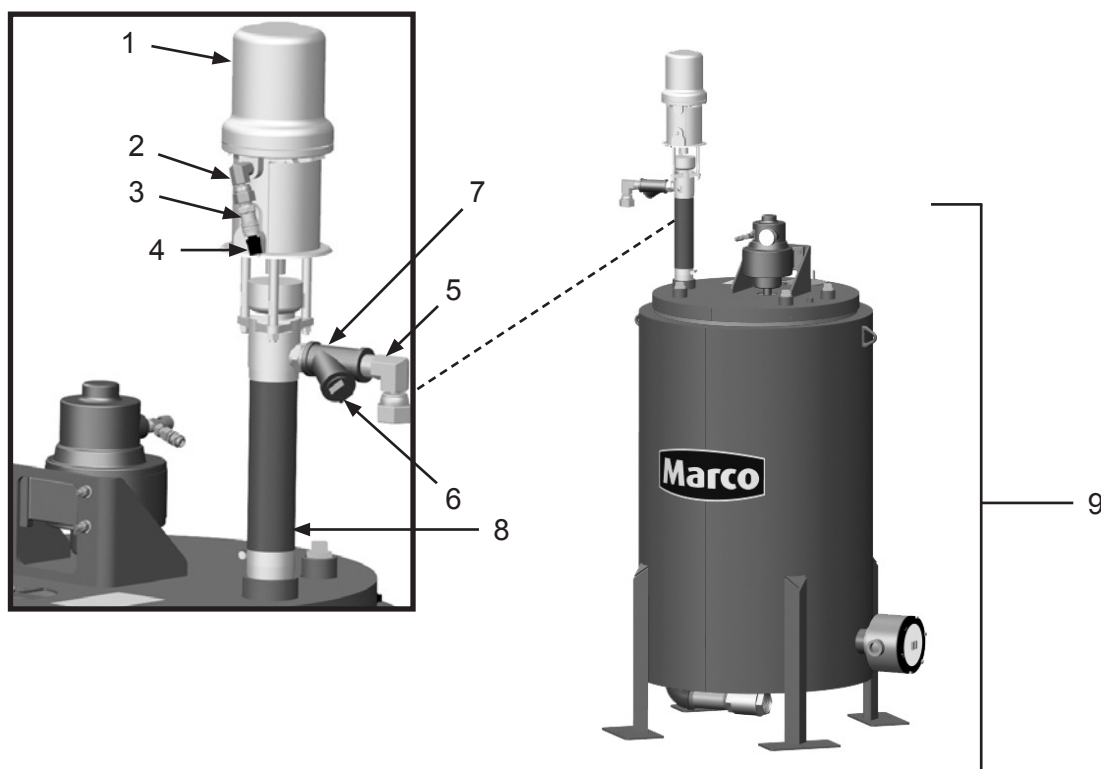

Item #	Part #	Description
Fig. 3		
—	20101227	Spraymaster® 60 Gallon Heated Coatings Tank 240-Volt AC Intrinsically Safe with 10:1 Transfer Pump – Complete
—	20101228	Spraymaster® 60 Gallon Heated Coatings Tank 480-Volt AC Intrinsically Safe with 10:1 Transfer Pump – Complete
1	20G256433	President® 10:1 Feed Pump
2	20PFHA60UA0606	3/8" NPT (M) x 3/8" (F) 90° Swivel Elbow
3	20100285	3/8" NPT 1/4" Male Quick Disconnect
4	20100286	3/8" NPT 1/4" Female Quick Disconnect
5	20PFHA60UA1616	1" NPT (M) x 1" (F) 90° Swivel Elbow
6	20000060	1" Wye Strainer
7	20PFHA24SA1612	1" x 3/4" NPT Hex Nipple
8	20101105	8-1/2" Tank Pump Spacer
9	20100531	Spraymaster® 60 Gallon Heated Coatings Tank 240-Volt AC Intrinsically Safe
—	209V510	Operator's Manual – Merkur® Displacement Pump
—	209V511	Operator's Manual – Graco® Feed and Solvent Flush Kits
—	209V514	Operator's Manual – 10:1 Ratio President® Pump
—	209V580	Operator's Manual – AM Series Lubricated Air Motors
—	205M115	Features & Specifications Guide - Spraymaster® Heated Coating Tank
—	206M115	Part Numbers & Schematics Guide – Spraymaster® Heated Coating Tank
—	2090115	Operator's Manual – Spraymaster® Heated Coating Tank

PART NUMBERS AND SCHEMATICS

Figure 4: Wye Strainer

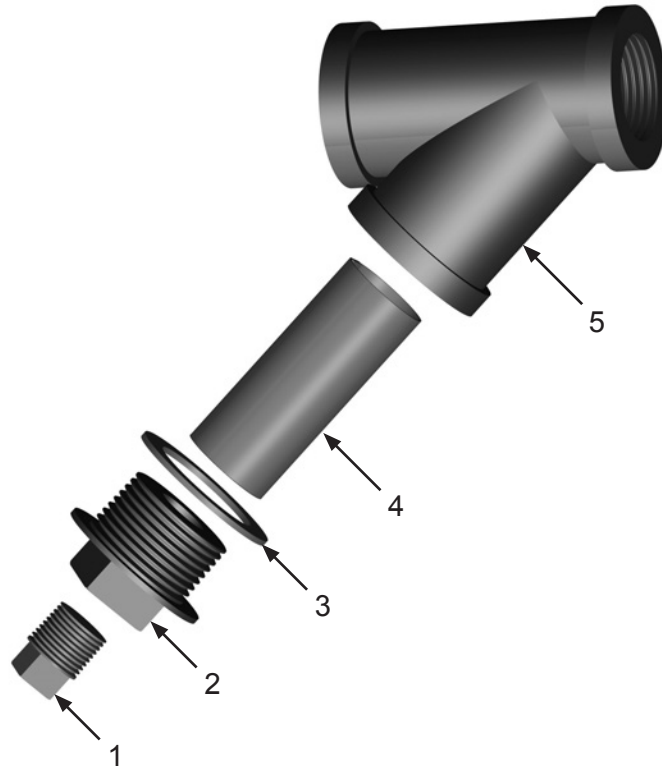

Item #	Part #	Description
Fig. 4		
1	20PFHA24ST06	3/8" Pipe Plug
2	1011901	1" NPT Pipe Plug
3	20100666	Y-Strainer Gasket 1-3/4" O.D. x 1-1/4" I.D.
4	20100470	Strainer Screen
5	20000060	1" Wye Strainer

ADDITIONAL TECHNICAL DATA

The associations listed below offer information, materials and videos pertaining to abrasive blasting and safe operating practices.

- **American Society for Testing and Materials (ASTM)**
100 Barr Harbor Drive
West Conshohocken, PA 19428-2959

Phone: (610) 832-9585
FAX: (610) 832-9555
www.astm.org
- **Occupational Safety & Health Administration (OSHA)**
United States
Department of Labor
200 Constitution Avenue
Washington, DC 20210

Phone: (800) 321-OSHA
(800) 321-6742
www.osha.gov
- **The National Board of Boiler & Pressure Vessel Inspectors**
1055 Crupper Avenue
Columbus, Ohio 4322

Phone: (614) 888-8320
FAX: (614) 888-0750
www.nationalboard.org
- **National Association of Corrosion Engineers (NACE)**
1440 South Creek Drive
Houston, TX 77084-4906

Phone: (281) 228-6200
FAX: (281) 228-6300
www.nace.org
- **The Society for Protective Coatings (SSPC)**
40-24th Street, 6th Floor
Pittsburgh, PA 15222-4656

Phone: (412) 281-2331
FAX: (412) 281-9992
www.sspc.org
- **American National Standards Institute (ANSI)**
1899 L Street, NW, 11th Floor
Washington, DC 20036

Phone: (202) 293-8020
FAX: (202) 293-9287
www.ansi.org

LIMITED WARRANTY

Seller warrants to the original purchaser that the Product covered by this Limited Warranty will remain free from defects in workmanship or material under normal commercial use and service for a period of one year from the date of shipment to the original Purchaser. This Warranty shall not apply to defects arising, in whole or in part, from any accident, negligence, alteration, misuse or abuse of the Product, operation of the Product which is not in accordance with applicable instructions or manuals or under conditions more severe than, or otherwise exceeding, those set forth in the written specifications for the Product, nor shall this Warranty extend to repairs or alterations of the Product and/or any maintenance part by persons other than Seller or Seller's authorized representatives. This warranty does not apply to accessory items. Further, this Warranty does not apply to damage or wear to the surface finish or appearance of the Product or normal wear and tear to the Product. This Warranty is limited to a purchaser who purchases the Product either directly from the Seller or from one of Seller's "Authorized Distributors". An Authorized Distributor is a Seller approved distributor that purchases the Product directly from the Seller for the sole purpose of re-selling the Product at retail, without any use or modifications whatsoever, to an end-purchaser. This warranty is specifically non-assignable and non-transferable.

DISCLAIMER OF WARRANTY

The foregoing Limited Warranty is exclusive and is in lieu of all other warranties, whether oral or written and whether express, implied, or statutory. SELLER HEREBY DISCLAIMS ALL OTHER WARRANTIES, INCLUDING BUT NOT LIMITED TO THE WARRANTIES OF MERCHANTABILITY AND/OR FITNESS FOR A PARTICULAR PURPOSE AND ALL SUCH OTHER WARRANTIES ARE HEREBY EXCLUDED AND ARE INAPPLICABLE TO THE PRODUCT. Seller makes no warranties or representations of any kind concerning respirators, or equipment made by other manufacturers. Seller's agents and representatives are not authorized to offer any further warranties.

EXCLUSIVE REMEDY FOR WARRANTY CLAIMS

THE SOLE AND EXCLUSIVE REMEDY UNDER THE FOREGOING LIMITED WARRANTY, AND TO THE EXTENT PERMITTED BY LAW, ANY WARRANTY OR CONDITION IMPLIED BY LAW, COVERING THIS PRODUCT SHALL BE, AT THE SELLER'S OPTION, THE REPAIR OR REPLACEMENT, FREE OF CHARGE, F.O.B. POINT OF MANUFACTURE, OF ANY DEFECTIVE PART OR PARTS OF THE PRODUCT THAT WERE MANUFACTURED BY SELLER, AND WHICH ARE RETURNED TO SELLER AT SELLER'S PRINCIPAL PLACE OF BUSINESS, POSTAGE PREPAID BY THE PURCHASER. THIS SOLE AND EXCLUSIVE REMEDY IS CONDITIONED UPON PURCHASER'S PROMPT WRITTEN NOTICE TO SELLER AT SELLER'S PLACE OF BUSINESS THAT A DEFECT HAS BEEN DISCOVERED, TOGETHER WITH A REASONABLY DETAILED DESCRIPTION OF THE DEFECT IN THE PRODUCT, PROOF OF PURCHASE OF THE PRODUCT, AND THE MODEL AND IDENTIFICATION NUMBER OF THE PRODUCT WITHIN THIRTY (30) DAYS AFTER DISCOVERY OF THE DEFECT, OTHERWISE SUCH CLAIMS SHALL BE DEEMED WAIVED. NO ALLOWANCE WILL BE GRANTED FOR ANY REPAIRS OR ALTERATIONS MADE BY PURCHASER OR OTHERS WITHOUT SELLER'S PRIOR WRITTEN CONSENT. IF SUCH NOTICE IS TIMELY GIVEN, SELLER WILL HAVE THE OPTION TO EITHER MODIFY THE PRODUCT OR COMPONENT PART THEREOF TO CORRECT THE DEFECT, REPLACE THE PRODUCT OR PART WITH COMPLYING PRODUCTS OR PARTS, OR REFUND THE AMOUNT PAID FOR THE DEFECTIVE PRODUCT, ANY ONE OF WHICH WILL CONSTITUTE THE SOLE LIABILITY OF SELLER AND FULL SETTLEMENT OF ALL CLAIMS. IN NO EVENT SHALL SELLER BE LIABLE FOR ANY OBLIGATION GREATER THAN THE ORIGINAL PURCHASE PRICE OF THE PRODUCT UNDER THIS WARRANTY. PURCHASER SHALL AFFORD SELLER PROMPT AND REASONABLE OPPORTUNITY TO INSPECT THE PRODUCT FOR WHICH A CLAIM IS MADE. THE SOLE PURPOSE OF THE FOREGOING STIPULATED EXCLUSIVE REMEDY SHALL BE TO REPAIR OR REPLACE DEFECTIVE PRODUCTS OR COMPONENTS THEREOF, OR TO REFUND PURCHASER THE PURCHASE PRICE THEREOF. THIS STIPULATED EXCLUSIVE REMEDY SHALL NOT BE DEEMED TO HAVE FAILED OF ITS ESSENTIAL PURPOSE SO LONG AS SELLER IS WILLING AND ABLE TO REPAIR OR REPLACE THE DEFECTIVE PARTS OR REFUND THE PURCHASE PRICE IN ACCORDANCE WITH THE TERMS HEREOF. PRODUCTS THAT HAVE BEEN REPAIRED OR REPLACED UNDER THIS WARRANTY DO NOT RECEIVE A NEW WARRANTY AND ARE ONLY COVERED BY THE REMAINING PORTION OF THE ORIGINAL WARRANTY.

LIMITATION OF REMEDIES

The foregoing stipulated exclusive remedy is in lieu of all other remedies for breach of contract, warranty, and/or tort or otherwise. Seller shall not be liable, either directly or indirectly, for any consequential, incidental or special losses or damages of Purchaser, including but not limited to the Purchaser's expenses for downtime or for making up downtime, damages for which the Purchaser may be liable to other persons and/or entities, damages to property, and injury to or death of any persons and/or any claims for incidental or consequential damages, including but not limited to loss of profits, regardless of whether Seller has been informed of the possibility of such damages. Seller neither assumes, nor authorizes any person to assume for it, any other liability in connection with the sale or use of any Products covered by the foregoing Warranty and Disclaimers, and there are no oral agreements relating to remedies which are collateral to or which affect this limitation.

GLOBAL HEADQUARTERS

- 3425 East Locust Street
Davenport, IA 52803

ph: 800.BLAST.IT (800.252.7848)

ph: 563.324.2519

fax: 563.324.6258

GULF STATES HEADQUARTERS

- 701 East Boulevard
Deer Park, TX 77536

ph: 800.BLAST.IT (800.252.7848)

ph: 281.930.0905

fax: 281.542.0736

REGIONAL BRANCH OFFICES

- **Iowa**
Davenport
- **Louisiana**
Gonzales
Lafayette
- **Ohio**
Youngstown
- **Texas**
Beaumont
Corpus Christi
Deer Park



ABRASIVES

BLASTING

COATING

DUST COLLECTORS

ENGINEERED SYSTEMS

RENTAL

SAFETY

SERVICE & REPAIR

VACUUMS

50+ NATIONWIDE SHIPPING LOCATIONS



★ Marco Regional Branch Offices
and Shipping Locations

● Direct Shipping Locations

CONTACT MARCO

800.BLAST.IT

(800.252.7848)

563.324.2519

FAX: 563.324.6258

WWW.MARCO.US

SALES@MARCO.US