



BLASTMASTER® 6.0 CU. FT. C-SERIES ABRASIVE BLASTING POT



BUILT MARCO TOUGH
MARCO MANUFACTURED

PART NUMBERS AND SCHEMATIC GUIDE

Company Profile

Since 1944, Marco has developed a strong tradition of providing innovative and reliable products and services to the surface preparation and protective coatings industries. We are the world's premier provider of Abrasives, Blasting Equipment, Coating Equipment, Engineered Systems, Rental Equipment, Safety Equipment, Service, and Repair.

Through innovative designs and a total commitment to quality, Marco manufactures products that increase production rates, create a safer workplace, and reduce maintenance costs. Marco's industry experience, manufacturing capabilities, legendary customer service, product availability, logistics services, and technology leadership is your assurance that we deliver high quality products and services, providing the best value to you, our customer.

The Marco Difference

- **Industry Experience** – With Marco on your team, you have access to expertise which can only come from decades of industry leadership. We have organized our engineering department, production specialists, customer operations, and safety support into a “Center of Competence.” As a Marco customer, you have access to hundreds of years of cumulative experience related to your operations.
- **Manufacturing Excellence** – Marco is a U.S. based, ISO 9001:2008 certified manufacturer of equipment for the Surface Preparation and Protective Coatings industries. Marco's engineers benchmark the industry to ensure that we design and manufacture superior products that set the “Gold Standard” for performance, safety, and quality.
- **Legendary Customer Service** – Marco's legendary customer service team is staffed by friendly, highly-trained individuals who are focused on providing the highest level of product support, order accuracy, and customer satisfaction.
- **Product Availability** – We stock over 10,000 SKU's and have over 45 shipping locations to serve North American and International markets for all major brands of blasting and painting equipment. As the largest provider of surface preparation and protective coatings equipment in the world, our inventory levels and product availability are unmatched.
- **Logistics Services** – Marco's in-house logistics team is dedicated to moving your shipment anywhere in the world. We move over 14,000 truckloads every year, allowing you to save on freight costs by leveraging our buying power. Lower your process costs with a single invoice, which includes product and freight.
- **Technology Leadership** – Our website provides: Operator's Manuals, Part Numbers and Schematics Guides, MSDS information, and Features and Specifications Guides, providing access to information 24/7. Our Extranet application allows you to receive quotes and place orders online. Our Intranet maintains a complete record of your purchase history to assist with ongoing support of your existing equipment and future purchasing decisions.

Vision Statement

Marco is the world's premier provider of Abrasives, Blasting Equipment, Coating Equipment, Engineered Systems, Rental Equipment, Safety Equipment, Service, and Repair.

Mission Statement

Marco provides strong leadership and innovation to the surface preparation and protective coatings industries. We dedicate our efforts to the continuous improvement of our products, services, processes, people, and most importantly, the quality of our customer's experience.

Quality Statement

Marco is committed to providing superior quality in the design, manufacturing, distribution, rental, service, and repair of our products. Our ISO 9001:2008 certification extends throughout all operations in all locations. Continuous improvement of our processes and supply chain Integration comprise the core of our business strategy for delivering exceptional quality and value in all Marco products and services.

Management Philosophy

We are a company dedicated to the success of every customer and associate. We discuss, debate, challenge, measure, and test our ideas. We will be boundless and limitless in our passion to improve. Through sound leadership and dedicated associates, we will ensure a long term, profitable future for Marco, our associates, customers, and suppliers.

TABLE OF CONTENTS

Part Numbers	4
Part Numbers and Schematics	5
Inspection Door Assembly	5
Pop-up Valve Assembly	5
Blastmaster® 6.0 Cu. Ft. C-Series Abrasive Blasting Pot – Pneumatic	6
Blastmaster® 6.0 Cu. Ft. C-Series Abrasive Blasting Pot – Electric	8
Pusher Line Assembly	10
Exhaust Muffler Assembly	11
Blastmaster® 125P Remote Control System	12
1-1/2" Inlet Valve	14
1" Outlet Valve	15
Abrasive Trap	16
120-Volt AC to 12-Volt AC Power Converter	17
12-Volt DC Blastmaster® 125E Remote Control System	18
12-Volt DC 190 Electric Control Assembly	20
12-Volt DC 190 Electric Solenoid	21
120-Volt AC Blastmaster® 125E Remote Control System	22
12-Volt AC 190 Electric Control Assembly	24
12-Volt AC 190 Electric Solenoid	25
Blastmaster® Regulator Abrasive Metering Valve	26
Optional Accessories	28
1-1/2" Extractor Abrasive Blasting Pot Moisture Separator	28
Lid and Screen	29
Loading Skid	30

PART NUMBERS

BLASTMASTER® 6.0 CU. FT. C-SERIES ABRASIVE BLASTING POT

Part Numbers	Power Source	Blastmaster® Remote Control System	Blastmaster® Remote Control Switch	Blastmaster® Regulator Abrasive Metering Valve	1-1/2" Extractor Abrasive Blasting Pot Moisture Separator
1006008	Pneumatic	125P	150P	X	
1006008PKA	Pneumatic	125P	150P	X	X
1006002	12-Volt DC	125E	151E	X	
1006002PKA	12-Volt DC	125E	151E	X	X
1006004	120-Volt AC	125E	151E	X	
1006004PKA	120-Volt AC	125E	151E	X	X

PART NUMBERS AND SCHEMATICS

Figure 1: Inspection Door Assembly

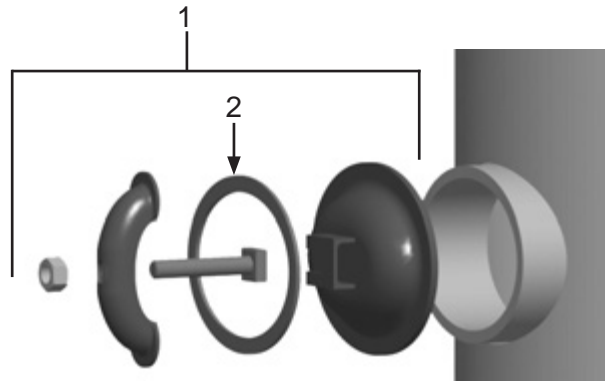

Item #	Part #	Description
Fig. 1		
1	1006200	6" x 8" Inspection Door Assembly
2	1006201	Gasket

Figure 2: Pop-up Valve Assembly

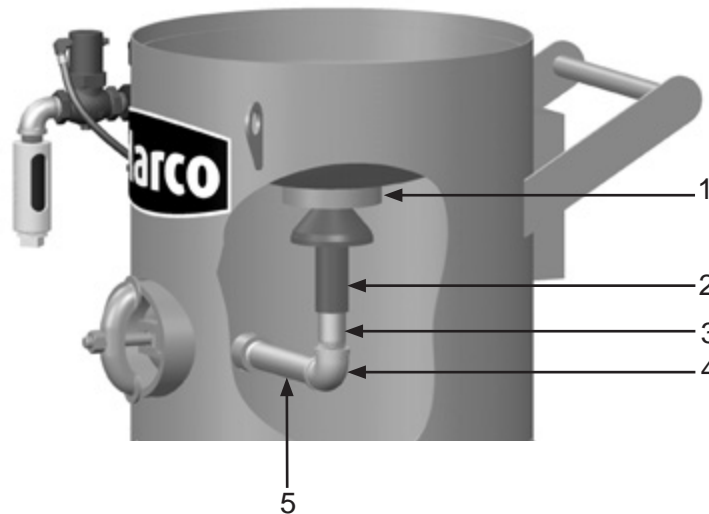

Item #	Part #	Description
Fig. 2		
1	1006050	Pop-Up Valve Seat
2	1006020	Pop-Up Valve – External Sleeve
3	1011200	1-1/4" NPT x 7" Toe Nipple
4	1006204	1-1/4" 90° Elbow
5	1011214	1-1/4" NPT x 10" Pipe Nipple

PART NUMBERS AND SCHEMATICS

Blastmaster® 6.0 Cu. Ft. C-Series Abrasive Blasting Pot – Pneumatic

Item #	Part #	Description
Fig. 3		
1	1012050	1" Outlet Valve (See Literature 106M014)
2	10CL18	18" Control Line
3	1011801	1" Galvanized Street Elbow
4	1011100	Abrasive Blasting Pot Muffler (See Fig. 6)
5	1012200	1-1/2" Inlet Valve (See Literature 106M014)
6	1014015	1-1/2" Galvanized Close Nipple (Three Required)
7	1011201	1-1/4" Galvanized Close Nipple (Three Required)
8	1011501	1-1/2" (M) x 1-1/4" (F) Galvanized Hex Bushing (Three Required)
9	1014000	Blastmaster® Regulator Abrasive Metering Valve
10	10SB1	1-1/4" Brass Tank Coupling
11	1011202	1-1/4" x 6" Galvanized Nipple
12	1006205	1" Wheel Clip (Four Required)
13	1006064	16" Wheel (Two Required)
14	1006312	1-1/2" I.D. Pusher Line Assembly (See Fig. 5)
15	1011603	1-1/2" Full Port Ball Valve
16	1011804	1-1/2" 90° Galvanized Elbow with Side-out
17	1012000	1" Abrasive Trap
18	1011901	1" Galvanized Square Head Pipe Plug
19	1011816	1" Galvanized Pipe Tee
20	1012151	1" Galvanized Close Nipple
—	105M072	Features and Specifications Guide – Blastmaster® 6.0 Cu. Ft. C-Series Abrasive Blasting Pot
—	106M072	Part Numbers & Schematics Guide – Blastmaster® 6.0 Cu. Ft. C-Series Abrasive Blasting Pot
—	1090072	Operator's Manual – Blastmaster® 6.0 Cu. Ft. C-Series Abrasive Blasting Pot
—	105M023	Features and Specifications Guide – Blastmaster® 150P Remote Control Switch
—	106M023	Part Numbers & Schematics Guide – Blastmaster® 150P Remote Control Switch
—	1090023	Operator's Manual – Blastmaster® 150P Remote Control Switch

PART NUMBERS AND SCHEMATICS

Figure 3: Blastmaster® 6.0 Cu. Ft. C-Series Abrasive Blasting Pot – Pneumatic

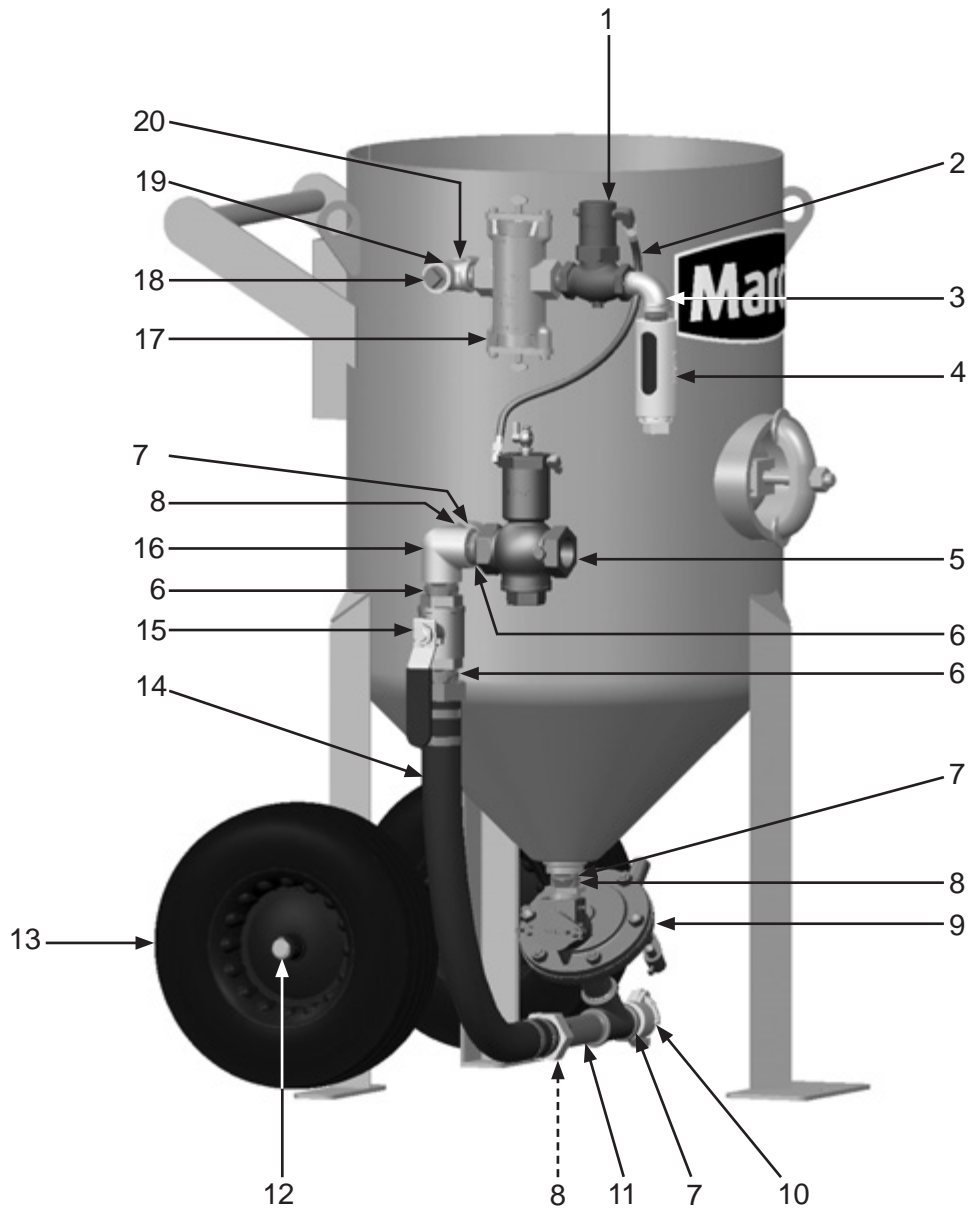

PART NUMBERS AND SCHEMATICS

Blastmaster® 6.0 Cu. Ft. C-Series Abrasive Blasting Pot – Electric

Item #	Part #	Description	Item #	Part #	Description
Fig. 4			—	105M063	Features and Specifications Guide – Blastmaster® 151E Remote Control Switch
1	1012050	1" Outlet Valve	—	105M072	Features & Specifications Guide – Blastmaster® 6.0 Cu. Ft. C-Series Abrasive Blasting Pot
2	10CL18	18" Control Line	—	106M063	Part Numbers & Schematics Guide – Blastmaster® 151E Remote Control Switch
3	1011801	1" Galvanized Street Elbow	—	106M072	Part Numbers & Schematics Guide – Blastmaster® 6.0 Cu. Ft. C-Series Abrasive Blasting Pot
4	1011100	Abrasive Blasting Pot Muffler (See Fig. 6)	—	1090063	Operator's Manual – Blastmaster® 151E Remote Control Switch
5	10AH025	1/4" Push-on Air Hose (Per Foot)	—	1090072	Operator's Manual – Blastmaster® 6.0 Cu. Ft. C-Series Abrasive Blasting Pot
6	1012200	1-1/2" Inlet Valve			
7	1014015	1-1/2" Close Galvanized Nipple (Three Required)			
8	1014000	Blastmaster® Regulator Abrasive Metering Valve			
9	10SB1	1-1/4" Brass Tank Coupling			
10	1011201	1-1/4" Galvanized Close Nipple (Three Required)			
11	1011202	1-1/4" x 6" Galvanized Nipple			
12	1011501	1-1/2" (M) x 1-1/4" (F) Galvanized Hex Bushing (Three Required)			
13	1006205	1" Wheel Clip (Four Required)			
14	1006064	16" Wheel (Two Required)			
15	1006312	1-1/2" I.D. Pusher Line Assembly (See Fig. 5)			
16	1011603	1-1/2" Full Port Ball Valve			
17	1011804	1-1/2" 90° Galvanized Elbow with Side Out			
18	1012000	1" Abrasive Trap			
19	1019001	12-Volt DC 190 Electric Control Assembly			
—	1019002	12-Volt AC 190 Electric Control Assembly			
20	1011901	1" Galvanized Square Head Pipe Plug			
21	1011816	1" Galvanized Pipe Tee			
22	1012151	1" Galvanized Close Nipple			
23	1019044	1/4-20 x 1-3/4" Zinc Bolt (Two Required)			
24	1012323	1/4-20 Zinc Lock Nut with Nylon Insert (Two Required)			
25	1030020	Blastmaster® 120VAC-12VAC Converter (Optional)			
26	1012154	1/4-20 x 1" Hex Bolt (Four Required)			
27	1014017	1/4" Flat Washer (Four Required)			

PART NUMBERS AND SCHEMATICS

Figure 4: Blastmaster® 6.0 Cu. Ft. C-Series Abrasive Blasting Pot – Electric

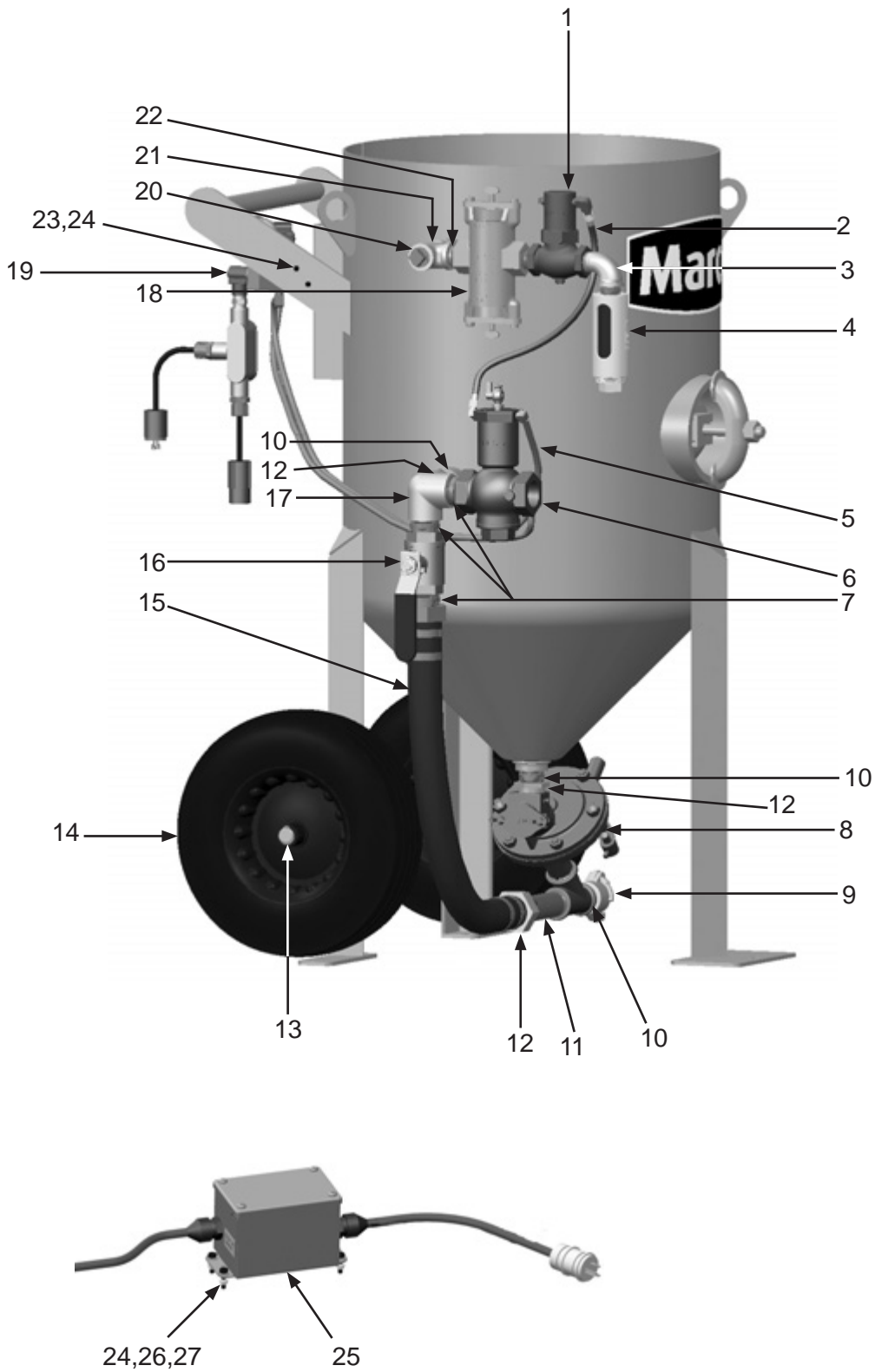

PART NUMBERS AND SCHEMATICS

Figure 5: Pusher Line Assembly

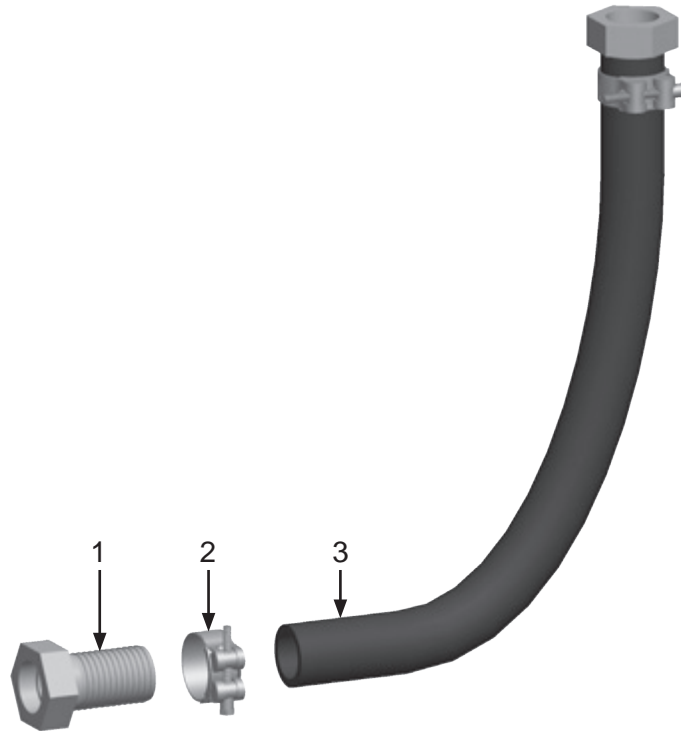

Item #	Part #	Description
Fig. 5		
—	1006312	1-1/2" I.D. Pusher Line Assembly <i>Includes Item #: 1, 2, and 3 (Quantity of Three Feet)</i>
1	10SFE4	1-1/2" Female Swivel Air Hose End <i>(Two Required)</i>
2	10103738	1-1/2" T-Bolt Hose Clamp <i>(Two Required)</i>
3	10AH112B	1-1/2" I.D. Air Hose
—	10SFE4G	Gasket for 10SFE4 Swivel Air Hose End <i>(Not Shown)</i>
—	1090059	Technical Data Sheet – Pusher Line Assemblies

PART NUMBERS AND SCHEMATICS

Figure 6: Exhaust Muffler Assembly

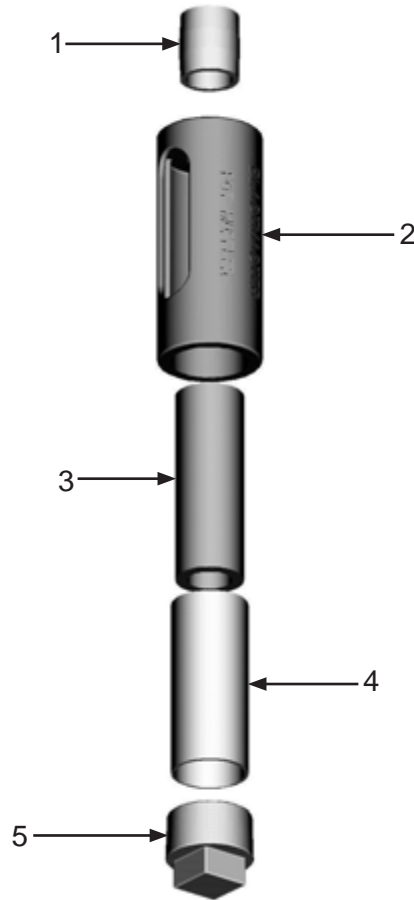

Item #	Part #	Description
Fig. 6		
—	1011100	Blastmaster® Abrasive Blasting Pot Muffler – Complete
1	1012151	1" Close Nipple
2	1011102	Body
3	1011103	Filter Element
4	1011104	Screen
5	1011101	1-1/2" Pipe Plug
—	1011105	Blastmaster® Abrasive Blasting Pot Muffler Service Kit <i>Includes Item #'s: 3 (Quantity of Three), 4, and 5</i>
—	105M347	Features and Specifications Guide – Blastmaster® Abrasive Blasting Pot Mufflers
—	106M347	Part Numbers And Schematics Guide – Blastmaster® Abrasive Blasting Pot Mufflers

PART NUMBERS AND SCHEMATICS

Blastmaster® 125P Remote Control System

Item #	Part #	Description
Fig. 7		
—	1012500	Blastmaster® 125P Remote Control System – Complete
1	1012000	Abrasive Trap – Complete (<i>see Figure 10</i>)
2	1012050	1" Outlet Valve – Complete (<i>see Figure 9</i>)
3	10CL18	Coupled Pneumatic Control Line – 18 Inches
4	10TL5	Coupled Pneumatic Control Line – 5 Feet
5	1017001	3/16" Control Line Union (<i>Two Required</i>)
6	10TL50	Coupled Pneumatic Control Line – 50 Feet
	10TL100	Coupled Pneumatic Control Line – 100 Feet (<i>optional</i>)
7	1015000	Blastmaster® 150P Remote Control Switch – Complete
8	1012200	1-1/2" Inlet Valve – Complete (<i>see Figure 8</i>)
—	1011501	1-1/2" NPT (M) x 1-1/4" NPT (F) Bushing (<i>Not Shown</i>)

PART NUMBERS AND SCHEMATICS

Figure 7: Blastmaster® 125P Remote Control System

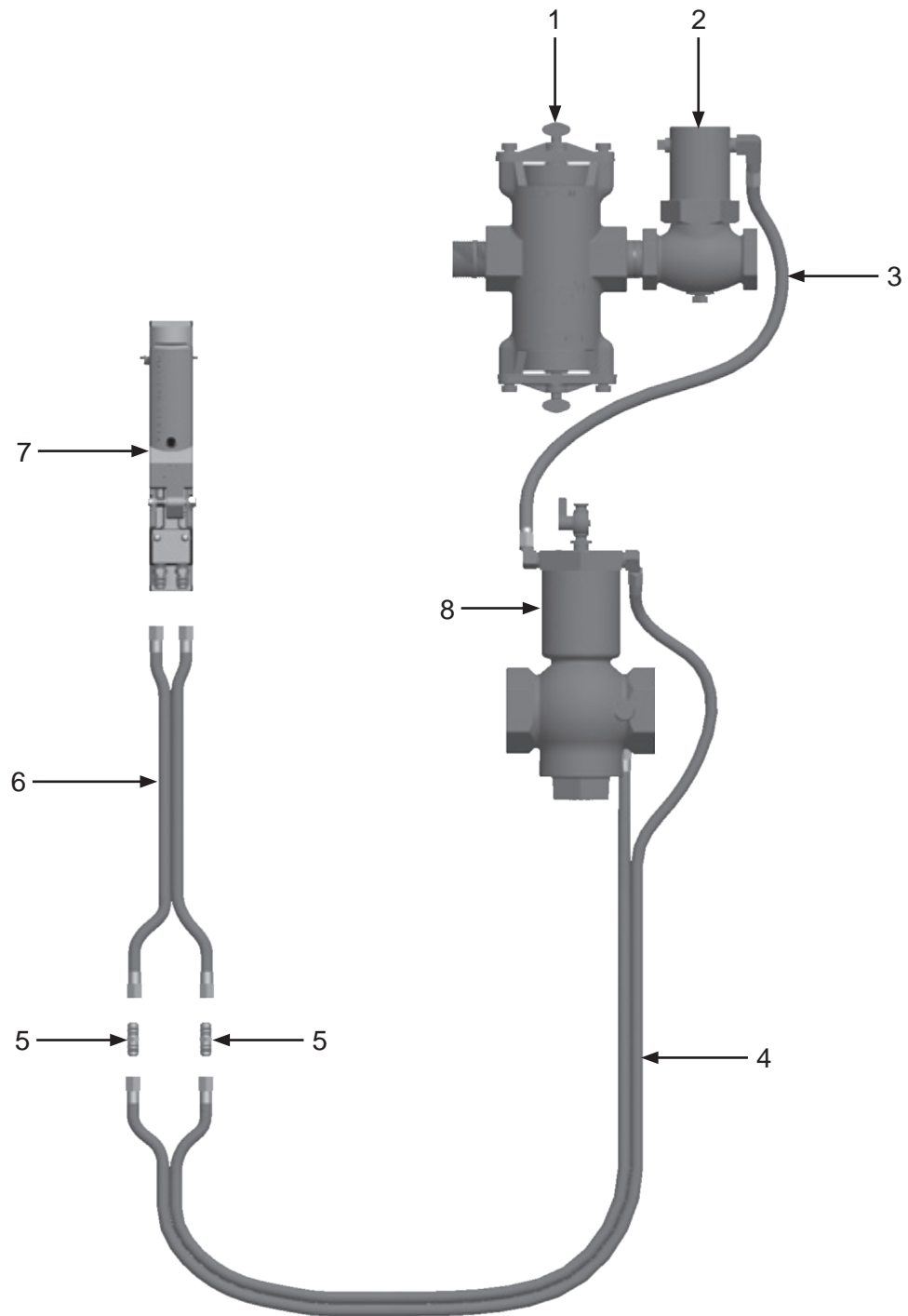

PART NUMBERS AND SCHEMATICS

Figure 8: 1-1/2" Inlet Valve

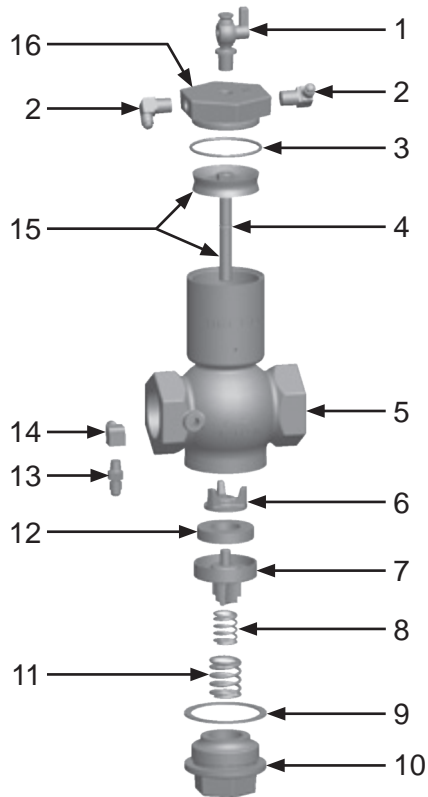

Item #	Part #	Description
Fig. 8		
—	1012200	1-1/2" Inlet Valve – Complete
1	1012101	1/4" NPT Petcock
2	1012051	1/4" NPT Brass Elbow (<i>Two Required</i>)
3	1012213	1/8" x 2-1/2" O-ring
4	1012208	1/16" x 7/16" O-ring
5	1012204	1-1/2" Body
6	1012207	1-1/2" Plug Washer Retainer
7	1012205	1-1/2" Plug
8	1012105	5/8" x 1-11/16" Inner Spring
9	1012202	1-1/2" Bottom Cap Gasket
10	1012201	1-1/2" Bottom Cap
11	1012203	7/8" x 2-1/16" Outer Spring
12	1012206	1-1/2" Plug Washer
13	1012103	1/8" Adapter with 1/16" Restrictor Port
14	1012113	1/8" Street Elbow
15	1012209	Piston and Rod Assembly
16	1012214	1-1/2" Cylinder Cap
—	1012215	1-1/2" Inlet Valve Repair Kit (Includes Item #'s: 3,4,8,9,11, and 12 (Quantity of Two))

PART NUMBERS AND SCHEMATICS

Figure 9: 1" Outlet Valve

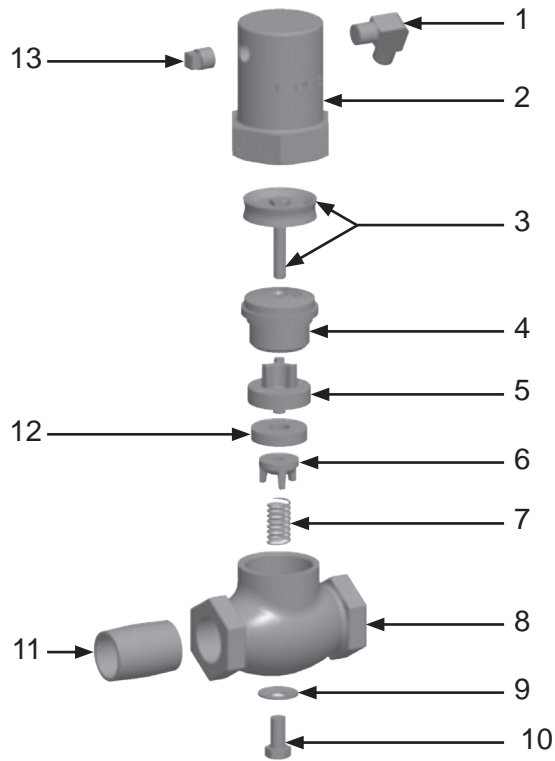

Item #	Part #	Description
Fig. 9		
—	1012050	1" Outlet Valve – Complete
1	1012051	1/4" x 1/4" Brass Elbow
2	1012053	Bonnet
3	1012054	Piston and Rod Assembly
4	1012058	Plug and Spindle Guide
5	1012059	Plug
6	1012061	Plug Washer Retainer
7	1012063	7/16" x 1-5/8" Spring
8	1012062	Body
9	1012064	3/8" Nylon Washer
10	1012065	3/8" x 3/4" Bolt
11	1012151	1" NPT Close Nipple
12	1012060	Plug Washer
13	1012052	1/4" NPT Pipe Plug
—	1012066	1" Outlet Valve Repair Kit (Includes Item #'s: 5,6,7,9,10, and 12 (Quantity of Two))

PART NUMBERS AND SCHEMATICS

Figure 10: Abrasive Trap

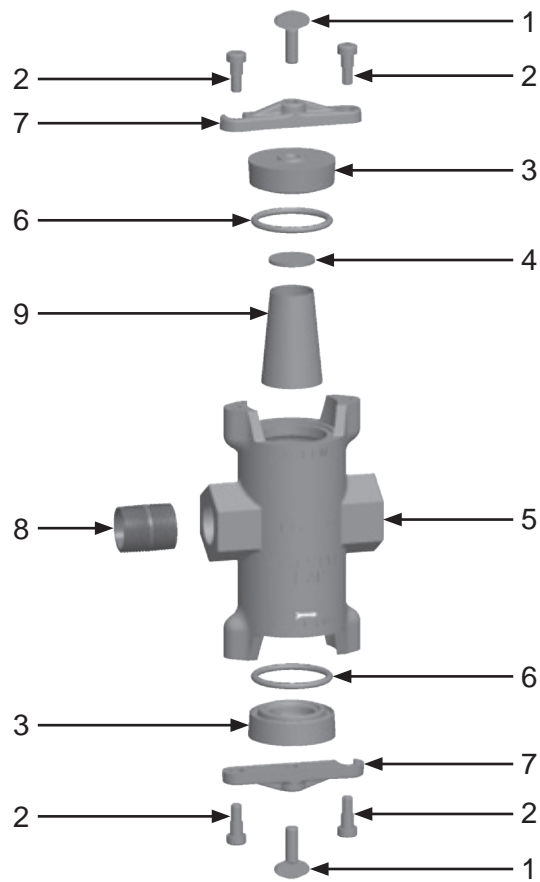

Item #	Part #	Description
Fig. 10		
—	1012000	Abrasive Trap – Complete
1	1012006	Thumb Screw (<i>Two Required</i>)
2	1012007	3/8" x 3/8" Shoulder Bolt (<i>Four Required</i>)
3	1012003	Abrasive Trap Cap (<i>Two Required</i>)
4	1012008	Abrasive Trap Screen Gasket
5	1012004	Abrasive Trap Body
6	1012002	Abrasive Trap O-ring (<i>Two Required</i>)
7	1012005	Cap Lock Bar (<i>Two Required</i>)
8	1012151	1" NPT Close Nipple
9	1012001	Abrasive Trap Screen
—	1012009	Abrasive Trap Repair Kit (Includes Item #'s: 4,6 (<i>Quantity of Two</i>), and 9 (<i>Quantity of Three</i>))

PART NUMBERS AND SCHEMATICS

Figure 11: 120-Volt AC to 12-Volt AC Power Converter

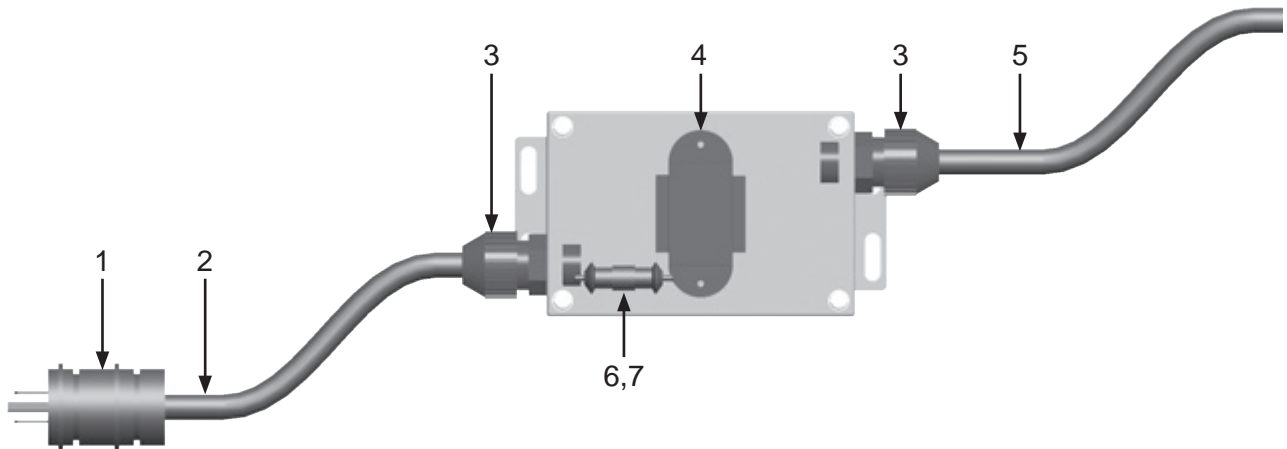

Item #	Part #	Description
Fig. 11		
—	1030020	Marco 120-Volt AC to 12-Volt AC Power Converter – Complete
1	1030026	3-prong, 120-Volt AC Plug – Male
2	1015550	14/3 SEOW Power Cord (<i>Per Foot</i>)
3	1030025	Strain Relief (<i>Two Required</i>)
4	1030022	Transformer – Marco 120-Volt AC to 12-Volt AC Power Converter
5	1030013	14/2 SEOW Power Cord (<i>Per Foot</i>)
6	1030024	2 Amp Fuse
7	1030023	In-Line Fuse Holder
—	1030021	Resistor (<i>Not Shown</i>)
—	1091063	Marco 120-Volt AC to 12-Volt AC Power Converter Hazard Identification Label
—	1091067	Power-Out Decal (<i>Not Shown</i>)
—	1092014	Power-In Decal (<i>Not Shown</i>)

PART NUMBERS AND SCHEMATICS

12-Volt DC Blastmaster® 125E Remote Control System

Item #	Part #	Description
Fig. 12		
—	1012551	12-Volt DC Blastmaster® 125E Remote Control System – Complete
1	1012326	1/4" NPT 90° Swivel Fitting
2	1017019	1/4" X 1/4" Hex Nipple
3	10WS	Watts Strainer
4	1012051	1/4" NPT Brass Elbow <i>(Two Required)</i>
5	1012000	Abrasive Trap – Complete <i>(see Figure 10)</i>
6	1012050	1" Outlet Valve – Complete <i>(see Figure 9)</i>
7	1011501	1-1/2" NPT (M) x 1-1/4" NPT (F) Bushing
8	10TL5	Coupled Pneumatic Twinline Hose – 5 Feet
9	1012200	1-1/2" Inlet Valve – Complete <i>(see Figure 8)</i>
10	10CL18	Coupled Pneumatic Control Line – 18 inches
11	1015542	50 Feet of Electric Control Line with Male and Female Twist-Lock Plugs <i>(Includes Item #'s: 12, 13, and 14 (Quantity of 50 Feet))</i>
12	1015551	2-prong Twist-Lock Plug – Male
13	1015552	2-prong Twist-Lock Plug – Female
14	1015540	16/2 Power Cord – per foot
15	1015600	Blastmaster® 156E Remote Control Switch – Complete
16	1030718	Battery Clamps (pair)
17	1015541	Battery Clamp Kit <i>(Includes Item #'s: 13, 14 (Quantity of Two Feet), and 16)</i>
18	1015543	25 Feet of Electric Control Line with Male and Female Twist-Lock Plugs <i>(Includes Item #'s: 12, 13, and 14 (Quantity of 25 Feet))</i>
19	1019001	12-Volt DC 190 Electric Control Assembly <i>(See Figure 11)</i>

PART NUMBERS AND SCHEMATICS

Figure 12: 12-Volt DC Blastmaster® 125E Remote Control System

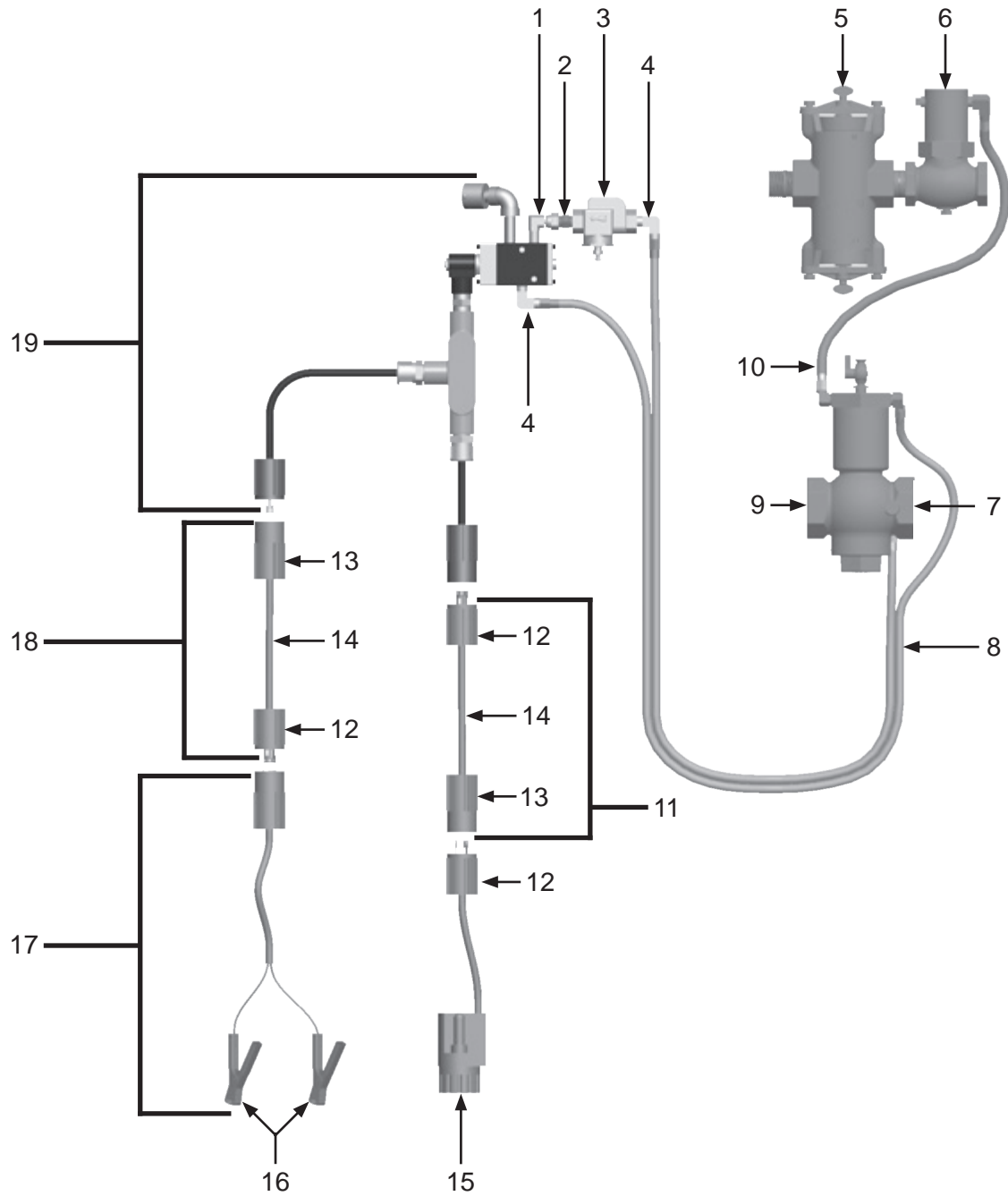

PART NUMBERS AND SCHEMATICS

Figure 13: 12-Volt DC 190 Electric Control Assembly

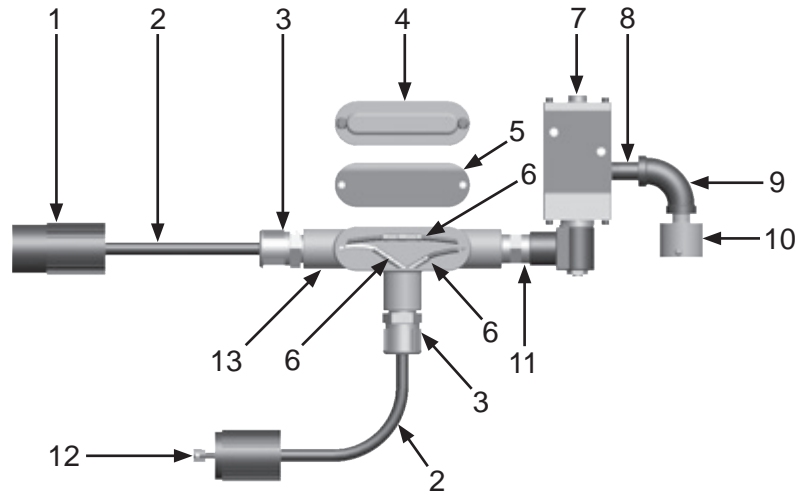

Item #	Part #	Description
Fig. 13		
—	1019001	12-Volt DC 190 Electric Control Assembly – Complete
1	1015552	2-prong Twist-Lock Plug – Female
2	1015540	16/2 Electric Cord – per foot
3	1019021	Cord Grip (<i>Two Required</i>)
4	1019022	Conduit Box Cover
5	1019023	Conduit Box Cover Gasket
6	1030028	Butt Splicer
7	1019010	12-Volt DC Electric Solenoid – Complete (<i>see Figure 14</i>)
8	1011217	1/4" x 2" Pipe Nipple
9	1011832	1/4" NPT 90° Pipe Nipple
10	10DE025	Dust Eliminator
11	20100677	1/2" x 1/2" NPT Hex Nipple
12	1015551	2-prong Twist-Lock Plug – Male
13	1090020	1/2" Tee Conduit Box

PART NUMBERS AND SCHEMATICS

Figure 14: 12-Volt DC 190 Electric Solenoid

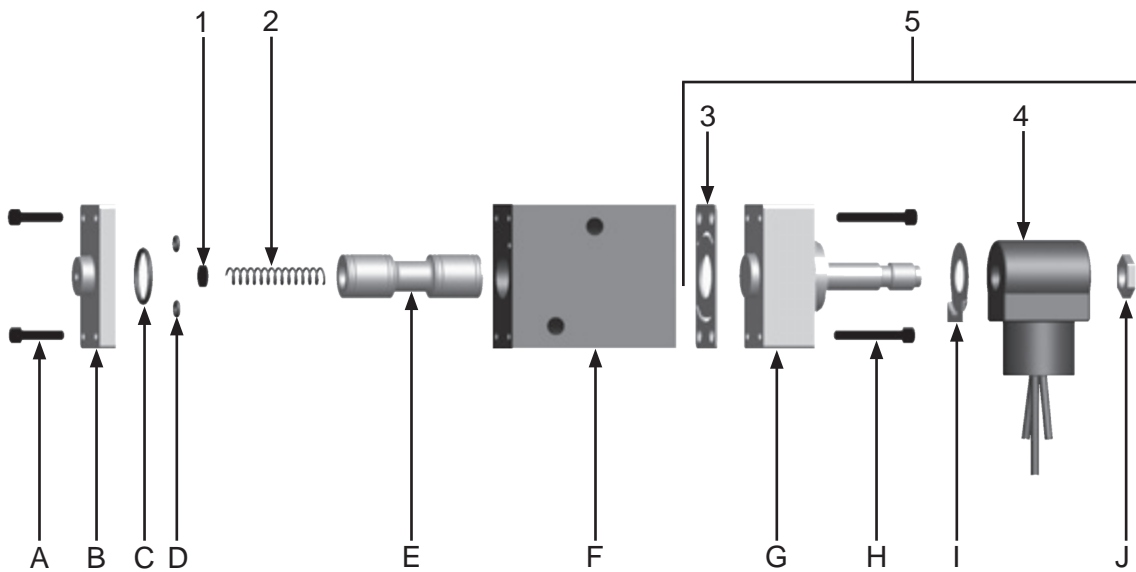

Item #	Part #	Description
--------	--------	-------------

Fig. 14

—	1019010	12-Volt DC 190 Electric Solenoid – Complete
---	----------------	--

1	1019029	Felt Filter
---	---------	-------------

2	1019032	Spring
---	---------	--------

3	1019033	Gasket
---	---------	--------

4	1019039	12-Volt DC Coil
---	---------	-----------------

5	1019034	12-Volt DC Operator Assembly (Includes Items: #3, #4, G, H, I, and J)
---	---------	--

—	1019030	Electric Solenoid Repair Kit (Includes Items: #1, #2, #3, C, D, and E)
---	---------	---

* Items A–J are not available individually

PART NUMBERS AND SCHEMATICS

120-Volt AC Blastmaster® 125E Remote Control System

Item #	Part #	Description
Fig. 15		
—	1012552	120-Volt AC Blastmaster® 125E Remote Control System – Complete
1	1012326	1/4" NPT 90° Swivel Fitting
2	1017019	1/4" X 1/4" Hex Nipple
3	10WS	Watts Strainer
4	1012051	1/4" NPT Brass Elbow <i>(Two Required)</i>
5	1012000	Abrasive Trap – Complete <i>(see Figure 10)</i>
6	1012050	1" Outlet Valve – Complete <i>(see Figure 9)</i>
7	1011501	1-1/2" NPT (M) x 1-1/4" NPT (F) Bushing
8	10TL5	Coupled Pneumatic Control Line – 5 Feet
9	1012200	1-1/2" Inlet Valve – Complete <i>(see Figure 8)</i>
10	10CL18	Coupled Pneumatic Control Line – 18 inches
11	1015542	50 Feet of Electric Control Line with Male and Female Twist-Lock Plugs <i>(Includes Item #'s: 12, 13, and 14 (Quantity of 50 Feet))</i>
12	1015551	2-prong Twist-Lock Plug – Male
13	1015552	2-prong Twist-Lock Plug – Female
14	1015540	16/2 Power Cord – per foot
15	1015600	Blastmaster® 156E Remote Control Switch – Complete
16	1030020	Marco 120-Volt AC to 12-Volt AC Power Converter <i>(see Figure 11)</i>
17	1019002	12-Volt AC 190 Electric Control Assembly <i>(see Figure 17)</i>

PART NUMBERS AND SCHEMATICS

Figure 15: 120-Volt AC Blastmaster® 125E Remote Control System

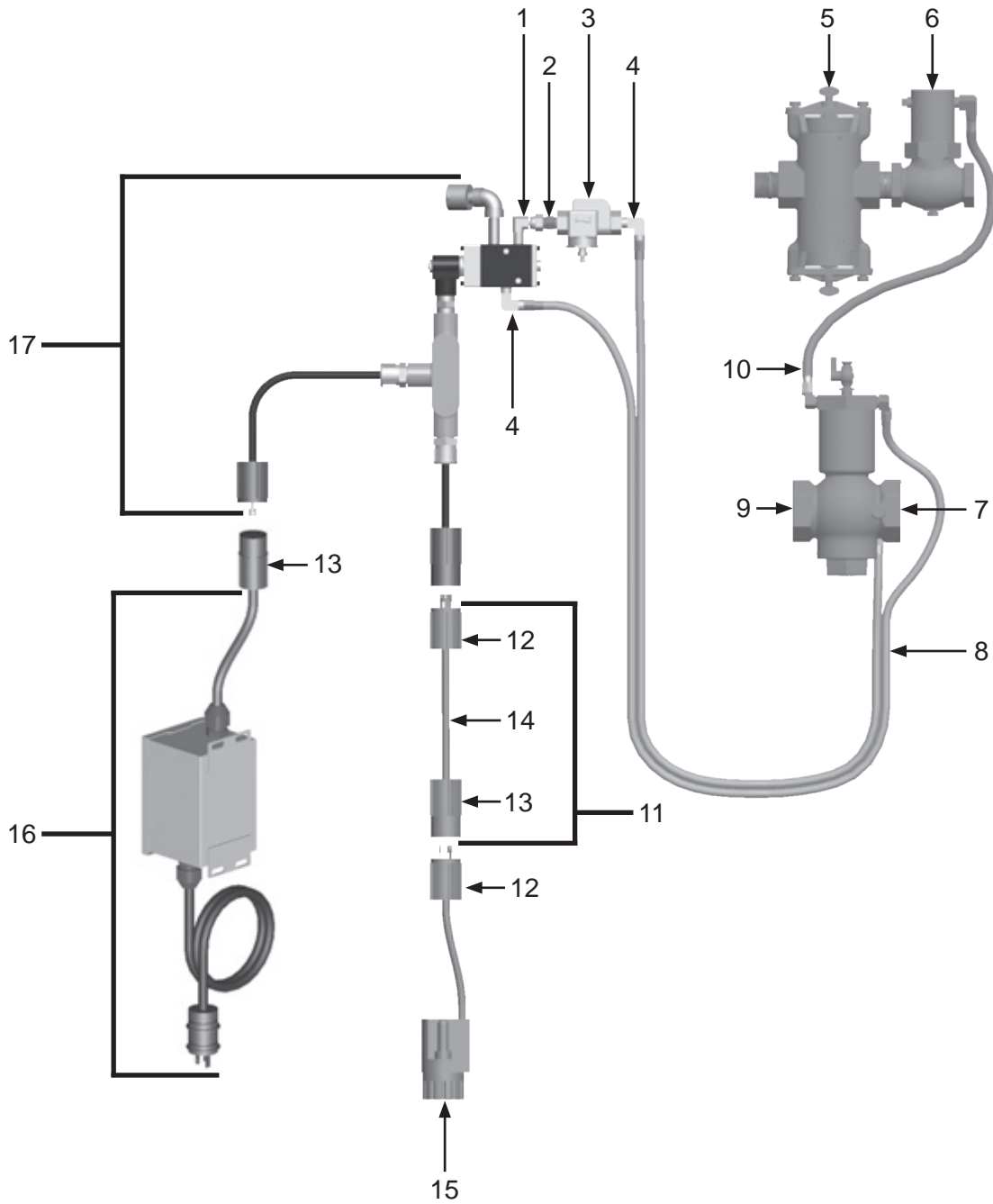

PART NUMBERS AND SCHEMATICS

Figure 16: 12-Volt AC 190 Electric Control Assembly

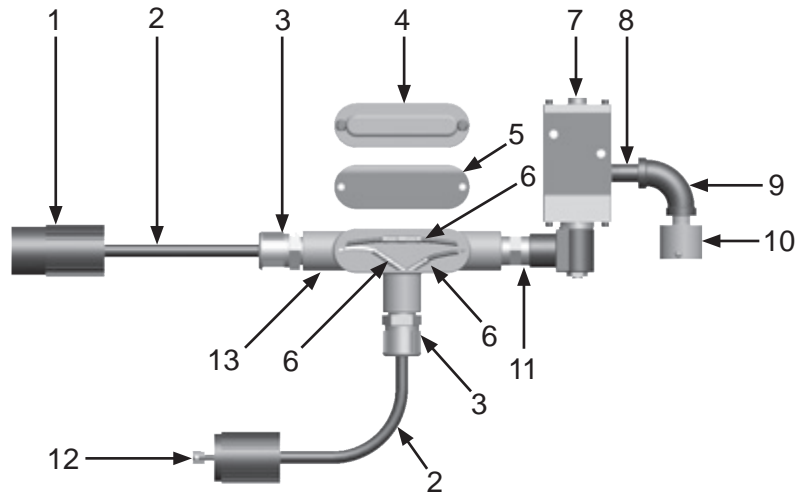

Item #	Part #	Description
Fig. 16		
—	1019002	12-Volt AC 190 Electric Control Assembly – Complete
1	1015552	2-prong Twist-Lock Plug – Female
2	1015540	16/2 Power Cord – per foot
3	1019021	Cord Grip (<i>Two Required</i>)
4	1019022	Conduit Box Cover
5	1019023	Conduit Box Cover Gasket
6	1030028	Butt Splicer
7	1019011	12-Volt AC Electric Solenoid – Complete (<i>see Figure 17</i>)
8	1011217	1/4" x 2" Pipe Nipple
9	1011832	1/4" NPT 90° Pipe Nipple
10	10DE025	Dust Eliminator
11	20100677	1/2" x 1/2" NPT Hex Nipple
12	1015551	2-prong Twist-Lock Plug – Male
13	1090020	1/2" Tee Conduit Box

PART NUMBERS AND SCHEMATICS

Figure 17: 12-Volt AC 190 Electric Solenoid

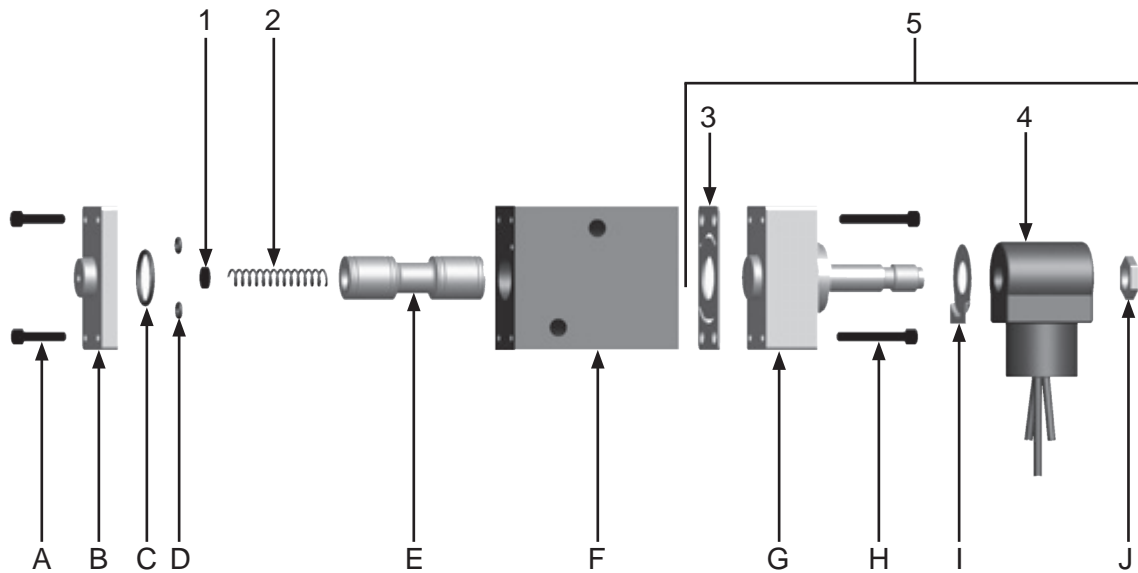

Item #	Part #	Description
--------	--------	-------------

Fig. 17

—	1019011	12-Volt AC 190 Electric Solenoid – Complete
---	----------------	--

1	1019029	Felt Filter
---	---------	-------------

2	1019032	Spring
---	---------	--------

3	1019033	Gasket
---	---------	--------

4	1019040	12-Volt AC Coil
---	---------	-----------------

5	1019035	12-Volt AC Electric Operator Assembly (Includes Items: #3, #4, G, H, I, and J)
---	---------	---

—	1019030	12-Volt AC Electric Solenoid Repair Kit (Includes Items: #1, #2, #3, C, D, and E)
---	---------	--

* Items A–J are not available individually

PART NUMBERS AND SCHEMATICS

Blastmaster® Regulator Abrasive Metering Valve

Item # Part #

Item #	Part #	Description
Fig. 18		
—	1014000	Blastmaster® Regulator Abrasive Metering Valve – Complete
1	1014022	1/2" Hex Nut (<i>Eight Required</i>)
2	1014001	Upper Body
3	1014004	Body Gasket (<i>Two Required</i>)
4	1014003	Valve Core
5	1014005	Stainless Disc
6	1014012	Shaft Gasket
7	1014002	Lower Body
8	1014021	1/2" x 1-3/4" Hex Bolt (<i>Four Required</i>)
9	1014023	Packing Rope
10	1014011	Packing Gland
11	1012105	Spring (1-11/16" Long)
12	1014006	Heavy-Duty Handle
13	1014026	Pin
14	1014025	Pin Clip
15	1014024	1-1/4" "Y" Fitting
16	1011207	1-1/4" x 4" Nipple
17	1014010	Stud (<i>Two Required</i>)
18	1014016	1/4" Wing Nut
19	1014017	1/4" Flat Washer
20	1014008	Spacer
21	1012154	1/4" x 1" Hex Bolt
22	1014018	1/4" x 1/2" Set Screw (<i>Two Required</i>)
23	1014007	Gauge
24	1012112	2" O.D. x 1/8" O-ring
25	1014013	Inspection Plate
26	1014020	5/16" Wing Nut (<i>Two Required</i>)
27	1014019	5/16" x 1-1/4" Bolt (<i>Two Required</i>)
28	1014015	1-1/2" NPT Close Nipple
—	105M021	Features, Advantages, and Benefits Guide – Blastmaster® Regulator Abrasive Metering Valve
—	106M021	Part Numbers and Schematics Guide – Blastmaster® Regulator Abrasive Metering Valve
—	1090021	Operator's Manual – Blastmaster® Regulator Abrasive Metering Valve
—	1091045	Hazard Identification Tag

PART NUMBERS AND SCHEMATICS

Figure 18: Blastmaster® Regulator Abrasive Metering Valve

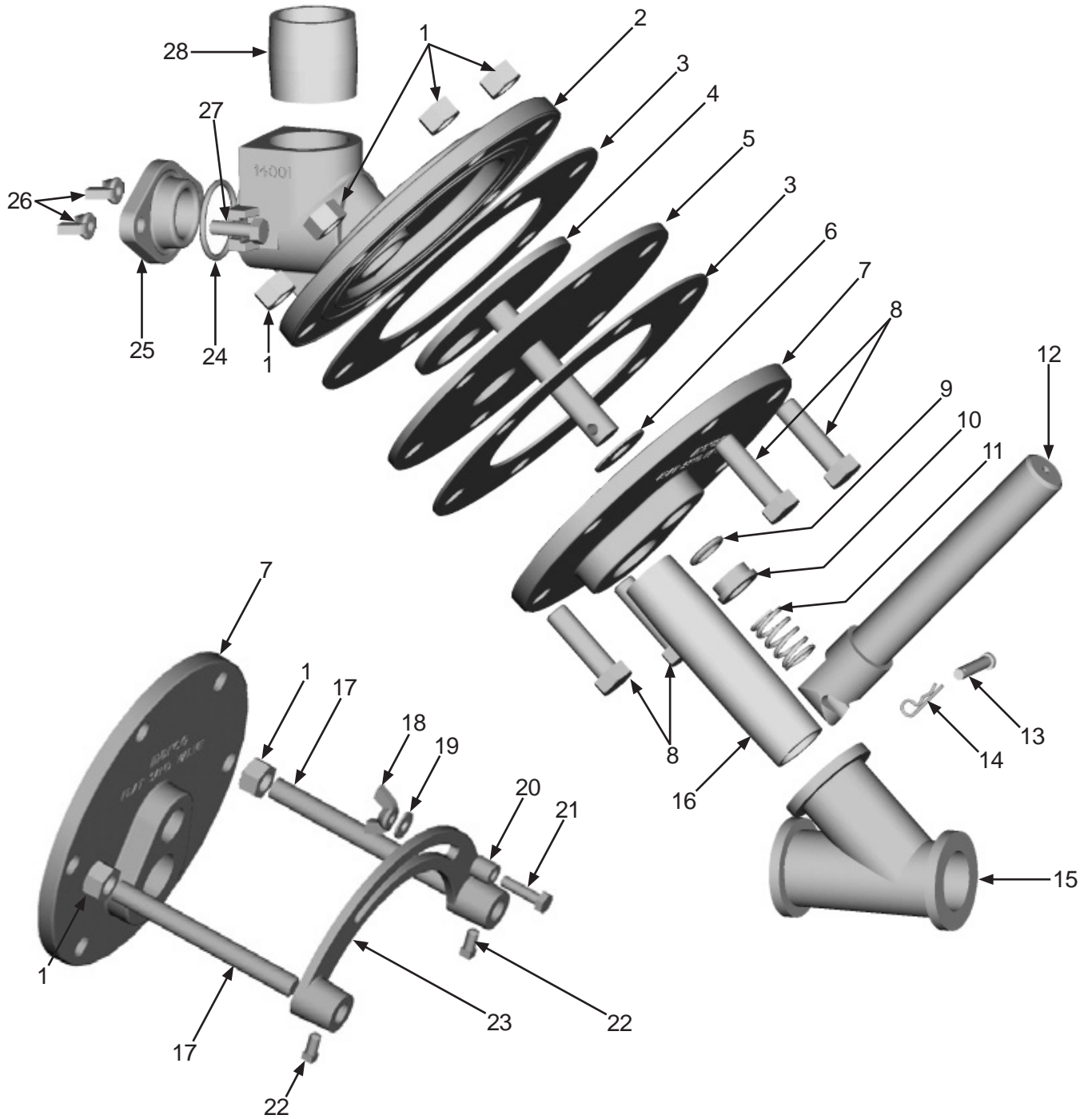

OPTIONAL ACCESSORIES

Figure 19: 1-1/2" Extractor Abrasive Blasting Pot Moisture Separator

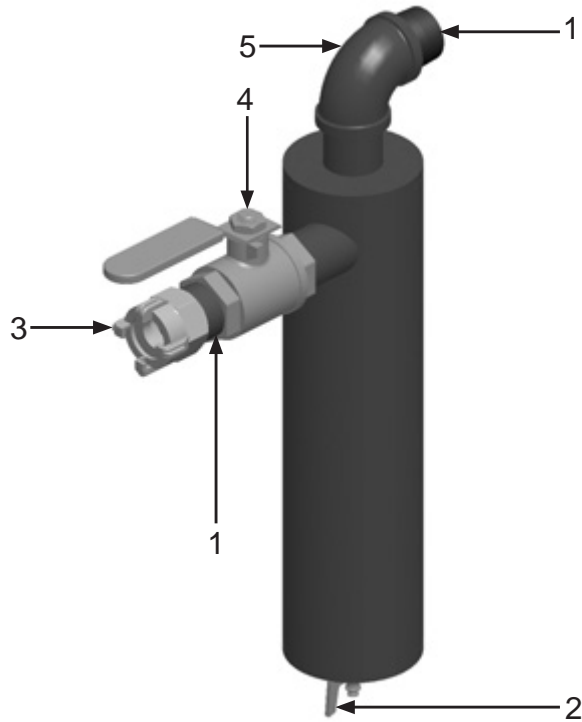

Item #	Part #	Description
Fig. 19		
—	10101313	1-1/2" Extractor Abrasive Blasting Pot Moisture Separator
1	1014015	1-1/2" NPT Close Nipple (<i>Two Required</i>)
2	1012101	1/4" NPT Brass Petcock
3	10ME4	1-1/2" (F) 4-Lug Air Hose Coupling
4	1011603	1-1/2" NPT Full Port Brass Ball Valve
5	1011842	1-1/2" 90° Galvanized Elbow
—	105M349	Features and Specifications Guide – Extractor Moisture Separators
—	106M349	Part Numbers and Schematics Guide – Extractor Moisture Separators

OPTIONAL ACCESSORIES

Figure 20: Lid and Screen

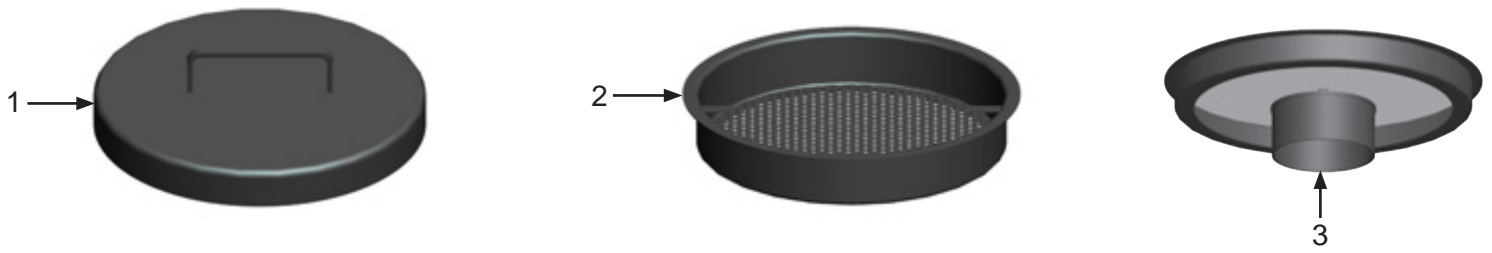

Item #	Part #	Description
--------	--------	-------------

Fig. 20

1	1006101	24" Lid
2	1006102	24" Screen
3	10100733	Abrasive Umbrella (<i>Screen Not Included</i>)

OPTIONAL ACCESSORIES

Figure 21: Loading Skid

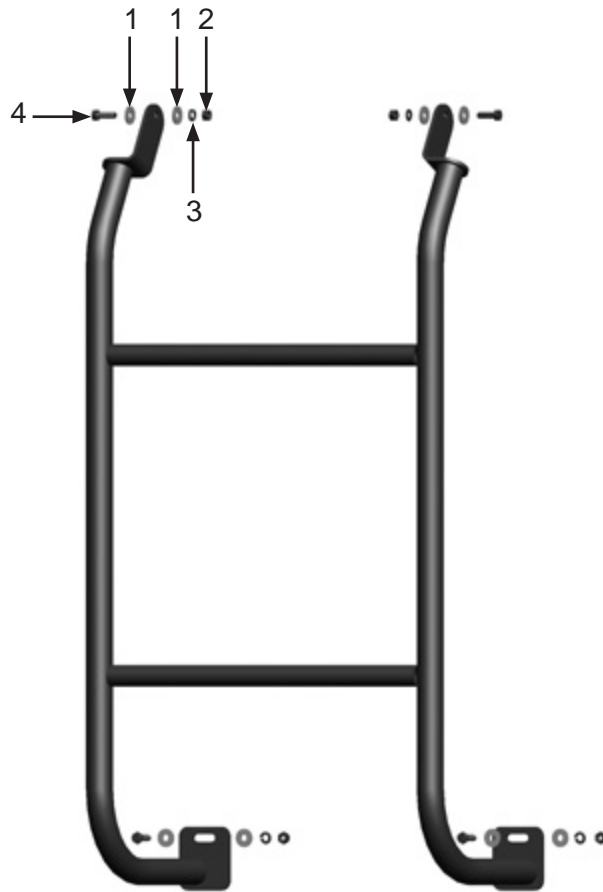

Item #	Part #	Description
--------	--------	-------------

Fig. 21

—	1065040	Load Skid for Blastmaster® 6.0 and 6.5 Cu. Ft. Abrasive Blasting Pots – Complete
1	10L805003	5/16" Zinc Flat Washer
2	1035046	5/16-18 Nut
3	10L805014	5/16" Lock Washer
4	1035045	5/16-18 x 1" Bolt

GLOBAL HEADQUARTERS

- 3425 East Locust Street
Davenport, IA 52803

ph: 800.BLAST.IT (800.252.7848)
ph: 563.324.2519
fax: 563.324.6258

REGIONAL BRANCH OFFICES

- **Iowa**
Davenport
- **Louisiana**
Gonzales
Harvey
Lafayette
- **Ohio**
Youngstown
- **Texas**
Beaumont
Corpus Christi
Deer Park



ABRASIVES
BLASTING
COATING
DUST COLLECTORS
ENGINEERED SYSTEMS
RENTAL
SAFETY
SERVICE & REPAIR
VACUUMS

40+ NATIONWIDE SHIPPING LOCATIONS



★ Marco Regional Branch Offices and Shipping Locations ● Direct Shipping Locations

CONTACT MARCO

800.BLAST.IT
(800.252.7848)
563.324.2519
FAX: 563.324.6258

WWW.MARCO.US
SALES@MARCO.US