

OPERATOR'S MANUAL

BLASTMASTER® 6.0 CU. FT. C-SERIES ABRASIVE BLASTING POT

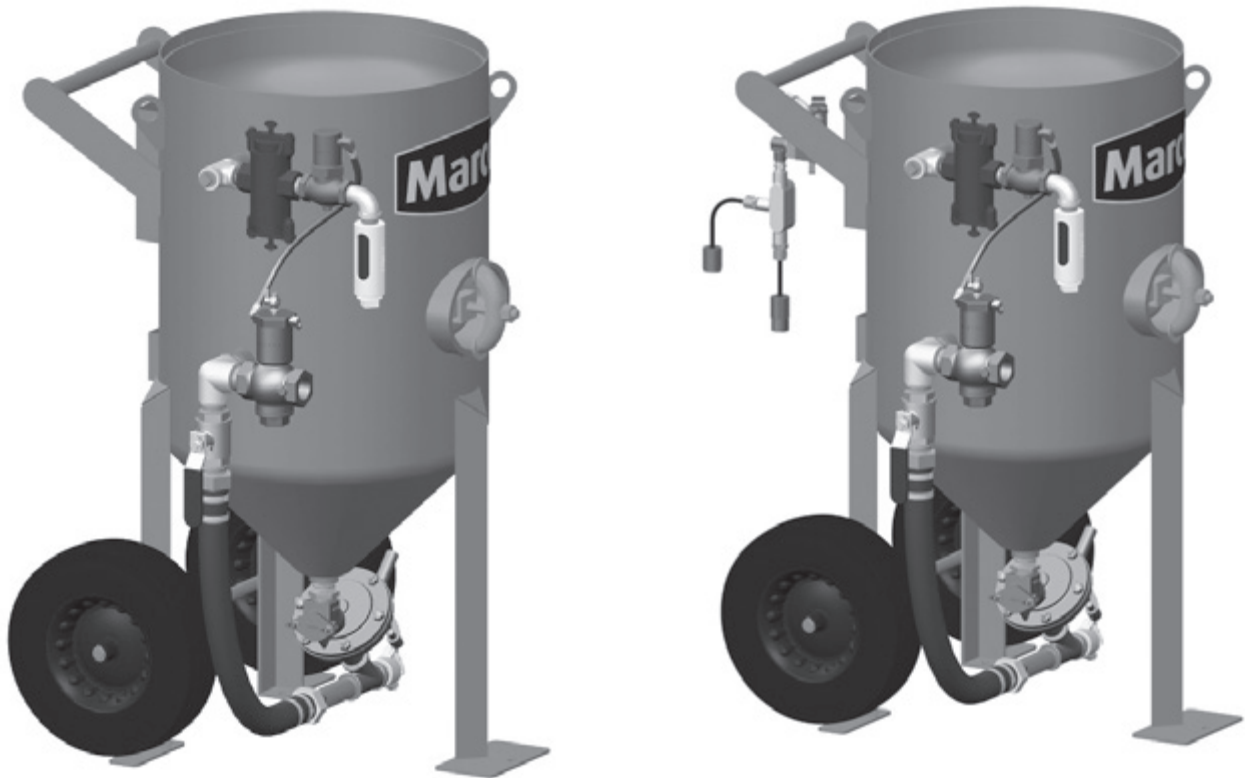

**BUILT MARCO
TOUGH**
MARCO MANUFACTURED

⚠ WARNING

Before using this equipment, read, understand and follow all instructions in the Operator's Manuals provided with this equipment. If the user and/or assistants cannot read or understand the warnings and instructions, the employer of the user and/or assistants must provide adequate and necessary training to ensure proper operation and compliance with all safety procedures pertaining to this equipment. If Operator's Manuals have been lost, please visit www.marco.us, or contact Marco at 563.324.2519 for replacements. Failure to comply with the above warning could result in death or serious injury.

Marco®

Company Profile

Since 1944, Marco has developed a strong tradition of providing innovative and reliable products and services to the surface preparation and protective coatings industries. We are the world's premier provider of Abrasives, Blasting Equipment, Coating Equipment, Engineered Systems, Rental Equipment, Safety Equipment, Service, and Repair.

Through innovative designs and a total commitment to quality, Marco manufactures products that increase production rates, create a safer workplace, and reduce maintenance costs. Marco's industry experience, manufacturing capabilities, legendary customer service, product availability, logistics services, and technology leadership is your assurance that we deliver high quality products and services, providing the best value to you, our customer.

The Marco Difference

- **Industry Experience** – With Marco on your team, you have access to expertise which can only come from decades of industry leadership. We have organized our engineering department, production specialists, customer operations, and safety support into a “Center of Competence.” As a Marco customer, you have access to hundreds of years of cumulative experience related to your operations.
- **Manufacturing Excellence** – Marco is a U.S. based, ISO 9001:2008 certified manufacturer of equipment for the Surface Preparation and Protective Coatings industries. Marco's engineers benchmark the industry to ensure that we design and manufacture superior products that set the “Gold Standard” for performance, safety, and quality.
- **Legendary Customer Service** – Marco's legendary customer service team is staffed by friendly, highly-trained individuals who are focused on providing the highest level of product support, order accuracy, and customer satisfaction.
- **Product Availability** – We stock over 10,000 SKU's and have over 45 shipping locations to serve North American and International markets for all major brands of blasting and painting equipment. As the largest provider of surface preparation and protective coatings equipment in the world, our inventory levels and product availability are unmatched.
- **Logistics Services** – Marco's in-house logistics team is dedicated to moving your shipment anywhere in the world. We move over 14,000 truckloads every year, allowing you to save on freight costs by leveraging our buying power. Lower your process costs with a single invoice, which includes product and freight.
- **Technology Leadership** – Our website provides: Operator's Manuals, Part Numbers and Schematics Guides, MSDS information, and Features and Specifications Guides, providing access to information 24/7. Our Extranet application allows you to receive quotes and place orders online. Our Intranet maintains a complete record of your purchase history to assist with ongoing support of your existing equipment and future purchasing decisions.

Vision Statement

Marco is the world's premier provider of Abrasives, Blasting Equipment, Coating Equipment, Engineered Systems, Rental Equipment, Safety Equipment, Service, and Repair.

Mission Statement

Marco provides strong leadership and innovation to the surface preparation and protective coatings industries. We dedicate our efforts to the continuous improvement of our products, services, processes, people, and most importantly, the quality of our customer's experience.

Quality Statement

Marco is committed to providing superior quality in the design, manufacturing, distribution, rental, service, and repair of our products. Our ISO 9001:2008 certification extends throughout all operations in all locations. Continuous improvement of our processes and supply chain Integration comprise the core of our business strategy for delivering exceptional quality and value in all Marco products and services.

Management Philosophy

We are a company dedicated to the success of every customer and associate. We discuss, debate, challenge, measure, and test our ideas. We will be boundless and limitless in our passion to improve. Through sound leadership and dedicated associates, we will ensure a long term, profitable future for Marco, our associates, customers, and suppliers.

TABLE OF CONTENTS

Company Profile	1	Remove & Install Inlet Valve	17
Definition of Terms	2	Remove & Install Outlet Valve	18
Hazard Identifications	3	Remove & Install Abrasive Trap	19
Air & Abrasive Consumption Chart	6	Remove & Install Abrasive Metering Valve	20
Daily Pre-Operation Checklist	8	Disassemble and Assemble 1-1/2" Inlet Valve	21
Operating Instructions	9	Disassemble and Assemble 1" Outlet Valve	23
Description	9	Disassemble and Assemble Abrasive Trap	25
Operational Requirements	9	Disassemble and Assemble Blastmaster® Regulator Abrasive Metering Valve	27
Initial Setup	9	Maintenance Schedules Quick Reference Charts	29
Operating Instructions	11	Troubleshooting	30
Blast Hoses and Connections	13	Limited Warranty	34
Specifications	14	Disclaimer of Warranty	34
Maintenance	15	Exclusive Remedy for Warranty Claims	34
Remove & Install Inspection Door Assembly	15	Limitation of Remedies	34
Remove & Install Pop-up Valve	16		

DEFINITION OF TERMS

DANGER

This is an example of danger. This indicates an imminently hazardous situation which, if not avoided, will result in death or serious injury.

CAUTION

This is an example of a caution. This indicates a potentially hazardous situation which, if not avoided, may result in minor or moderate injury. It can also be used to alert against unsafe practices.

WARNING

This is an example of a warning. This indicates a potentially hazardous situation which, if not avoided, could result in death or serious injury.

NOTICE

This is an example of a notice. This indicates policy or practice directly related to safety of personnel or protection of property.

HAZARD IDENTIFICATIONS

WARNING

Failure to comply with ANY WARNING listed below could result in death or serious injury.

- ▶ OSHA sets exposure limits to protect workers from exposure to respirable crystalline silica, 29 CFR 1910.1053. Airborne dust could increase the exposure levels beyond permissible limits. Breathing dust containing silica could cause silicosis, a fatal lung disease. Breathing dust during abrasive blasting operations, post-blast cleaning operations, and/or servicing equipment within the abrasive blasting area may expose an individual to conditions that could cause asbestosis, lead poisoning and/or other serious or fatal diseases. Harmful dust containing toxic material from abrasives or surfaces being abrasive blasted can remain suspended in the air for long periods of time after abrasive blasting has ceased. A NIOSH-approved, well-maintained, respirator designed for the specific operation being performed must be used by anyone abrasive blasting, handling or using the abrasive, and anyone in the area of the dust.
- ▶ Contact NIOSH and OSHA offices to determine the proper respirator for your specific application. The air supplied to the respirator must be at least Grade D quality as described in Compressed Gas Association Commodity Specification G-7.1 and as specified by OSHA Regulation 1910.134. Ensure air filter and respirator system hoses are not connected to non-air sources or in-plant lines that may contain nitrogen, oxygen, acetylene or other non-breathable gases. Before removing respirator, use an air monitoring instrument to determine if the atmosphere is safe to breathe.
- ▶ You must comply with all OSHA, local, City, State, Province, Country and jurisdiction regulations, ordinances and standards, related to your particular work area and environment. Keep unprotected individuals out of the work area.
- ▶ Abrasive blasting operators must receive thorough training on the use of abrasive resistant attire which includes: supplied-air respirator, abrasive blasting suit, safety shoes, gloves, ear protection and eye protection. Protect the operator and bystanders by complying with NIOSH and OSHA Safety Standards.
- ▶ Inspect all equipment for wear or damage before and after each use. Failure to use Original Equipment Manufacturer repair parts and failure to immediately replace worn or damaged components could void warranties and cause malfunctions.
- ▶ OSHA requires abrasive blasting nozzles be equipped with an operating valve, which shall be designed to be held open only by continuous hand pressure and shall close immediately upon release of hand pressure (i.e., a “deadman” control). The valve shall not be modified in any manner that would allow it to remain open without the application of continuous hand pressure by the operator. Failure to comply with the above warning could result in release of high speed abrasive and compressed air resulting in death or serious injury. OSHA 29CFR 1910.244(b)
- ▶ Point the abrasive blasting nozzle only at the surface being abrasive blasted. Never point the abrasive blasting nozzle or abrasive stream at yourself or others.
- ▶ Unless otherwise specified, maximum working pressure of abrasive blasting pots and related components must not exceed 150 psi. Exceeding maximum working pressure of 150 psi could cause the abrasive blasting pot and components to burst. Failure to comply with the above warning could result in death or serious injury.
- ▶ Never weld, grind or drill on the abrasive blasting pot (or any pressure vessel). Doing so will void ASME certification and manufacturer’s warranty. Welding, grinding or drilling on the abrasive blasting pot (or any pressure vessel) could weaken the vessel causing it to burst. Failure to comply with the above warning could result in death or serious injury. (ASME Pressure Vessel Code, Section VIII, Division 1)
- ▶ This equipment is not intended for use in any area that might be considered a hazardous location, as described in the National Electric Code NFPA 70, Article 500. Use of this equipment in a hazardous location could cause an explosion or electrocution.
- ▶ Never attempt to move an abrasive blasting pot containing abrasive. Never attempt to manually move abrasive blasting pots greater than 6.5 cubic foot capacity. Always use at least two capable people to manually move an abrasive blasting pot on flat, smooth surfaces. A mechanical lifting device must be used if an abrasive blasting pot is moved in any other manner.

HAZARD IDENTIFICATIONS

WARNING

Failure to comply with ANY WARNING listed below could result in death or serious injury.

- ▶ This product is not for use in wet environments. Always use a Ground Fault Interrupter Circuit (GFI) for all electrical power source connections. Use of this product in wet environments could create a shock or electrocution hazard.
- ▶ Frozen moisture could cause restrictions and obstructions in pneumatic control lines. Any restriction or obstruction in the pneumatic control lines could prevent the proper activation and deactivation of the remote control system, resulting in the release of high speed abrasive and compressed air. In conditions where moisture may freeze in the control lines an antifreeze injection system approved for this application can be installed.
- ▶ Do not cut, obstruct, restrict or pinch pneumatic control lines. Doing so could prevent the proper activation and deactivation of the remote control system, resulting in the release of high speed abrasive and compressed air.
- ▶ Use of Marco remote control switches with other manufacturer's remote control systems could cause unintended activation of remote control systems resulting in the release of high speed abrasive and compressed air. Only Marco remote control switches should be used with Marco remote control systems.
- ▶ Always be certain to have secure footing when abrasive blasting. There is a recoil hazard when abrasive blasting starts that may cause user to fall and misdirect the abrasive stream at operator or bystander.
- ▶ Never use an abrasive blasting pot or attachments as a climbing device. The person could slip and fall. The abrasive blasting pot could become unstable and tip over.
- ▶ For equipment manufactured by entities other than Marco, you must consult the Original Equipment Manufacturer operator's manuals, information, training, instructions and warnings, for the proper and intended use of all equipment.
- ▶ Flammable fumes, such as solvent and paint fumes in the work area can present an ignition or explosion hazard if allowed to collect in adequate concentrations. To reduce conditions that could result in a fire or an explosion, provide adequate ventilation, eliminate all ignition or spark sources, keep the work area free of debris, store solvents and solvent contaminated rags in approved containers, follow proper grounding procedures, do not plug/unplug power cord or turn on/off power switches when flammable fumes are present, keep a working fire extinguisher or provide another fire suppression system in the work area. Cease all operations and correct condition if a spark or ignition source is identified during operation.
- ▶ Always depressurize the entire system, disconnect all power sources and lockout/tagout all components before any maintenance or troubleshooting is attempted. Failure to comply with the above warning could cause electrical shock and inadvertent activation of equipment resulting in death or serious injury.
- ▶ Moving parts can present an area where crushing, pinching, entanglement or amputation may occur. Do not place body parts or foreign objects in any area where there are moving parts.
- ▶ Surfaces of heated supply tanks, drums and/or lines as well as the adjoining plumbing may become hot during normal use. Do not touch these heated surfaces without proper protection. Deactivate and allow sufficient time for all surfaces to cool before attempting any maintenance.
- ▶ High-pressure fluid from gun, hose leaks, or ruptured components can pierce skin and can cause a serious injury that may result in amputation. Do not point gun or spray tip at anyone or at any part of the body. Keep clear of any leaks or ruptures. Depressurize the entire system before attempting cleaning, inspecting, or servicing equipment.
- ▶ Exposure to toxic fluids or fumes may occur during the normal operation of this system. Before attempting to fill, use, or service this system, read SDS's to know the specific hazards of the fluids you are using. Always use proper Personal Protective Equipment when attempting to fill, use, or service this system.
- ▶ The use of this product for any purpose other than originally intended or altered from its original design is prohibited.
- ▶ Never hang objects from the abrasive blasting pot handle. Doing so may cause the abrasive blasting pot to become unstable and tip over.

HAZARD IDENTIFICATIONS

⚠ CAUTION

Failure to comply with ANY CAUTION listed below may result in minor or moderate injury.

- ▶ Static electricity can be generated by abrasive moving through the abrasive blasting hose causing a shock hazard. Prior to use, ground the abrasive blasting pot and abrasive blasting nozzle to dissipate static electricity.
- ▶ High decibel noise levels are generated during the abrasive blasting process which may cause loss of hearing. Ensure appropriate Personal Protective Equipment and hearing protection is in use.

NOTICE

Failure to comply with ANY NOTICE listed below could pose a hazard to personnel or property.

- ▶ See Air & Abrasive Consumption Chart for estimated abrasive consumption rates and required air flow (cubic feet per minute). Your system must meet these minimum requirements to ensure proper function and performance.
- ▶ Always use abrasive that is dry and properly screened. This will reduce the potential for obstructions to enter the remote control system, abrasive metering valve and abrasive blasting nozzle.
- ▶ Moisture build-up occurs when air is compressed. Any moisture within the abrasive blasting system will cause abrasive to clump, clogging metering valves, hoses and nozzles. Install an appropriately sized moisture separator at the inlet of the abrasive blasting system. Leave the moisture separator petcock slightly open to allow for constant release of water. If insufficient volume of air exists and petcock is unable to be left open (at all times) petcock should be opened frequently to release water.
- ▶ To reduce abrasive intrusion in the air supply hose, depressurize the abrasive blasting pot before shutting off air supply from compressor.
- ▶ Inspect abrasive blasting nozzle before placing into service. Damage to abrasive blasting nozzle liner or jacket may occur during shipping. If you receive a damaged abrasive blasting nozzle, contact your distributor immediately for replacement. Abrasive blasting nozzles placed into service may not be returned. Abrasive blasting nozzle liners are made of fragile materials and can be damaged by rough handling and striking against hard surfaces. Never use a damaged abrasive blasting nozzle.
- ▶ Abrasive blasting at optimal pressure for the abrasive used is critical to productivity. Example: For an abrasive with an optimal abrasive blasting pressure of 100 psi at the abrasive blasting nozzle, one pound per square inch of pressure loss will reduce abrasive blasting efficiency by 1.5%. A 10 psi reduction in air pressure will cause a 15% loss of efficiency. Use a Needle Pressure Gauge to identify pressure drops in your system. Consult with your abrasive supplier for the requirements of your abrasive.
- ▶ Replace abrasive blasting nozzle if liner or jacket is cracked or damaged. Replace abrasive blasting nozzle if original orifice size has worn 1/16" or more. Determine abrasive blasting nozzle wear by inserting a drill bit 1/16" larger than original size of abrasive blasting nozzle orifice. If the drill bit passes through abrasive blasting nozzle, replacement is needed.

AIR & ABRASIVE CONSUMPTION CHART

NOTICE

Failure to comply with ANY NOTICE listed below could pose a hazard to personnel or property.

- ▶ See Air & Abrasive Consumption Chart for estimated abrasive consumption rates and required air flow (cubic feet per minute). Your system must meet these minimum requirements to ensure proper function and performance.
- ▶ When it comes to air & abrasive mixtures, more is not necessarily better. Optimum abrasive blasting efficiency takes place when a lean air & abrasive mixture is used. To correctly set the abrasive metering valve, begin with the valve fully closed and slowly increase the amount of abrasive entering the airstream. As you increase the abrasive flow, watch for a “blue flame” at the exit of the abrasive blasting nozzle. Faster cutting, reduced abrasive consumption and lower clean up costs, are benefits of the “blue flame”.
- ▶ Abrasive blasting at optimal pressure for the abrasive used is critical to productivity. Example: For an abrasive with an optimal abrasive blasting pressure of 100 psi at the abrasive blasting nozzle, one pound per square inch of pressure loss will reduce abrasive blasting efficiency by 1.5%. A 10 psi reduction in air pressure will cause a 15% loss of efficiency. Use a Needle Pressure Gauge to identify pressure drops in your system. Consult with your abrasive supplier for the requirements of your abrasive.



“Blue Flame”

NOTICE

Inspect abrasive blasting nozzle before placing into service. Damage to abrasive blasting nozzle liner or jacket may occur during shipping. If you receive a damaged abrasive blasting nozzle, contact your distributor immediately for replacement. Abrasive blasting nozzles placed into service may not be returned. Abrasive blasting nozzle liners are made of fragile materials and can be damaged by rough handling and striking against hard surfaces. Never use a damaged abrasive blasting nozzle.

Air & Abrasive Consumption Chart*

Nozzle Orifice	Pressure at the Nozzle (PSI)								Air (in cfm), Abrasive & Compressor Requirements
	50	60	70	80	90	100	125	140	
No. 2 (1/8")	11	13	15	17	18	20	25	28	Air (cfm)
	67	77	88	101	112	123	152	170	Abrasive (lbs/hr)
	2.5	3	3.5	4	4.5	5	5.5	6.2	Compressor Horsepower
No. 3 (3/16")	26	30	33	38	41	45	55	62	Air (cfm)
	150	171	196	216	238	264	319	357	Abrasive (lbs/hr)
	6	7	8	9	10	10	12	13	Compressor Horsepower
No. 4 (1/4")	47	54	61	68	74	81	98	110	Air (cfm)
	268	312	354	408	448	494	608	681	Abrasive (lbs/hr)
	11	12	14	16	17	18	22	25	Compressor Horsepower
No. 5 (5/16")	77	89	101	113	126	137	168	188	Air (cfm)
	468	534	604	672	740	812	982	1100	Abrasive (lbs/hr)
	18	20	23	26	28	31	37	41	Compressor Horsepower
No. 6 (3/8")	108	126	143	161	173	196	237	265	Air (cfm)
	668	764	864	960	1052	1152	1393	1560	Abrasive (lbs/hr)
	24	28	32	36	39	44	52	58	Compressor Horsepower
No. 7 (7/16")	147	170	194	217	240	254	314	352	Air (cfm)
	896	1032	1176	1312	1448	1584	1931	2163	Abrasive (lbs/hr)
	33	38	44	49	54	57	69	77	Compressor Horsepower
No. 8 (1/2")	195	224	252	280	309	338	409	458	Air (cfm)
	1160	1336	1512	1680	1856	2024	2459	2754	Abrasive (lbs/hr)
	44	50	56	63	69	75	90	101	Compressor Horsepower
No. 10 (5/8")	308	356	404	452	504	548	663	742	Air (cfm)
	1875	2140	2422	2690	2973	3250	3932	4405	Abrasive (lbs/hr)
	68.5	79.5	90	100.5	112	122	146	165	Compressor Horsepower
No. 12 (3/4")	432	504	572	644	692	784	948	1062	Air (cfm)
	2672	3056	3456	3840	4208	4608	5570	6238	Abrasive (lbs/hr)
	96	112	127	143	154	174.5	209	236	Compressor Horsepower

*Abrasive consumption is based on abrasive with a bulk density of 100 lbs per Cubic Foot

NOTICE

Replace abrasive blasting nozzle if liner or jacket is cracked or damaged. Replace abrasive blasting nozzle if original orifice size has worn 1/16" or more. Determine abrasive blasting nozzle wear by inserting a drill bit 1/16" larger than original size of abrasive blasting nozzle orifice. If the drill bit passes through abrasive blasting nozzle, replacement is needed.

"THE BIG PICTURE"

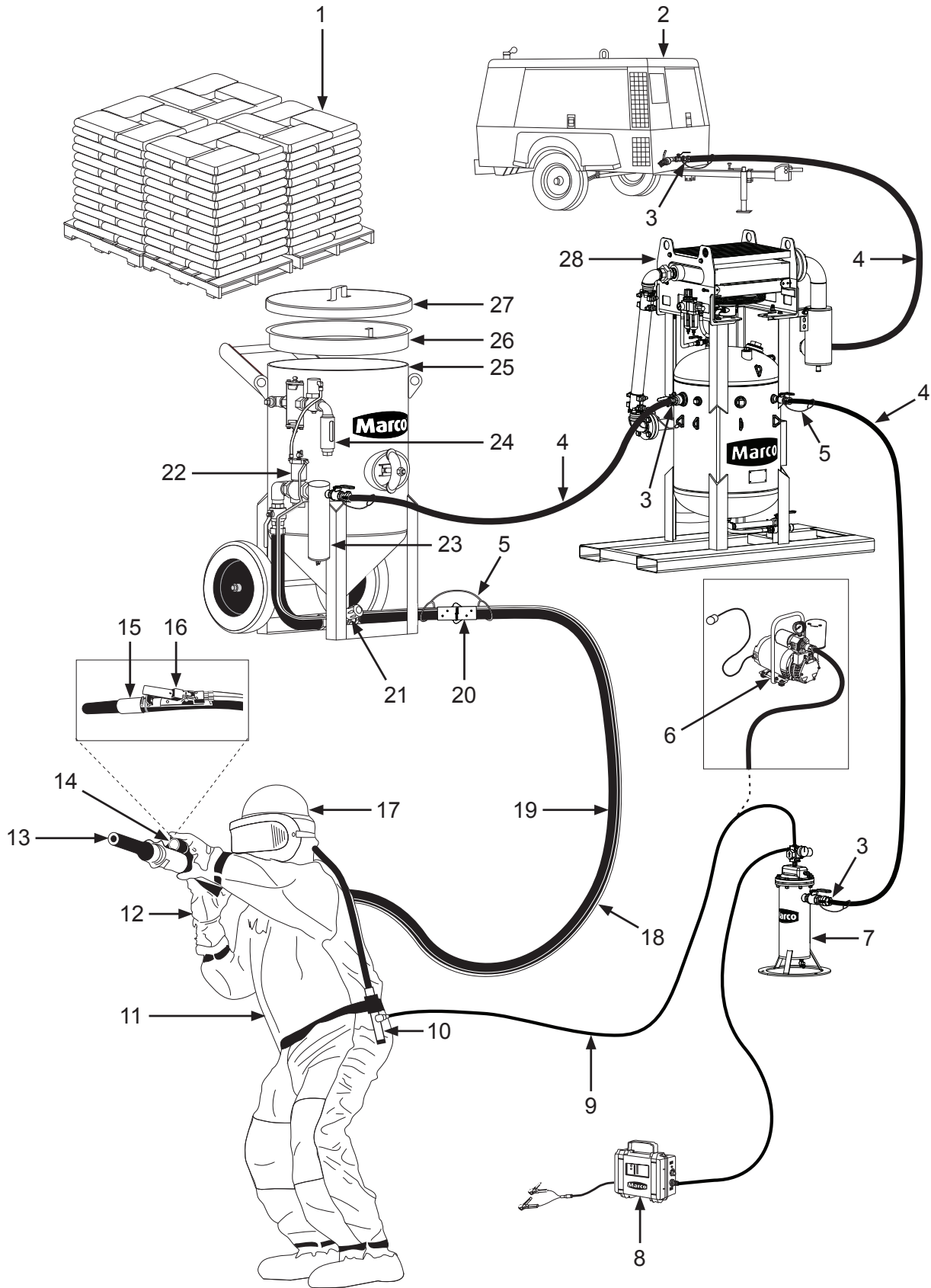

DAILY PRE-OPERATION CHECKLIST

Daily Pre-operation Checklist

- 1. Abrasive
- 2. Air Compressor
- 3. Air Hose Couplings & Gaskets
- 4. Air Hose
- 5. Safety Cable
- 6. Ambient Air Pump*
- 7. Breathing Air Filter
- 8. CO Monitor
- 9. Breathing Line
- 10. Climate Control Device
- 11. Abrasive Blasting Suit
- 12. Gloves
- 13. Abrasive Blasting Nozzle
- 14. Lighting System*
- 15. Abrasive Blasting Nozzle Holder
- 16. Remote Control Switch
- 17. Supplied-Air Respirator
- 18. Control Line
- 19. Abrasive Blasting Hose
- 20. Abrasive Blasting Hose Couplings & Gaskets
- 21. Abrasive Metering Valve
- 22. Remote Control System
- 23. Moisture Separator
- 24. Abrasive Blasting Pot Exhaust Muffler
- 25. Abrasive Blasting Pot
- 26. Abrasive Blasting Pot Screen
- 27. Abrasive Blasting Pot Lid
- 28. Aftercooler*

* *Optional or alternative device. Ask your Marco Representative for more details.*

Abrasive – Select the correct Abrasive (1) for the application. Review the SDS (*Safety Data Sheet*) to ensure the correct PPE (*Personal Protective Equipment*) and Environmental Controls have been selected and are in place.

Air Compressor – Select an Air Compressor (2) of adequate size to support all equipment requirements. Refer to “Air & Abrasive Consumption Chart” for Abrasive Blasting Nozzle (13) air consumption requirements. Before connecting Air Hose (4), sample the air being produced by the air compressor (2) to ensure it is free of petroleum contaminants.

Air Hose, and Air Hose Couplings & Gaskets – Select Air Hoses (4) of sufficient size to support all subsequent volumetric requirements and with a sufficient PSI (*pound per square inch*) rating. Inspect all Air Hoses (4), and Air Hose Couplings & Gaskets (3) for damage or wear. Repair or replace damaged or worn components.

Abrasive Blasting Hose, Abrasive Blasting Hose Couplings & Gaskets, and Abrasive Blasting Nozzle Holder – Select an Abrasive Blasting Hose (19) that has an inner diameter 3 to 4 times larger than your Abrasive Blasting Nozzle (13). Inspect Abrasive Blasting Hose (19), Abrasive Blasting Hose Couplings & Gaskets (20), and Abrasive Blasting Nozzle Holder (15) for damage or wear. Repair or replace damaged or worn components.

Safety Cables – Install a Safety Cable (5) at each Abrasive Blasting Hose (19), and Air Hose (4) connection points.

Aftercooler and Moisture Separator – Ensure Aftercooler (28) is positioned on stable ground. Keep petcock drain of Moisture Separator (23) slightly open during use. Drain both devices after each use.

Supplied-Air Respirator, Breathing Line, Breathing Air Filter, Climate Control Device, CO Monitor, Ambient Air Pump – You MUST consult the Operator’s Manual supplied with your Respiratory Equipment (6, 7, 8, 9, 10, 17) for ALL applicable instructions and warnings. Inspect all Respiratory Equipment components for damage or wear. Repair or replace damaged or worn components.

Abrasive Blasting Suit and Gloves – Select an abrasive-resistant Abrasive Blasting Suit (11) that is slightly oversized to allow ease of movement and allows air to flow around your body. Select abrasive-resistant Gloves (12) with a tight fit and a long cuff that overlaps the sleeve of the Abrasive Blasting Suit (11).

Abrasive Metering Valve and Abrasive Blasting Pot – Confirm Abrasive Blasting Pot (25) is positioned on stable ground. Inspect Abrasive Blasting Pot (25) and Abrasive Metering Valve (21) for damage or wear. Repair or replace damaged or worn components.

Abrasive Blasting Pot Screen and Abrasive Blasting Pot Lid – Always use an Abrasive Blasting Pot Screen (26) when filling Abrasive Blasting Pot (25) with Abrasive (1) to prevent debris from entering the Abrasive Blasting Pot (25). Remove Abrasive Blasting Pot Lid (27) before operating the Abrasive Blasting Pot (25). Install Abrasive Blasting Pot Lid (27) after use to protect the Abrasive Blasting Pot’s (25) interior.

Remote Control System, Remote Control Switch, Control Line, – Inspect Remote Control System (22) and Control Line (18) for damage or wear. Repair or replace damaged or worn components. Ensure Control Line (18) fittings connected to the Remote Control System (22) are tight and free of leaks. Ensure Remote Control Switch (16) is functioning properly. Consult Remote Control Switch Operator’s Manual for applicable instructions.

Abrasive Blasting Pot Exhaust Muffler – Inspect Abrasive Blasting Pot Exhaust Muffler (24) at start and end of daily use. Replace element of Abrasive Blasting Pot Exhaust Muffler (24) per Operator’s Manual instructions.

Lighting System – Ensure the Lighting System (14) is connected to a proper power supply before use.

OPERATING INSTRUCTIONS

DANGER

D-507

Do not operate this equipment without the proper pressure relief device in place. Exceeding maximum working pressure could cause vessel or components to burst. Failure to comply with the above warning will result in death or serious injury. ASME STANDARD PTC25-2014. OSHA Standard 1910.169 (B)(3)(i).

WARNING

W-594

Read, understand, and follow the Original Equipment Manufacturer operator's manuals, information, training, instructions, and warnings, for the proper and intended use of all equipment. Failure to comply with the above warning could result in death or serious injury.

WARNING

W-505

Inspect all equipment for wear or damage before and after each use. Failure to use Original Equipment Manufacturer repair parts and failure to immediately replace worn or damaged components could void warranties and cause malfunctions. Failure to comply with the above warning could result in death or serious injury.

WARNING

W-520

The use of this product for any purpose other than originally intended or altered from its original design is prohibited. Failure to comply with the above warning could result in death or serious injury.

Description

The Blastmaster® 6.0 Cu. Ft. C-Series Abrasive Blasting Pot is a pressure vessel used as part of an abrasive blasting system to deliver a mixture of abrasive and compressed air to a work surface. Marco blast pots are proudly engineered and manufactured in the USA and built in accordance with ASME guidelines. Each Marco blast pot is designed with added features to enhance work site safety. Blastmaster® Abrasive Blasting Pots are manufactured using higher quality materials that resist wear, reducing costly downtime and increasing production rates. Typical applications include blast rooms, blast yards, bridges, oil refineries, pipelines, railcar shops, storage tanks, and water towers. Common abrasives used include aluminum oxide, crushed glass, garnet, mineral abrasives, and slags.

Operational Requirements

- Proper air supply to provide a minimum of 50 psi to a maximum of 150 psi working pressure.

The following may cause safety hazards or reduced performance:

- Improper installation and/or maintenance of components.
- Failure to place Blast Pot on a secure, flat surface.
- Improper air supply pressure (maximum 150 psi).
- Incorrect lifting/transporting of Blast Pot or incorrect or worn lifting devices.

Note: Ensure no steel abrasive is being used with the Blastmaster® Regulator Abrasive Metering Valve. Use of steel grit or shot may cause internal components to bind and render the valve inoperable.

Initial Setup

- Place Blastmaster® 6.0 Cu. Ft. C-Series Abrasive Blasting Pot on a secure level surface that can withstand the weight of a full Blast Pot. Be aware of possible erosion of surface and load shifting.
- Connect air supply hose from compressor to Inlet (6) of the Blast Pot. To provide best performance, an air supply hose with an inner diameter five to six times the size of blast nozzle orifice is recommended.
- Connect blast hose to Coupling (9) installed on Abrasive Metering Valve (10).
- PNEUMATIC: Connect Pneumatic Control Line (1) to Inlet Valve (2) and Pneumatic Remote Control Switch (3).
- Ensure Petcock (4) on Inlet Valve (2) is in the OPEN position.
- Test Pneumatic Remote Control Switch (3) for proper functioning. (See pneumatic remote control switch Operator's Manual for instructions.)
- ELECTRIC: Test Electric Remote Control Switch (7) for proper functioning. (See remote control switch Operator's Manual for procedure.)
- Connect Power Cord (8) to Twist-Lock Plug (5) of Electric Control Assembly (11) and Twist-Lock Plug (12) attached to Electric Remote Control Switch (7).
- Connect Twist-Lock Plug (13) of Marco 120-Volt AC to 12-Volt AC Power Converter (14) or Battery Clamp Assembly (15) to Twist-Lock Plug (16) of Electric Control Assembly (11).

OPERATING INSTRUCTIONS

WARNING

Never weld, grind or drill ^{W-516} on the abrasive blasting pot (or any pressure vessel). Doing so will void ASME certification and manufacturer's warranty. Welding, grinding or drilling on the abrasive blasting pot (or any pressure vessel) could weaken the vessel causing it to burst. Failure to comply with the above warning could result in death or serious injury. (ASME Pressure Vessel Code, Section VIII, Division 1)

CAUTION

High decibel noise levels are generated during the abrasive blasting process which may cause loss of hearing. Ensure appropriate Personal Protective Equipment and hearing protection is in use. Failure to comply with the above caution may result in minor or moderate injury. ^{C-501}

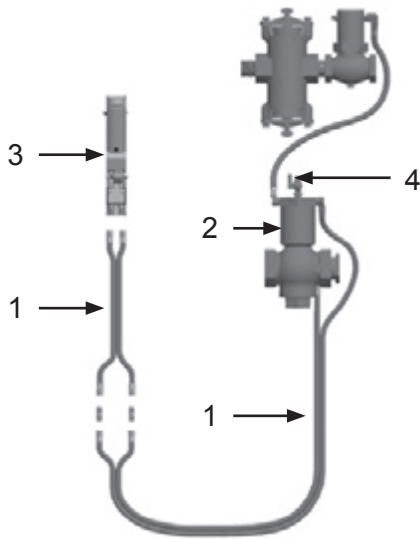
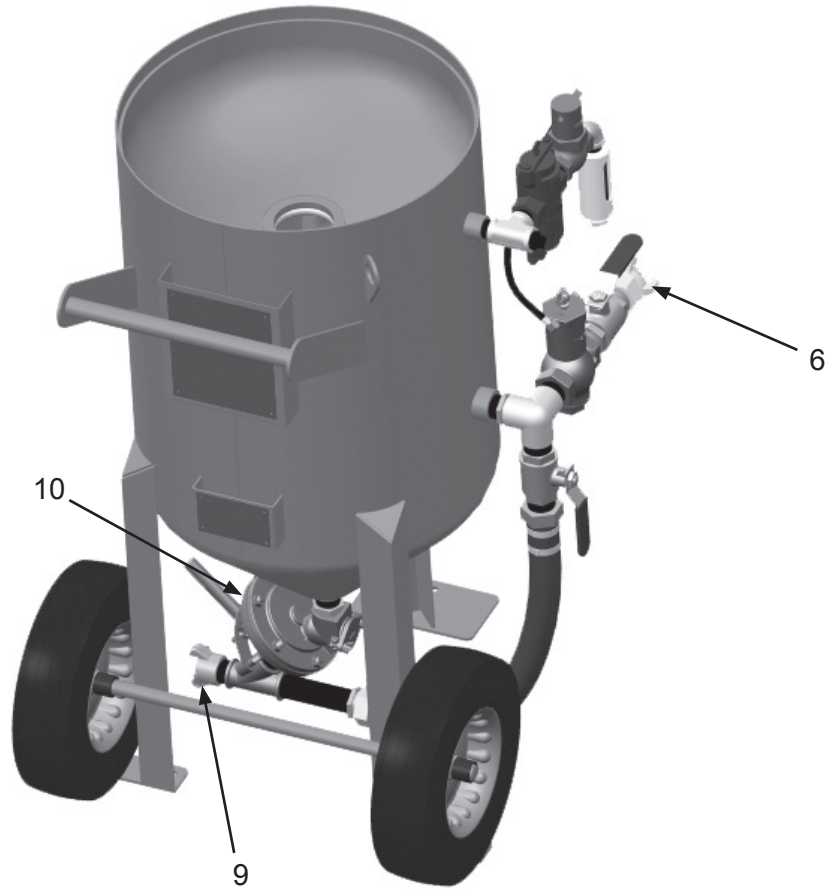

Pneumatic Remote Control

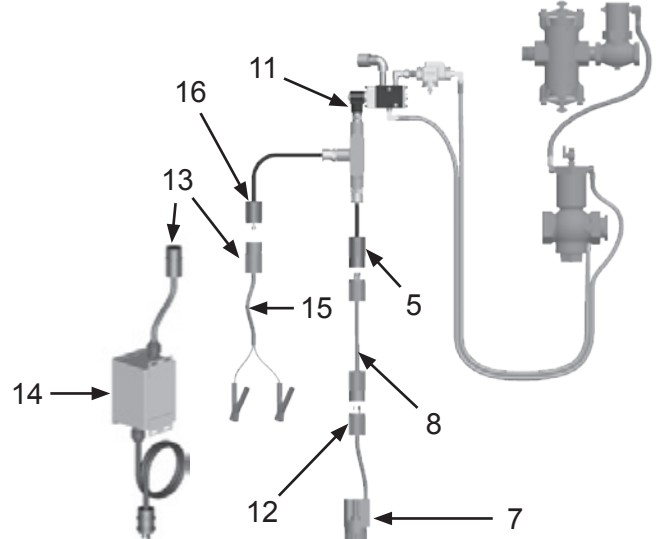

Electric Remote Control

OPERATING INSTRUCTIONS

DANGER

Do not operate this equipment without the proper pressure relief device in place. Exceeding maximum working pressure could cause vessel or components to burst. Failure to comply with the above warning will result in death or serious injury. ASME STANDARD PTC25-2014. OSHA Standard 1910.169 (B)(3)(i).

WARNING

OSHA requires blast cleaning nozzles be equipped with an operating valve, which shall be designed to be held open only by continuous hand pressure and shall close immediately upon release of hand pressure (i.e., a “deadman” control). The valve shall not be modified in any manner that would allow it to remain open without the application of continuous hand pressure by the operator. Failure to comply with the above warning could result in release of high speed abrasive and compressed air resulting in death or serious injury. OSHA 29CFR 1910.244(b)

Operating Instructions

Operating Instructions are limited to the instructions found in the Original Equipment Manufacturer’s Operator’s Manuals. Please refer to all literature included with your Blastmaster® 6.0 Cu. Ft. C-Series Abrasive Blasting Pot at time of delivery. If this literature is unavailable, please contact Marco for a replacement set before use.

Note: Do Not operate this equipment without a pressure relief device installed. OSHA and ASME Code require that all pressure vessels be operated with pressure relief devices in place., It is the responsibility of the owner of the abrasive blast pot to install a pressure relief valve that meets all regulations as set forth by local, state, and federal governments.

Before use:

- Inspect entire system for air leaks or damage. Repair or replace damaged components.
- Ensure sufficient compressed air supply volume and/or pressure.
- Inspect Pop-Up Valve Seat (2) and Pop-Up Valve (3) for damage. Replace damaged components before use.
- Inspect Muffler Assembly (4) for wear and abrasive. Repair or replace as needed.
- Inspect remote control system components.
- Inspect Pusher Line (8) for damage. Replace damaged components before use.
- Inspect Blast Pot (1) for damage. Do not use Blast Pot if damaged.

During use:

- Ensure Blast Pot is not pressurized. Fill Blast Pot (1) through hole in top of Blast Pot. Do not overfill, the capacity of the Blast Pot is 6.0 cubic feet of abrasive.
- Turn on air supply.
- Open Ball Valve (6) to pressurize Tank (1).
- Open Ball Valve (7).
- To begin abrasive blasting, activate the Remote Control Switch (11). Monitor remote control system components.
- Ensure air & abrasive mixture is correct. (See “Blue Flame” section on page 6.) To adjust the air & abrasive mixture, move Handle (12) to the fully closed position, to the right or left of the abrasive metering valve. Activate the remote control system and slowly move the handle toward the center, fully open position, of the valve. Once the appropriate setting is attained, move the Locator Pin (13) on the gauge to the fully open side of the handle. This provides a guide for the next start up.
- Evaluate the air & abrasive mixture during blasting and make adjustments to abrasive flow as necessary.

After use:

- When abrasive blasting is completed, move handle to the fully closed position to stop abrasive loss when not abrasive blasting.
- Empty abrasive from Blast Pot when blasting is concluded for the day. To remove abrasive, place Metering Valve (10) in the FULL OPEN position. Close Ball Valve (7). Remove Blast Nozzle from nozzle holder on blast hose. Ensure blast hose is placed in a container suitable for catching the abrasive. Ensure Operator is prepared for strong recoil, the blast hose will provide strong recoil as the abrasive exits the blast hose. Activate remote control system. When Blast Pot is empty, only air will exit the blast hose. Deactivate the remote control system to depressurize the Blast Pot. Place Metering Valve (10) in the CLOSED position.
- Inspect Blast Pot components for damage. Replace damaged components before use.
- Cover Blast Pot when not in use to reduce debris and water intrusion.

OPERATING INSTRUCTIONS

⚠ WARNING

Never weld, grind or drill ^{W-516} on the abrasive blasting pot (or any pressure vessel). Doing so will void ASME certification and manufacturer's warranty. Welding, grinding or drilling on the abrasive blasting pot (or any pressure vessel) could weaken the vessel causing it to burst. Failure to comply with the above warning could result in death or serious injury. (ASME Pressure Vessel Code, Section VIII, Division 1)

⚠ WARNING

The use of this product for any purpose other than originally intended or altered from its original design is prohibited. Failure to comply with the above warning could result in death or serious injury. ^{W-520}

⚠ CAUTION

High decibel noise levels are generated during the abrasive blasting process which may cause loss of hearing. Ensure appropriate Personal Protective Equipment and hearing protection is in use. Failure to comply with the above caution may result in minor or moderate injury. ^{C-501}

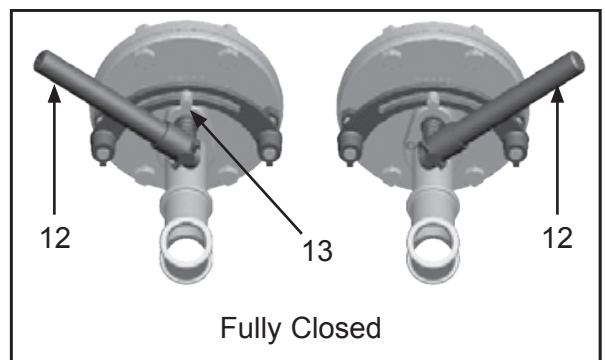
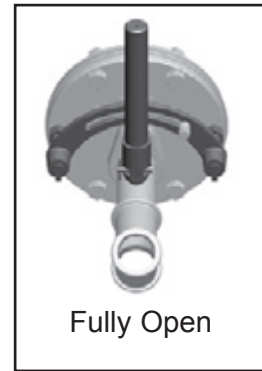
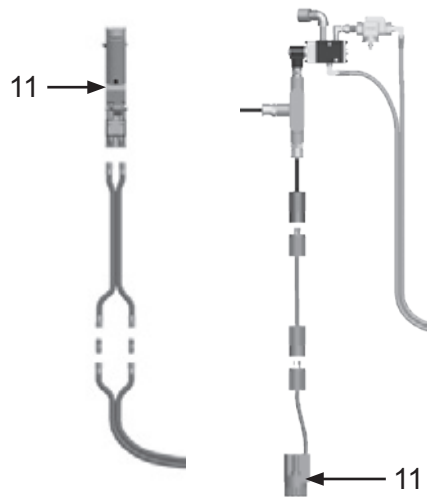
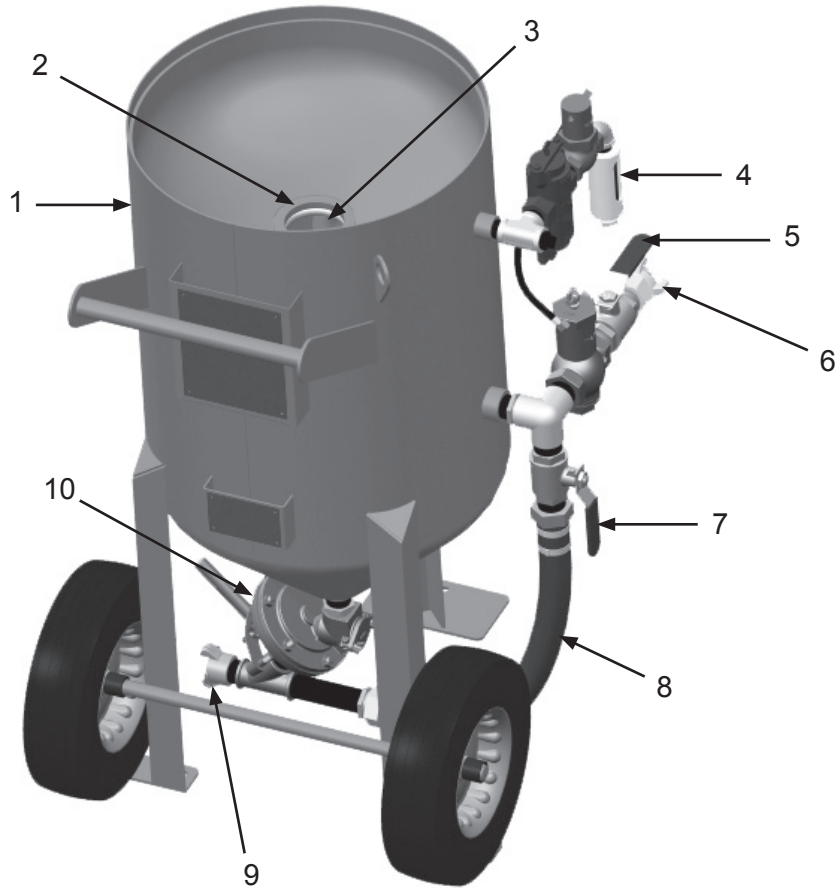

OPERATING INSTRUCTIONS

Blast Hoses and Connections

WARNING

Always depressurize the entire system, disconnect all power sources and lockout/tagout all components before any maintenance or troubleshooting is attempted. Failure to comply with the above warning could cause electrical shock and inadvertent activation of equipment resulting in death or serious injury.

W-562

CAUTION

Worn blast hose assemblies can fail while blasting. Check the full length of blast hose assembly for soft spots caused by wear. Replace blast hoses that show signs of excessive wear. Failure to comply with the above caution may result in minor or moderate injury.

C-515

CAUTION

Leaks around couplings and nozzle holders indicate worn or loose fitting parts. They could disconnect while under pressure. Inspect all couplings and nozzles daily for worn or loose fitting parts. Inspect nozzle threads for wear. Failure to comply with the above caution may result in minor or moderate injury.

C-516

Blast hoses are a high wear component of the abrasive blast system. Sharp bends in the blast hose create high wear points resulting in soft spots that can fail while blasting. Check the full length of the blast hose assembly for soft spots caused by wear. Replace any blast hoses that have soft spots or show signs of wear.

All air hose, blast hose, and threaded couplings have pin holes that align when connected. To protect against accidental hose disconnections, four Safety Pins (1) must be installed through these holes. As a secondary safety measure each hose connection should also include a Hose Whip Check (2) that will hold the hose if there is an accidental disconnection. Connect one loop to each side of connection and stretch out as shown below.

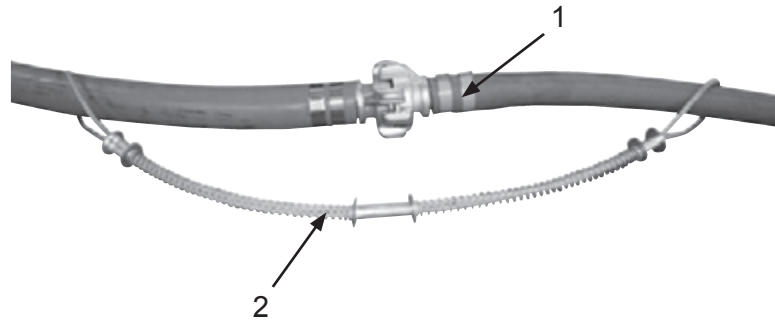

All air hose, blast hose, and threaded couplings have gaskets that seal the connection. To reduce loss of air pressure and/or premature abrasive wear replace these gaskets when visible wear or leaks are found.

Leaks around couplings and nozzle holders could indicate worn or loose fitting parts. They could disconnect while under pressure. Inspect all couplings and nozzles daily for worn or loose fitting parts. Check nozzle threads for wear.

SPECIFICATIONS

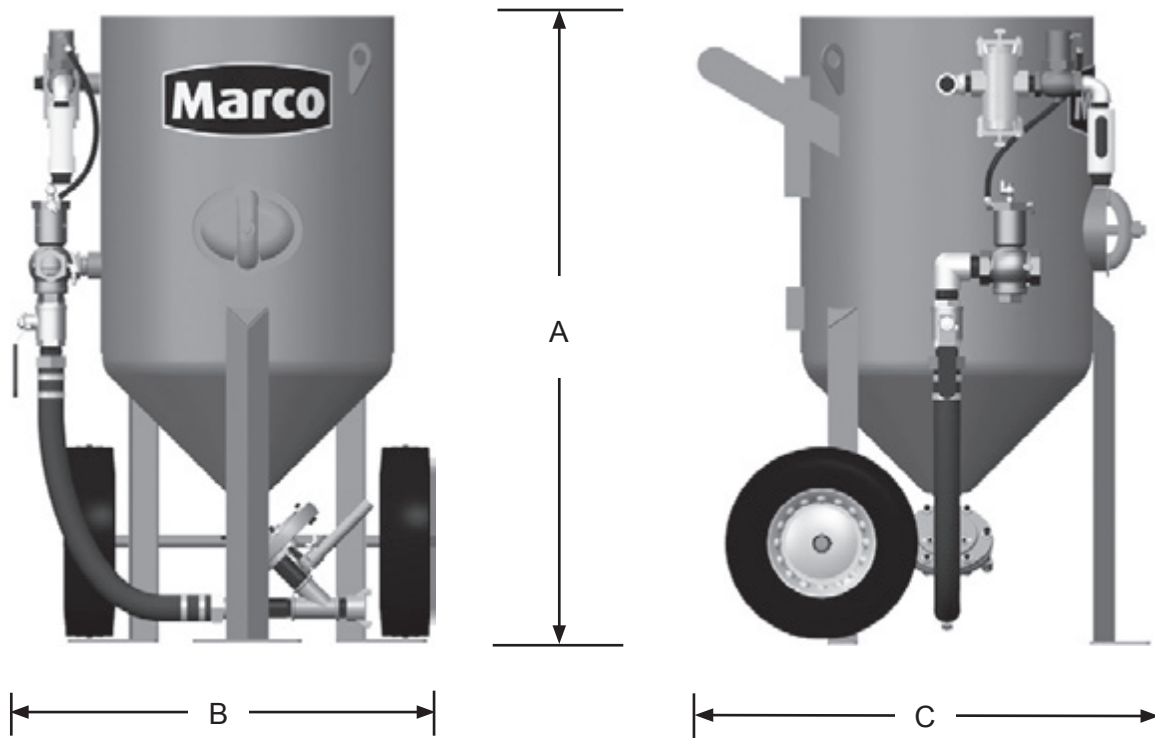

Empty Weight: 450 lbs

Overall Dimensions:

A: 52"

B: 35"

C: 37"

MAINTENANCE

Remove & Install Inspection Door Assembly

WARNING

W-562
Always depressurize the entire system, disconnect all power sources and lockout/tagout all components before any maintenance or troubleshooting is attempted. Failure to comply with the above warning could cause electrical shock and inadvertent activation of equipment resulting in death or serious injury.

CAUTION

C-504
Release of high speed abrasive and compressed air occurs during depressurization of the abrasive blasting pot. Ensure appropriate Personal Protective Equipment is in use. Failure to comply with the above caution may result in minor or moderate injury.

- 1) Depressurize the system.
- 2) Remove Nut (1) from Bolt (3).
- 3) Remove Yoke (2) from Bolt (3).
- 4) With Bolt (3) captured in slot in Door (5), grasp Bolt (3) and push on Door (5) towards the interior of Blast Pot to free the Door (5) and Gasket (4).
- 5) Remove Door (5) and Gasket (4) from Blast Pot interior.
- 6) Install parts in reverse order using the following special instructions:
 - Ensure that Yoke (2) is tight and an air-tight seal is produced.

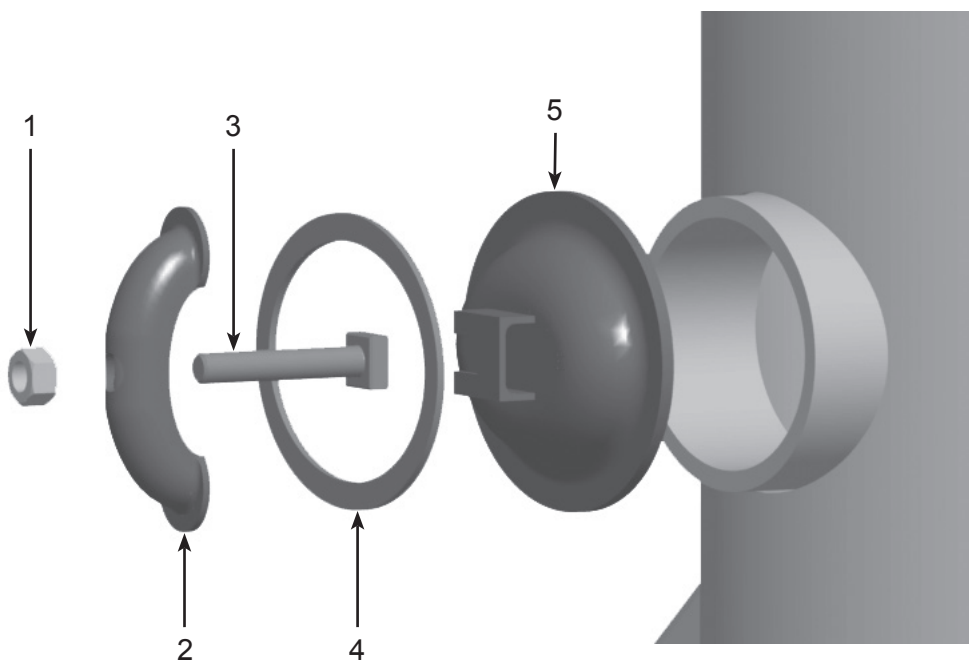

MAINTENANCE

Remove & Install Pop-up Valve

WARNING

W-562

Always depressurize the entire system, disconnect all power sources and lockout/tagout all components before any maintenance or troubleshooting is attempted. Failure to comply with the above warning could cause electrical shock and inadvertent activation of equipment resulting in death or serious injury.

WARNING

W-563

Moving parts can present an area where crushing, pinching, entanglement or amputation may occur. Do not place body parts or foreign objects in any area where there are moving parts. Failure to comply with the above warning could result in death or serious injury.

CAUTION

C-504

Release of high speed abrasive and compressed air occurs during depressurization of the abrasive blasting pot. Ensure appropriate Personal Protective Equipment is in use. Failure to comply with the above caution may result in minor or moderate injury.

NOTICE

N-519

Apply pipe thread sealant to all pipe threads to ensure an airtight seal.

- 1) Depressurize the system.
- 2) Remove Inspection Door Assembly (7). See Remove & Install Inspection Door Assembly.
- 3) Loosen Vertical Pipe Nipple (4) from Pipe Elbow (5). Remove Vertical Pipe Nipple and Pop-Up Valve (3) from the Blast Pot through inspection door opening.
- 4) Remove Pop-Up Valve (3) from Vertical Pipe Nipple (4).
- 5) From inside Blast Pot, with Pop-Up Valve (3) removed, pry Pop-Up Valve Seat (2) from recess in top of Blast Pot and remove through Fill Hole (1).
- 6) Remove Pipe Elbow (5) and Pipe Nipple (6). Inspect all components and replace if needed.
- 7) Install parts in reverse order using the following special instructions:
 - Tighten Vertical Pipe Nipple (4) 1/4 turn beyond hand tight.

Note: Apply pipe thread sealant to all pipe threads to ensure an airtight seal.

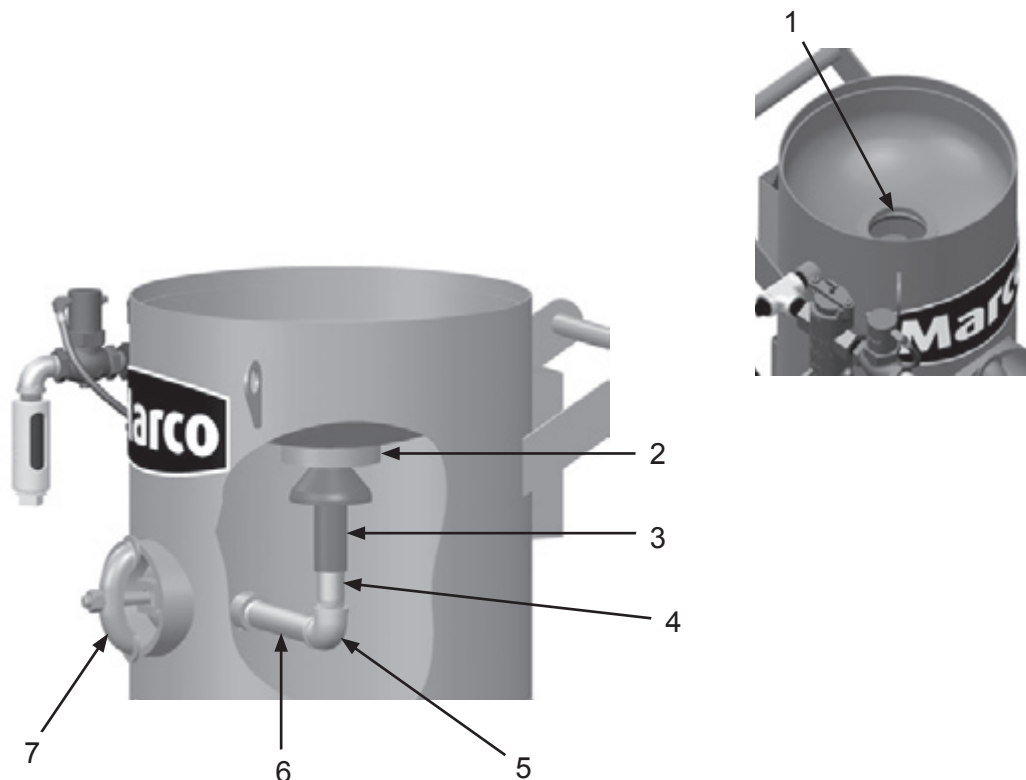

MAINTENANCE

Remove & Install Inlet Valve

WARNING

W-562
Always depressurize the entire system, disconnect all power sources and lockout/tagout all components before any maintenance or troubleshooting is attempted. Failure to comply with the above warning could cause electrical shock and inadvertent activation of equipment resulting in death or serious injury.

CAUTION

C-504
Release of high speed abrasive and compressed air occurs during depressurization of the abrasive blasting pot. Ensure appropriate Personal Protective Equipment is in use. Failure to comply with the above caution may result in minor or moderate injury.

NOTICE

N-519
Apply pipe thread sealant to all pipe threads to ensure an airtight seal.

- 1) Depressurize the system.
- 2) Disconnect Control Line (1) from Inlet Valve (5).
- 3) Remove Coupling (2), Ball Valve (3), and Nipple (4).
- 4) Disconnect Pusher Assembly (7) from Nipple (8).
- 5) Remove Nipple (8), Ball Valve (6) and Nipple (9).
- 6) Remove Nipple (11), Bushing (10), Split Elbow (12) Nipple (13) and Inlet Valve (5).
- 7) Install parts in reverse order.

Note: Apply pipe thread sealant to all pipe threads to ensure an airtight seal.

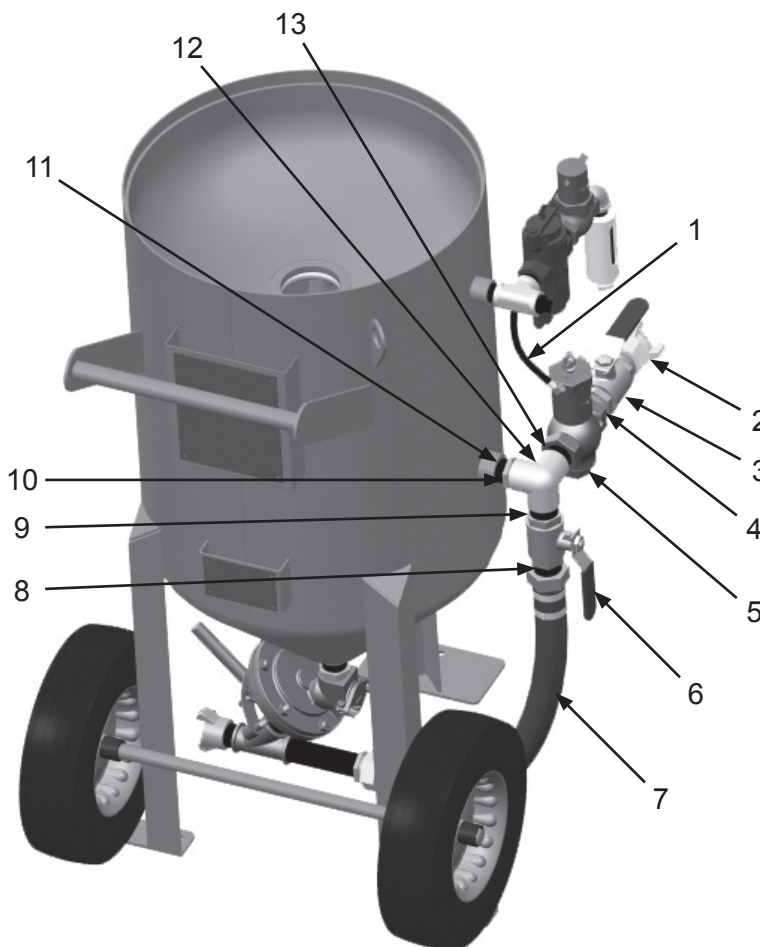

MAINTENANCE

Remove & Install Outlet Valve

WARNING

W-562
Always depressurize the entire system, disconnect all power sources and lockout/tagout all components before any maintenance or troubleshooting is attempted. Failure to comply with the above warning could cause electrical shock and inadvertent activation of equipment resulting in death or serious injury.

CAUTION

C-504
Release of high speed abrasive and compressed air occurs during depressurization of the abrasive blasting pot. Ensure appropriate Personal Protective Equipment is in use. Failure to comply with the above caution may result in minor or moderate injury.

NOTICE

N-519
Apply pipe thread sealant to all pipe threads to ensure an airtight seal.

- 1) Depressurize the system.
- 2) Disconnect Control Line (3) from Outlet Valve (1).
- 3) Remove Elbow (2).
- 4) Remove Muffler Assembly (6), Nipple (5) and Street Elbow (4).
- 5) Using Tee (7) as pivot point, rotate remaining assembly counter clockwise until Outlet Valve (1) clears top of tank.
- 6) Remove Outlet Valve (1).
- 7) Install parts in reverse order.

Note: Apply pipe thread sealant to all pipe threads to ensure an airtight seal.

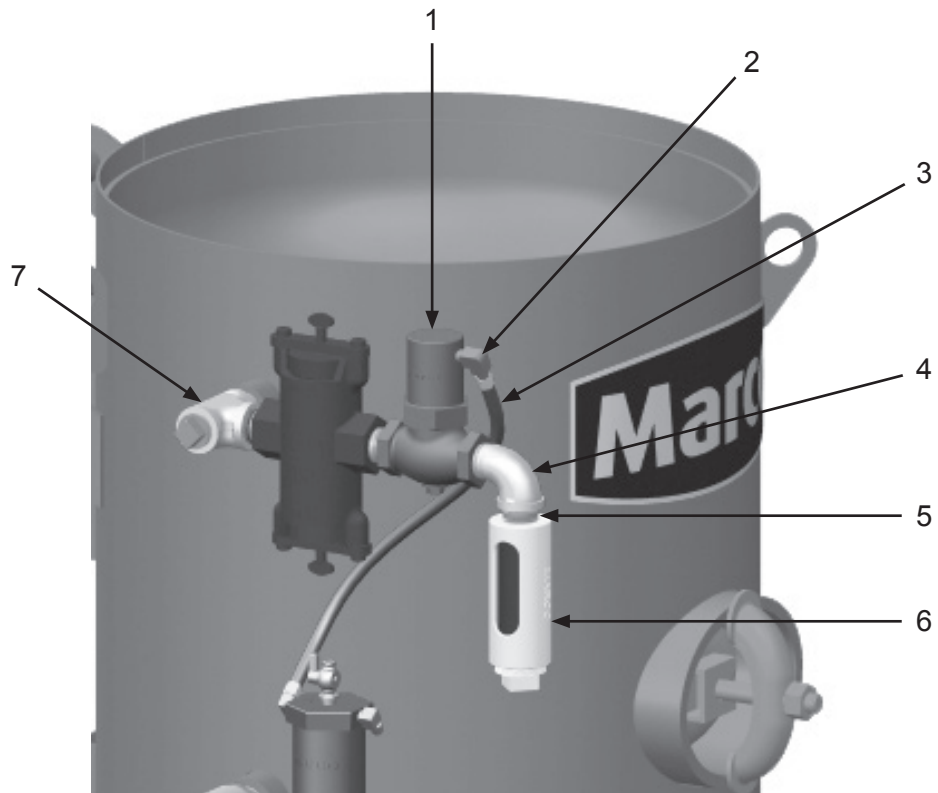

MAINTENANCE

Remove & Install Abrasive Trap

WARNING

W-562
Always depressurize the entire system, disconnect all power sources and lockout/tagout all components before any maintenance or troubleshooting is attempted. Failure to comply with the above warning could cause electrical shock and inadvertent activation of equipment resulting in death or serious injury.

CAUTION

C-504
Release of high speed abrasive and compressed air occurs during depressurization of the abrasive blasting pot. Ensure appropriate Personal Protective Equipment is in use. Failure to comply with the above caution may result in minor or moderate injury.

NOTICE

N-519
Apply pipe thread sealant to all pipe threads to ensure an airtight seal.

- 1) Depressurize the system.
- 2) Remove Outlet Valve (see Remove and Install Outlet Valve).
- 3) Remove Nipple (1), Tee (6), Plug (5), Nipple (4), Abrasive Trap (2) and Nipple (3).
- 4) Install parts in reverse order.

Note: Apply pipe thread sealant to all pipe threads to ensure an airtight seal.

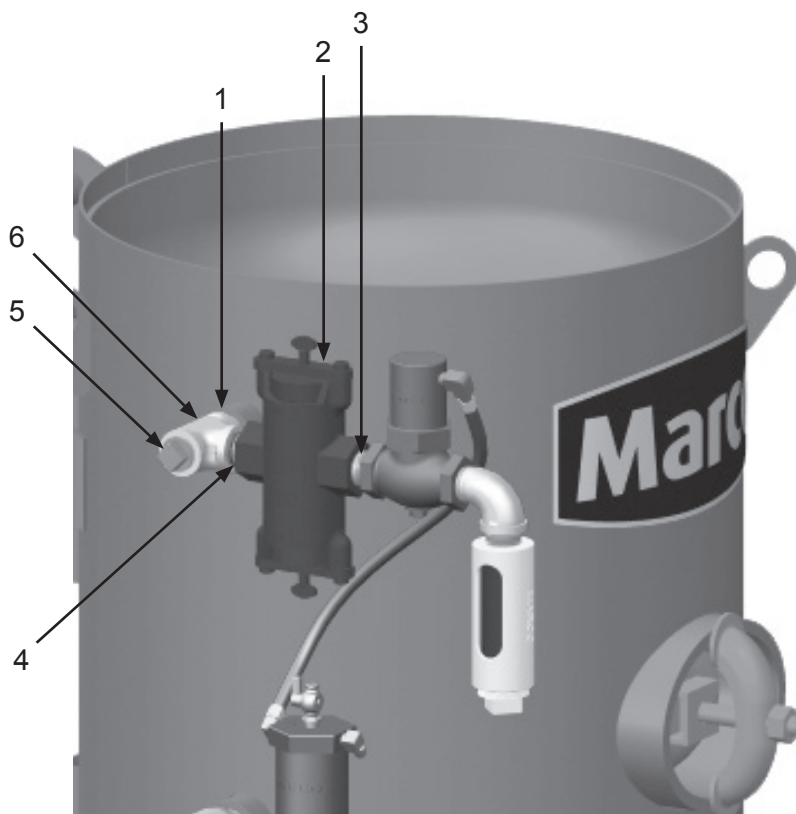

MAINTENANCE

Remove & Install Abrasive Metering Valve

WARNING

Always depressurize the entire system, disconnect all power sources and lockout/tagout all components before any maintenance or troubleshooting is attempted. Failure to comply with the above warning could cause electrical shock and inadvertent activation of equipment resulting in death or serious injury.

CAUTION

Release of high speed abrasive and compressed air occurs during depressurization of the abrasive blasting pot. Ensure appropriate Personal Protective Equipment is in use. Failure to comply with the above caution may result in minor or moderate injury.

NOTICE

Apply pipe thread sealant to all pipe threads to ensure an airtight seal.

- 1) Depressurize the system.
- 2) Disconnect Pusher Assembly (1) from Bushing (5).
- 3) Remove Pipe Nipple (6), Coupling (9), Nipple (8) and "Y" Pipe (7).
- 4) Remove Pipe Nipple (6), Abrasive Metering Valve (3) and Nipple (2).
- 5) Install parts in reverse order.

Note: Apply pipe thread sealant to all pipe threads to ensure an airtight seal.

Note: A minimum distance (A) of 13" from exit port of abrasive blast pot to the ground is required for proper installation of Blastmaster® Regulator Abrasive Metering Valve.

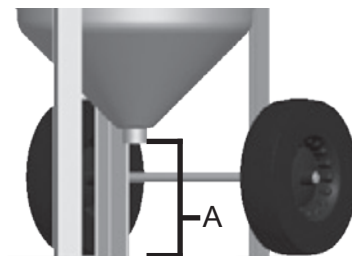
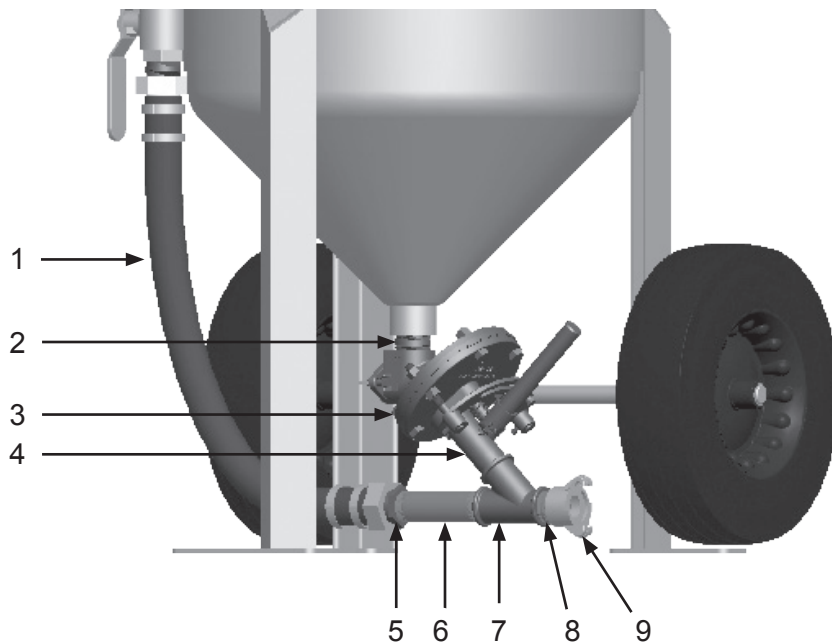

MAINTENANCE

Disassemble and Assemble 1-1/2" Inlet Valve

WARNING

W-562

Always depressurize the entire system, disconnect all power sources and lockout/tagout all components before any maintenance or troubleshooting is attempted. Failure to comply with the above warning could cause electrical shock and inadvertent activation of equipment resulting in death or serious injury.

WARNING

W-563

Moving parts can present an area where crushing, pinching, entanglement or amputation may occur. Do not place body parts or foreign objects in any area where there are moving parts. Failure to comply with the above warning could result in death or serious injury.

WARNING

W-529

Never use compressed air to separate or remove internal components during maintenance. Components could be ejected at high speeds. Failure to comply with the above warning could result in death or serious injury.

NOTICE

N-519

Apply pipe thread sealant to all pipe threads to ensure an airtight seal.

Maintenance of the 1-1/2" Inlet Valve is limited to the daily cleaning and the immediate replacement of damaged or worn parts.

Disassemble:

- 1) Remove Fittings (2,13,14) and Petcock (1). Clean or replace if damaged.
- 2) Remove Bottom Cap (10), Gasket (9), Spring (11), Spring (8), and Valve Plug Assembly (6, 7, and 12) from Body (5).
- 3) Disassemble Valve Plug Assembly by turning Valve Plug Washer Retainer (6) counter-clockwise. Remove Valve Plug Washer (12) and inspect for damage.
- 4) Remove Cylinder Cap (16). Remove O-ring (3) and inspect for damage.
- 5) Push Piston and Rod Assembly (15) through top of Body (5). Inspect O-ring (4) for damage.

Assemble:

- 1) Install O-ring (4) on Piston and Rod Assembly (15). Apply lubricant to O-ring and Piston.
- 2) Using a smooth motion, push Piston and Rod Assembly (15) into Body (5) until the assembly is a depth of 1/2" from the top of the Body (5). Do not force the assembly as damage can occur.
- 3) Place Valve Plug Washer (12) over stud on Valve Plug (7). Install Valve Plug Washer Retainer (6) on stud of Valve Plug, turning clockwise. Do not over-tighten.
- 4) Place Body (5) upside down, install Valve Plug Assembly with Valve Plug Retainer (6) toward Body. Place Spring (11) on Valve Plug (7). Insert Spring (8) inside Spring (11).
- 5) Place Gasket (9) on Body (5). Install Bottom Cap (10) over two Springs (8,11) and thread into Body.
- 6) Lubricate O-ring (3) and place on bottom of Cylinder Cap (16). Install Cylinder Cap on Body (5).
- 7) Apply pipe sealant to pipe threads of Fittings (2,13,14) and Petcock (1). Install into appropriate ports.

MAINTENANCE

Disassemble and Assemble 1-1/2" Inlet Valve (cont.)

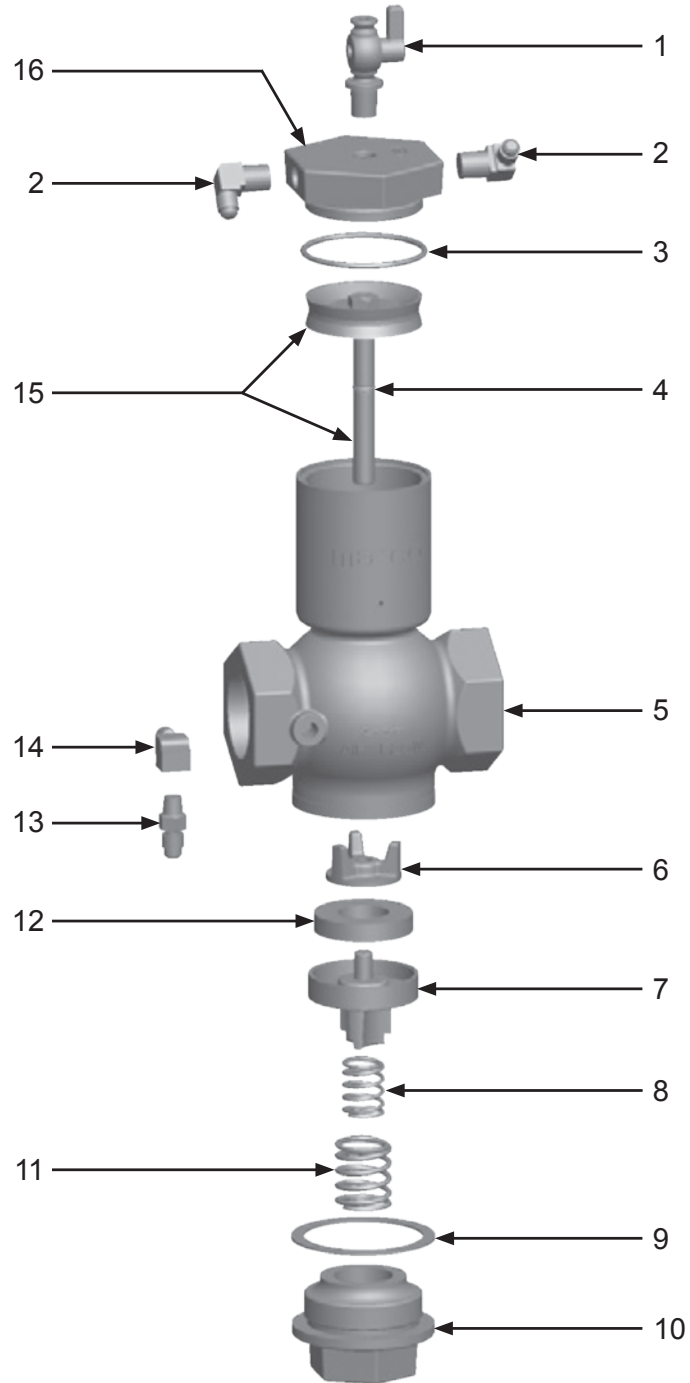

MAINTENANCE

Disassemble and Assemble 1" Outlet Valve

Maintenance of the 1" Outlet Valve is limited to the daily cleaning and the immediate replacement of damaged or worn parts.

WARNING

W-562

Always depressurize the entire system, disconnect all power sources and lockout/tagout all components before any maintenance or troubleshooting is attempted. Failure to comply with the above warning could cause electrical shock and inadvertent activation of equipment resulting in death or serious injury.

WARNING

W-563

Moving parts can present an area where crushing, pinching, entanglement or amputation may occur. Do not place body parts or foreign objects in any area where there are moving parts. Failure to comply with the above warning could result in death or serious injury.

WARNING

W-529

Never use compressed air to separate or remove internal components during maintenance. Components could be ejected at high speeds. Failure to comply with the above warning could result in death or serious injury.

NOTICE

N-519

Apply pipe thread sealant to all pipe threads to ensure an airtight seal.

Disassemble:

- 1) Remove 1/4" Elbow (1) and 1/4" NPT Pipe Plug (13) from Bonnet (2).
- 2) Remove Bonnet (2) from Valve Body (8). Spring (7) will exert minor pressure against Bonnet as it is loosened.
- 3) Remove Valve Plug Spindle Guide (4) from Bonnet (2).
- 4) Remove Valve Plug Assembly (5,6,12) and Spring (7) from Valve Body (8).
- 5) Disassemble Valve Plug Assembly by turning Valve Plug Retainer (6) counter-clockwise. Remove Valve Plug Washer (12) from Valve Plug (5).
- 6) Remove Piston and Rod Assembly (3) from Bonnet (2).
- 7) Remove Bolt (10), Nylon Washer (9), and 1" NPT Close Nipple (11) from Valve Body (8).

Assemble:

- 1) Place Nylon Washer (9) on Bolt (10) and install in Valve Body (8).
- 2) Install 1/4" Elbow (1) and 1/4" NPT Pipe Plug (13) into Bonnet (2).
- 3) Place Valve Plug Washer (12) over stud on Valve Plug (5). Install Valve Plug Washer Retainer (6) on stud of Valve Plug (5) by turning clockwise. Do not over-tighten.
- 4) Place Spring (7) over Bolt (10) in Valve Body (8).
- 5) Insert Valve Plug Washer Assembly into Valve body (8) so the center of Valve Plug Retainer (6) is centered on Spring (7). Ensure Spring is upright in Valve Body.
- 6) Apply lubricant to rubber portion of Piston and Rod Assembly (3) and insert it into Bonnet (2) until seated at the top of Bonnet.
- 7) Place Plug Spindle Guide (4) over Piston Rod and install Bonnet (2) on Valve Body (8).
- 8) Install Close Nipple (11) in outlet port of Valve Body (8).

MAINTENANCE

Disassemble and Assemble 1" Outlet Valve (cont.)

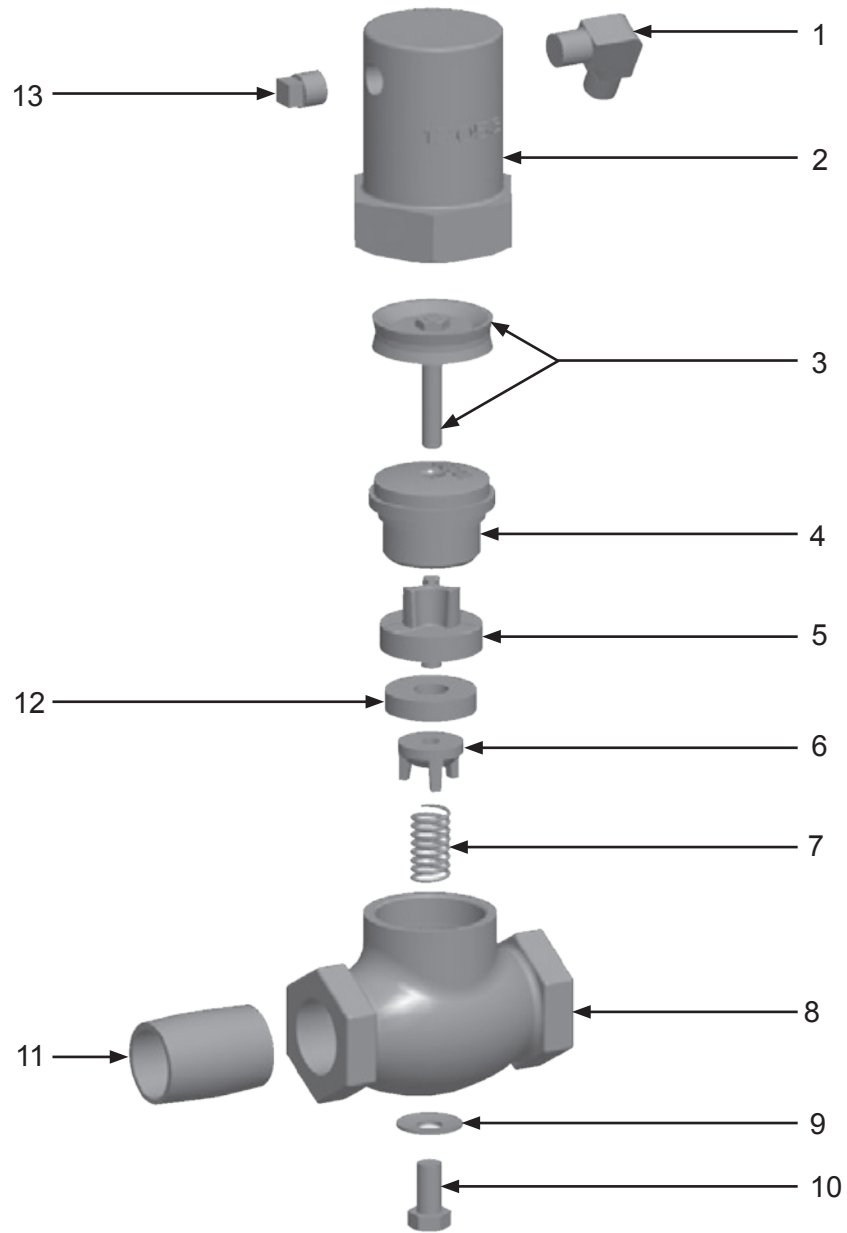

MAINTENANCE

Disassemble and Assemble Abrasive Trap

Maintenance of the Abrasive Trap is limited to the daily cleaning and the immediate replacement of damaged or worn parts.

Disassemble:

- 1) Remove Thumbscrew (1) by turning counter-clockwise.
- 2) Swing Cap Lock Bar (15) clear of Cap (3) and remove Shoulder Screws (2,16), Cap Lock Bar, and Cap.
- 3) Remove O-ring (14) from Cap (3).
- 4) Remove Screen Gasket (4) from Cap (3). Inspect parts for damage and replace as necessary.
- 5) Remove Abrasive Trap Screen (13) from upper chamber of Body (5). Clean or replace as necessary.
- 6) Remove Thumbscrew (9) by turning counter-clockwise.
- 7) Swing Cap Lock Bar (7) clear of Cap (11) and remove Shoulder Screws (8,10), Cap Lock Bar, and Cap.
- 8) Remove O-ring (6) from Cap (11).
- 9) Inspect 1" NPT Close Nipple (12). Replace as necessary.

Assemble:

- 1) Install 1" NPT Close Nipple (12) on air inlet side of Body (5).
- 2) Install Screen Gasket (4) in Cap (3). Install O-ring (14) on Cap.
- 3) Install Cap Lock Bar (15) using Shoulder Screw (2). Install Shoulder Screw (16) in opposite hole.
- 4) Place Abrasive Trap Screen (13) with large opening of screen down. Ensure it sits in recess of upper chamber of Body (5).
- 5) Install Cap (3) on Body (5), and move Cap Lock Bar (15) to rest against Shoulder Screw (16).
- 6) Install Thumbscrew (1) and tighten.
- 7) Install Cap Lock Bar (7) using Shoulder Screw (10). Install Shoulder Screw (8) in opposite hole.
- 8) Install O-ring (6) on Cap (11), and install Cap (11) on Body (5).
- 9) Move Cap Lock Bar (7) to rest against Shoulder Screw (8) and install Thumbscrew (9) and tighten.

WARNING

W-562

Always depressurize the entire system, disconnect all power sources and lockout/tagout all components before any maintenance or troubleshooting is attempted. Failure to comply with the above warning could cause electrical shock and inadvertent activation of equipment resulting in death or serious injury.

WARNING

W-563

Moving parts can present an area where crushing, pinching, entanglement or amputation may occur. Do not place body parts or foreign objects in any area where there are moving parts. Failure to comply with the above warning could result in death or serious injury.

WARNING

W-529

Never use compressed air to separate or remove internal components during maintenance. Components could be ejected at high speeds. Failure to comply with the above warning could result in death or serious injury.

NOTICE

N-521

When using fine mesh abrasives, place fine mesh steel wool in abrasive trap screen. Doing so will increase efficiency of the abrasive trap. Do not pack it in the screen as it will degrade performance of the remote control system.

MAINTENANCE

Disassemble and Assemble Abrasive Trap (cont.)

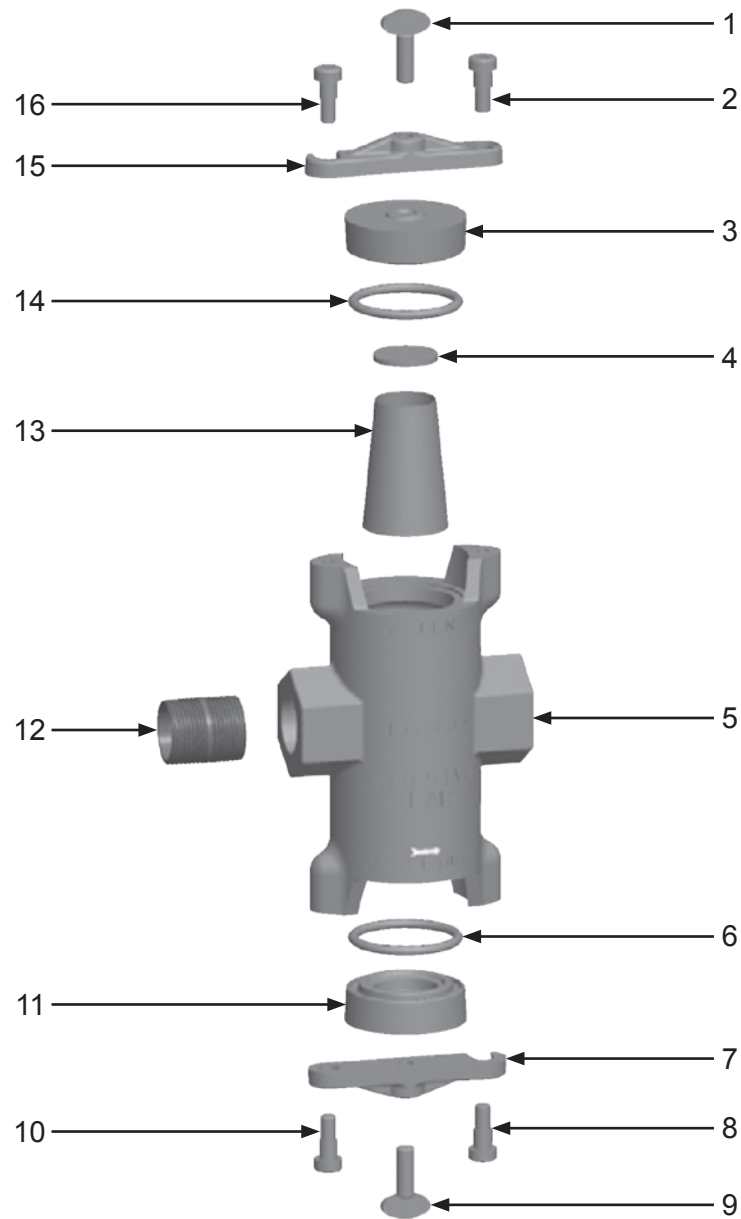

MAINTENANCE

Disassemble and Assemble Blastmaster® Regulator Abrasive Metering Valve

Maintenance of the Blastmaster® Regulator Abrasive Metering Valve is limited to the daily cleaning and the immediate replacement of damaged or worn parts.

WARNING

W-562

Always depressurize the entire system, disconnect all power sources and lockout/tagout all components before any maintenance or troubleshooting is attempted. Failure to comply with the above warning could cause electrical shock and inadvertent activation of equipment resulting in death or serious injury.

WARNING

W-563

Moving parts can present an area where crushing, pinching, entanglement or amputation may occur. Do not place body parts or foreign objects in any area where there are moving parts. Failure to comply with the above warning could result in death or serious injury.

WARNING

W-529

Never use compressed air to separate or remove internal components during maintenance. Components could be ejected at high speeds. Failure to comply with the above warning could result in death or serious injury.

NOTICE

N-519

Apply pipe thread sealant to all pipe threads to ensure an airtight seal.

Disassemble:

- 1) Remove Blastmaster® Regulator Abrasive Metering Valve from the abrasive blasting pot.
- 2) Remove 1-1/2" NPT Close Nipple (28).
- 3) Remove two Wing Nuts (26), Inspection Plate (25), O-ring (24), and two Bolts (27) from Upper Body (2).
- 4) Remove 1-1/4" NPT "Y" Pipe (15), and 1-1/4" x 5" Pipe Nipple (16).
- 5) Remove Pin Clip (14), Pin (13) and Handle (12).
- 6) Remove Spring (11), Packing Gland (10), and Packing Rope (9).
- 7) Remove six Nuts (1), four Bolts (8), Gauge Assembly, and Upper Body (2).
- 8) Remove Valve Core (4), Disc (5), two Body Gaskets (3), and Shaft Gasket (6) from Lower Body (7).
- 9) Remove Wing Nut (18), Washer (19), Spacer (20), and Bolt (21) from Gauge (23).
- 10) Remove two Set Screws (22), and Gauge (23) from two Studs (17).
- 11) Clean and inspect all parts. Replace damaged or worn parts as necessary.

Assemble:

- 1) Install Valve Core (4) in Disc (5).
- 2) Install Shaft Gasket (6) on stem of Valve Core (4).
- 3) Place a Body Gasket (3) on each side Disc (5) and align holes.
- 4) Install Lower Body (7) on stem of Valve Core (4). Align two large holes in Disc (5) and Valve Core (4) with hole in Lower Body (7).
- 5) Align bolt holes in Upper Body (2) and Lower Body (7) with bolt holes in Disc (5), and install four Bolts (8) using Nuts (1).
- 6) Install Gauge (23) on two Studs (17) using two Set Screws (22).
- 7) Place Spacer (20) on Bolt (21) and install on Gauge (23) using Washer (19), and Wing Nut (18).
- 8) Install Gauge Assembly and secure using two Nuts (1).
- 9) Install O-ring (24) on Inspection Plate (25), and install them on Upper Body (2) using two Bolts (27) and Wing Nuts (26).
- 10) Install Packing Rope (9), Packing Gland (10), Spring (11), and Handle (12). Install Pin (13), and Pin Clip (14) to retain Handle (12).
- 11) Install 1-1/4" x 5" Pipe Nipple (16) in Lower Body (7), and 1-1/4" "Y" Pipe (15) on 1-1/4" x 5" Pipe Nipple (16).
- 12) Install 1-1/2" NPT Close Nipple (28) in Upper Body (2).
- 13) Move handle left and right to ensure free movement.

MAINTENANCE

Disassemble and Assemble Blastmaster® Regulator Abrasive Metering Valve (cont.)

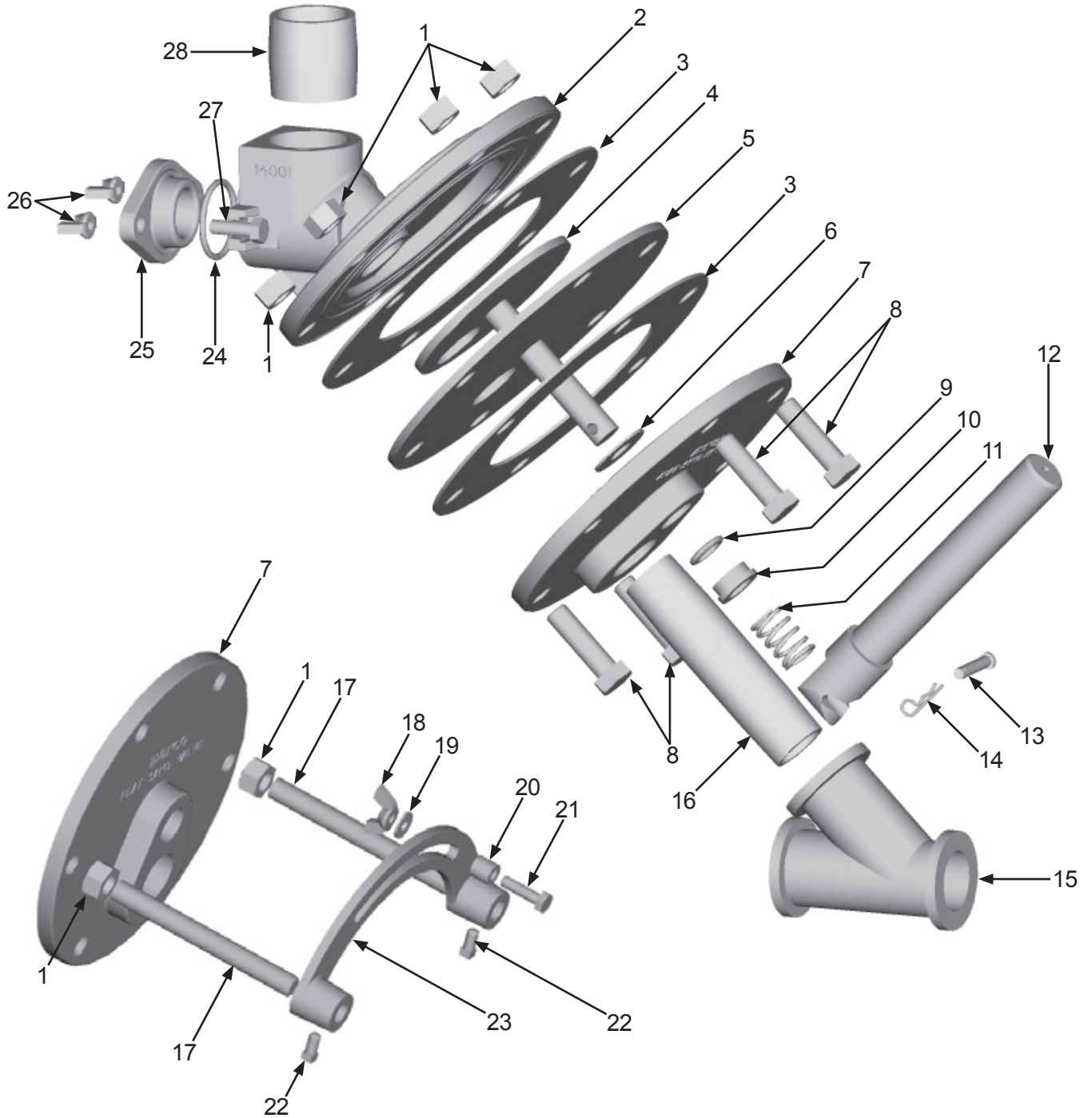

MAINTENANCE

Maintenance Schedules Quick Reference Charts

BLAST POT MAINTENANCE SCHEDULE				
Perform inspections at the intervals specified. Repair or replace damaged parts as needed.				
Item	Maintenance Required	Daily	Weekly	Monthly
Blast Pot Exterior	Visually inspect exterior of blast pot for any damage (corrosion, dents, bulges, cracks etc.). Remove from service and contact Marco.	X		
Blast Pot External Piping & Pipe Fittings	Visually inspect external pipe & pipe fittings for damage (wear, cracks, air leaks etc.). Replace as needed.	X		
Pop-up Valve and Pop-up Valve Seat	Visually inspect sealing surfaces, alignment and gap between Pop-up valve seat and Pop-up valve. Repair or replace as needed.	X		
Exhaust Muffler	Visually inspect muffler components for wear and abrasive. Empty any abrasive. Repair or replace as needed.	X		
Inspection Door Assembly	Visually inspect condition of gasket and sealing surfaces. Ensure all components are tight. Replace as needed.		X	
Identification Tags and Decals	Visually inspect for presence and condition of all identification tags and decals. Replace as needed.		X	
Blast Pot Interior	Visually inspect interior surfaces of the blast pot for wear, corrosion, pitting, cracks, or other damage. Remove from service and contact Marco. Check internal piping for wear or damage. Replace as needed.			X
Blast Pot	Hydrostatic Test	Every 5 years unless otherwise directed by local, state, or jurisdictional requirements.		

TROUBLESHOOTING

WARNING

W-562

Always depressurize the entire system, disconnect all power sources and lockout/tagout all components before any maintenance or troubleshooting is attempted. Failure to comply with the above warning could cause electrical shock and inadvertent activation of equipment resulting in death or serious injury.

WARNING

W-511

For equipment manufactured by entities other than Marco, you must consult the Original Equipment Manufacturer operator's manuals, information, training, instructions and warnings, for the proper and intended use of all equipment. Failure to comply with the above warning could result in death or serious injury.

WARNING

W-563

Moving parts can present an area where crushing, pinching, entanglement or amputation may occur. Do not place body parts or foreign objects in any area where there are moving parts. Failure to comply with the above warning could result in death or serious injury.

If the Blastmaster® 6.0 Cu. Ft. C-Series Abrasive Blasting Pot does not function properly, check the following:

SYMPTOM (Cause)

Abrasive blasting pot will not pressurize

(Damaged components, Pneumatic control line, Electric control line, Improper air supply)

ACTION

Ensure internal piping is aligned with fill hole.

Ensure pop-up valve and pop-up valve seat are seating without air leaks. Replace damaged components.

Inspect pneumatic control lines for correct routing, air leaks, blockage or pinch points. Tighten control line fittings if leaks are present. Replace damaged pneumatic control lines.

Ensure petcock located on Inlet Valve is in the closed position.

Insufficient air supply. Ensure minimum of 50 PSI is supplied to the valves.

Insufficient air supply returning to Inlet Valve from electric control assembly. Open petcock on Inlet Valve. Activate remote control switch, air should exit petcock. If air does not exit petcock, inspect pneumatic control lines for leaks or blockage. Refer to remote control switch Operator's Manual.

Ensure vent port on upper cylinder of Inlet Valve is clear of obstruction. Clean vent port if obstructed.

Inspect Inlet Valve and Outlet Valve for damage. Immediately replace damaged components.

Electric Controls:

Ensure adequate power supply is connected to electric inlet of electric control pilot valve assembly. Ensure electric control line to remote control switch is connected to electric outlet of electric control assembly.

Test electric connections for circuit continuity. Repair immediately. Inspect electric control assembly components for damage. Replace immediately if damaged.

Inspect electric control pilot valve for damage. Repair or replace as necessary.

Refer to Operator's Manual for the remote control switch and abrasive blasting pot.

TROUBLESHOOTING

WARNING

W-562

Always depressurize the entire system, disconnect all power sources and lockout/tagout all components before any maintenance or troubleshooting is attempted. Failure to comply with the above warning could cause electrical shock and inadvertent activation of equipment resulting in death or serious injury.

WARNING

W-508

Do not cut, obstruct, restrict or pinch pneumatic control lines. Doing so could prevent the proper activation and deactivation of the remote control system, resulting in the release of high speed abrasive and compressed air. Failure to comply with the above warning could result in death or serious injury.

WARNING

W-509

Frozen moisture could cause restrictions and obstructions in pneumatic control lines. Any restriction or obstruction in the pneumatic control lines could prevent the proper activation and deactivation of the remote control system, resulting in the release of high speed abrasive and compressed air. In conditions where moisture may freeze in the control lines an antifreeze injection system approved for this application can be installed. Failure to comply with the above warning could result in death or serious injury.

SYMPTOM (Cause)

No Air or Abrasive exits the Blast Nozzle

(Blockages, Wet Abrasive, Abrasive Metering Valve)

ACTION

Depressurize Blast Pot. Inspect blast nozzle and abrasive blasting hose for blockage. Remove blockage or remove components from use.

Pressurize Blast Pot using the remote control system and open and close choke valve rapidly. If problem persists refer to abrasive metering valve Operator's Manual.

Abrasive blasting pot will not depressurize or depressurizes slowly

(Damaged components, Pneumatic control lines, Electric control lines, Obstruction in system exhaust)

Inspect pneumatic control lines for correct routing, air leaks, blockage or pinch points. Tighten control line fittings if leaks are present. Replace damaged pneumatic twinline or single line hoses.

Ensure control air fitting on lower portion of Inlet Valve is not full port. Replace immediately with 1/16" orifice restrictor fitting.

Clean Abrasive Trap and Abrasive Trap Screen.

Ensure connections on pneumatic control line from Inlet Valve to Outlet Valve are secure and do not leak. Replace immediately if damaged.

Inspect Inlet Valve and Outlet Valve. Replace damaged components immediately.

Electric Controls:

Inspect electric control assembly for damage or blockage. Replace immediately if damaged.

Refer to Operator's Manual for the abrasive blasting remote control switch and abrasive blasting pot.

TROUBLESHOOTING

WARNING

W-562

Always depressurize the entire system, disconnect all power sources and lockout/tagout all components before any maintenance or troubleshooting is attempted. Failure to comply with the above warning could cause electrical shock and inadvertent activation of equipment resulting in death or serious injury.

WARNING

W-508

Do not cut, obstruct, restrict or pinch pneumatic control lines. Doing so could prevent the proper activation and deactivation of the remote control system, resulting in the release of high speed abrasive and compressed air. Failure to comply with the above warning could result in death or serious injury.

WARNING

W-509

Frozen moisture could cause restrictions and obstructions in pneumatic control lines. Any restriction or obstruction in the pneumatic control lines could prevent the proper activation and deactivation of the remote control system, resulting in the release of high speed abrasive and compressed air. In conditions where moisture may freeze in the control lines an antifreeze injection system approved for this application can be installed. Failure to comply with the above warning could result in death or serious injury.

SYMPTOM (Cause)

Intermittent abrasive flow

(Wet Abrasive, Abrasive Metering Valve, Blast Nozzle)

ACTION

Damp or wet abrasive. Remove abrasive from Blast Pot by cleaning out the vessel. Ensure dry abrasive is used.

Install a moisture separator at the inlet of the Blast Pot. Increase the inner diameter of air supply hose.

Blast nozzle is worn or too large for compressor size. Replace blast nozzle.

Inconsistent activation/deactivation

(Damaged components, Improper electrical connections)

Lubricate the Inlet Valve and Outlet Valve by introducing lightweight oil through the petcock on the Inlet Valve. This should be performed weekly.

Inspect Inlet Valve, Outlet Valve, Abrasive Trap, and electric control assembly, and all pneumatic control lines, and electric control lines for damage. Replace damaged components immediately.

Ensure control air fitting on lower portion of Inlet Valve is not full port. Replace immediately with 1/16" orifice restrictor fitting.

Electric Controls:

Inspect Dust Eliminator for damage or blockage. Replace immediately if damaged.

Test electric connections for circuit continuity. Repair connections immediately.

ADDITIONAL TECHNICAL DATA

The associations listed below offer information, materials and videos pertaining to abrasive blasting and safe operating practices.

- **American Society for Testing and Materials (ASTM)**
100 Barr Harbor Drive
West Conshohocken, PA 19428-2959
Phone: (610) 832-9585
FAX: (610) 832-9555
www.astm.org
- **Occupational Safety & Health Administration (OSHA)**
United States
Department of Labor
200 Constitution Avenue
Washington, DC 20210
Phone: (800) 321-OSHA
(800) 321-6742
www.osha.gov
- **The National Board of Boiler & Pressure Vessel Inspectors**
1055 Crupper Avenue
Columbus, Ohio 4322
Phone: (614) 888-8320
FAX: (614) 888-0750
www.nationalboard.org
- **National Association of Corrosion Engineers (NACE)**
1440 South Creek Drive
Houston, TX 77084-4906
Phone: (281) 228-6200
FAX: (281) 228-6300
www.nace.org
- **The Society for Protective Coatings (SSPC)**
40-24th Street, 6th Floor
Pittsburgh, PA 15222-4656
Phone: (412) 281-2331
FAX: (412) 281-9992
www.sspc.org
- **American National Standards Institute (ANSI)**
1899 L Street, NW, 11th Floor
Washington, DC 20036
Phone: (202) 293-8020
FAX: (202) 293-9287
www.ansi.org

LIMITED WARRANTY

Seller warrants to the original purchaser that the Product covered by this Limited Warranty will remain free from defects in workmanship or material under normal commercial use and service for a period of one year from the date of shipment to the original Purchaser. This Warranty shall not apply to defects arising, in whole or in part, from any accident, negligence, alteration, misuse or abuse of the Product, operation of the Product which is not in accordance with applicable instructions or manuals or under conditions more severe than, or otherwise exceeding, those set forth in the written specifications for the Product, nor shall this Warranty extend to repairs or alterations of the Product and/or any maintenance part by persons other than Seller or Seller's authorized representatives. This warranty does not apply to accessory items. Further, this Warranty does not apply to damage or wear to the surface finish or appearance of the Product or normal wear and tear to the Product. This Warranty is limited to a purchaser who purchases the Product either directly from the Seller or from one of Seller's "Authorized Distributors". An Authorized Distributor is a Seller approved distributor that purchases the Product directly from the Seller for the sole purpose of re-selling the Product at retail, without any use or modifications whatsoever, to an end-purchaser. This warranty is specifically non-assignable and non-transferable.

DISCLAIMER OF WARRANTY

The foregoing Limited Warranty is exclusive and is in lieu of all other warranties, whether oral or written and whether express, implied, or statutory. SELLER HEREBY DISCLAIMS ALL OTHER WARRANTIES, INCLUDING BUT NOT LIMITED TO THE WARRANTIES OF MERCHANTABILITY AND/OR FITNESS FOR A PARTICULAR PURPOSE AND ALL SUCH OTHER WARRANTIES ARE HEREBY EXCLUDED AND ARE INAPPLICABLE TO THE PRODUCT. Seller makes no warranties or representations of any kind concerning respirators, or equipment made by other manufacturers. Seller's agents and representatives are not authorized to offer any further warranties.

EXCLUSIVE REMEDY FOR WARRANTY CLAIMS

THE SOLE AND EXCLUSIVE REMEDY UNDER THE FOREGOING LIMITED WARRANTY, AND TO THE EXTENT PERMITTED BY LAW, ANY WARRANTY OR CONDITION IMPLIED BY LAW, COVERING THIS PRODUCT SHALL BE, AT THE SELLER'S OPTION, THE REPAIR OR REPLACEMENT, FREE OF CHARGE, F.O.B. POINT OF MANUFACTURE, OF ANY DEFECTIVE PART OR PARTS OF THE PRODUCT THAT WERE MANUFACTURED BY SELLER, AND WHICH ARE RETURNED TO SELLER AT SELLER'S PRINCIPAL PLACE OF BUSINESS, POSTAGE PREPAID BY THE PURCHASER. THIS SOLE AND EXCLUSIVE REMEDY IS CONDITIONED UPON PURCHASER'S PROMPT WRITTEN NOTICE TO SELLER AT SELLER'S PLACE OF BUSINESS THAT A DEFECT HAS BEEN DISCOVERED, TOGETHER WITH A REASONABLY DETAILED DESCRIPTION OF THE DEFECT IN THE PRODUCT, PROOF OF PURCHASE OF THE PRODUCT, AND THE MODEL AND IDENTIFICATION NUMBER OF THE PRODUCT WITHIN THIRTY (30) DAYS AFTER DISCOVERY OF THE DEFECT, OTHERWISE SUCH CLAIMS SHALL BE DEEMED WAIVED. NO ALLOWANCE WILL BE GRANTED FOR ANY REPAIRS OR ALTERATIONS MADE BY PURCHASER OR OTHERS WITHOUT SELLER'S PRIOR WRITTEN CONSENT. IF SUCH NOTICE IS TIMELY GIVEN, SELLER WILL HAVE THE OPTION TO EITHER MODIFY THE PRODUCT OR COMPONENT PART THEREOF TO CORRECT THE DEFECT, REPLACE THE PRODUCT OR PART WITH COMPLYING PRODUCTS OR PARTS, OR REFUND THE AMOUNT PAID FOR THE DEFECTIVE PRODUCT, ANY ONE OF WHICH WILL CONSTITUTE THE SOLE LIABILITY OF SELLER AND FULL SETTLEMENT OF ALL CLAIMS. IN NO EVENT SHALL SELLER BE LIABLE FOR ANY OBLIGATION GREATER THAN THE ORIGINAL PURCHASE PRICE OF THE PRODUCT UNDER THIS WARRANTY. PURCHASER SHALL AFFORD SELLER PROMPT AND REASONABLE OPPORTUNITY TO INSPECT THE PRODUCT FOR WHICH A CLAIM IS MADE. THE SOLE PURPOSE OF THE FOREGOING STIPULATED EXCLUSIVE REMEDY SHALL BE TO REPAIR OR REPLACE DEFECTIVE PRODUCTS OR COMPONENTS THEREOF, OR TO REFUND PURCHASER THE PURCHASE PRICE THEREOF. THIS STIPULATED EXCLUSIVE REMEDY SHALL NOT BE DEEMED TO HAVE FAILED OF ITS ESSENTIAL PURPOSE SO LONG AS SELLER IS WILLING AND ABLE TO REPAIR OR REPLACE THE DEFECTIVE PARTS OR REFUND THE PURCHASE PRICE IN ACCORDANCE WITH THE TERMS HEREOF. PRODUCTS THAT HAVE BEEN REPAIRED OR REPLACED UNDER THIS WARRANTY DO NOT RECEIVE A NEW WARRANTY AND ARE ONLY COVERED BY THE REMAINING PORTION OF THE ORIGINAL WARRANTY.

LIMITATION OF REMEDIES

The foregoing stipulated exclusive remedy is in lieu of all other remedies for breach of contract, warranty, and/or tort or otherwise. Seller shall not be liable, either directly or indirectly, for any consequential, incidental or special losses or damages of Purchaser, including but not limited to the Purchaser's expenses for downtime or for making up downtime, damages for which the Purchaser may be liable to other persons and/or entities, damages to property, and injury to or death of any persons and/or any claims for incidental or consequential damages, including but not limited to loss of profits, regardless of whether Seller has been informed of the possibility of such damages. Seller neither assumes, nor authorizes any person to assume for it, any other liability in connection with the sale or use of any Products covered by the foregoing Warranty and Disclaimers, and there are no oral agreements relating to remedies which are collateral to or which affect this limitation.

GLOBAL HEADQUARTERS

- 3425 East Locust Street
Davenport, IA 52803

ph: 800.BLAST.IT (800.252.7848)
ph: 563.324.2519
fax: 563.324.6258

REGIONAL BRANCH OFFICES

- **Iowa**
Davenport
- **Louisiana**
Gonzales
Lafayette
- **Ohio**
Youngstown
- **Texas**
Beaumont
Corpus Christi
Deer Park



ABRASIVES
BLASTING
COATING
DUST COLLECTORS
ENGINEERED SYSTEMS
RENTAL
SAFETY
SERVICE & REPAIR
VACUUMS

40+ NATIONWIDE SHIPPING LOCATIONS



★ Marco Regional Branch Offices
and Shipping Locations

● Direct Shipping Locations

CONTACT MARCO

800.BLAST.IT
(800.252.7848)
563.324.2519
FAX: 563.324.6258

WWW.MARCO.US
SALES@MARCO.US