

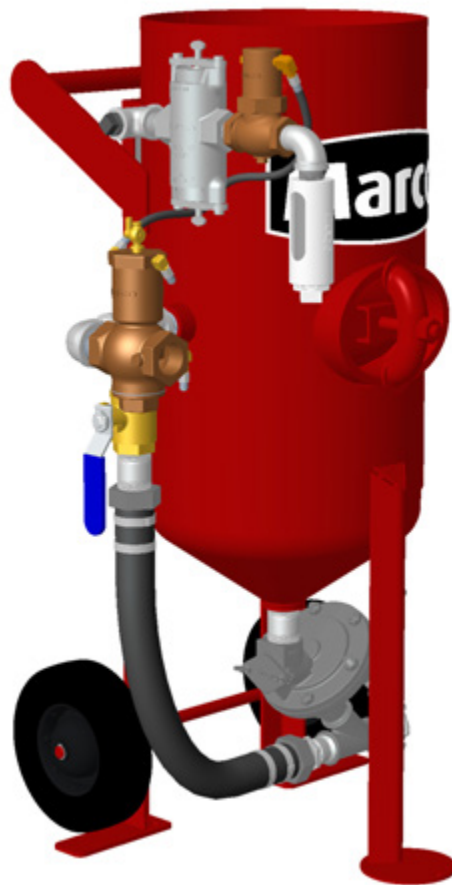

# BLASTMASTER® 3.0 CU. FT. C-SERIES ABRASIVE BLASTING POT



**BUILT MARCO**  
**TOUGH**  
MARCO MANUFACTURED

## PART NUMBERS AND SCHEMATICS GUIDE

## Company Profile

Since 1944, Marco has developed a strong tradition of providing innovative and reliable products and services to the surface preparation and protective coatings industries. We are the world's premier provider of Abrasives, Blasting, Coating, Dust Collectors, Engineered Systems, Rental, Safety, Service, Repair, & Modernization, and Vacuums.

Through innovative designs and a total commitment to quality, Marco manufactures products that increase production rates, create a safer workplace, and reduce maintenance costs. Marco's industry experience, manufacturing capabilities, legendary customer service, product availability, logistics services, and technology leadership is your assurance that we deliver high quality products and services, providing the best value to you, our customer.

## The Marco Difference

- **Industry Experience** – With Marco on your team, you have access to expertise which can only come from decades of industry leadership. We have organized our engineering department, production specialists, customer operations, and safety support into a "Center of Competence." As a Marco customer, you have access to hundreds of years of cumulative experience related to your operations.
- **Manufacturing Excellence** – Marco is a manufacturer of equipment for the Surface Preparation and Protective Coatings industries. Marco's engineers benchmark the industry to ensure that we design and manufacture superior products that set the "Gold Standard" for performance, safety, and quality.
- **Legendary Customer Service** – Marco's legendary customer service team is staffed by friendly, highly-trained individuals who are focused on providing the highest level of product support, order accuracy, and customer satisfaction.
- **Product Availability** – We stock over 10,000 SKU's and have more than 45 shipping locations to serve North American and International markets for all major brands of blasting and coating equipment. As the largest provider of surface preparation and protective coatings equipment in the world, our inventory levels and product availability are unmatched.
- **Logistics Services** – Marco's in-house logistics team is dedicated to moving your shipment anywhere in the world. We move more than 14,000 truckloads every year, allowing you to save on freight costs by leveraging our buying power. Lower your process costs with a single invoice, which includes product and freight.
- **Technology Leadership** – Our website provides: Operator's Manuals, Part Numbers and Schematics Guides, SDS information, and Features & Specifications Guides, providing access to information 24/7. Our Extranet application allows you to receive quotes and place orders online. Our Intranet maintains a complete record of your purchase history to assist with ongoing support of your existing equipment and future purchasing decisions.

## Vision Statement

Marco is the world's premier provider of Abrasives, Blasting, Coating, Dust Collectors, Engineered Systems, Rental, Safety, Service, Repair, & Modernization, and Vacuums.

## Mission Statement

Marco provides strong leadership and innovation to the surface preparation and protective coatings industries. We dedicate our efforts to the continuous improvement of our products, services, processes, people, and most importantly, the quality of our customer's experience.

## Quality Statement

Marco is committed to providing superior quality in the design, manufacturing, distribution, rental, service, and repair of our products. Continuous improvement of our processes and supply chain Integration comprise the core of our business strategy for delivering exceptional quality and value in all Marco products and services.

## Management Philosophy

We are a company dedicated to the success of every customer and associate. We discuss, debate, challenge, measure, and test our ideas. We will be boundless and limitless in our passion to improve. Through sound leadership and dedicated associates, we will ensure a long term, profitable future for Marco, our associates, customers, and suppliers.

# TABLE OF CONTENTS

## CONTENTS

Part Numbers .....	4
Part Numbers and Schematics .....	5
Inspection Door Assembly .....	5
Pop-up Valve Assembly .....	5
Blastmaster® 3.0 Cu. Ft. C-Series Abrasive Blasting Pot – Pneumatic .....	6
Blastmaster® 3.0 Cu. Ft. C-Series Abrasive Blasting Pot – Electric .....	8
Pusher Line Assembly .....	10
Exhaust Muffler Assembly .....	11
Blastmaster® 125P Remote Control System .....	12
1-1/2" Inlet Valve .....	14
1" Outlet Valve .....	15
Abrasive Trap .....	16
120-Volt AC to 12-Volt AC Power Converter .....	17
12-Volt DC Blastmaster® 125E Remote Control System .....	18
12-Volt DC 190 Electric Control Assembly .....	20
12-Volt DC 190 Electric Solenoid .....	21
120-Volt AC Blastmaster® 125E Remote Control System .....	22
12-Volt AC 190 Electric Control Assembly .....	24
12-Volt AC 190 Electric Solenoid .....	25
Blastmaster® Regulator Abrasive Metering Valve ...	26
Optional Accessories .....	28
1-1/4" Junior Extracor Abrasive Blasting Pot Moisture Separator .....	28
Lid and Screen .....	29

## PART NUMBERS

### BLASTMASTER® 3.0 CU. FT. C-SERIES ABRASIVE BLASTING POT

Part Numbers	Power Source	Blastmaster® Remote Control System	Blastmaster® Remote Control Switch	Blastmaster® Regulator Abrasive Metering Valve	1-1/4" Junior Extractor Abrasive Blasting Pot Moisture Separator
<b>1003008</b>	Pneumatic	125P	150P	X	
<b>1003008PKA</b>	Pneumatic	125P	150P	X	X
<b>1003002</b>	12-Volt DC	125E	151E	X	
<b>1003002PKA</b>	12-Volt DC	125E	151E	X	X
<b>1003004</b>	120-Volt AC	125E	151E	X	
<b>1003004PKA</b>	120-Volt AC	125E	151E	X	X

## PART NUMBERS AND SCHEMATICS

**Figure 1: Inspection Door Assembly**

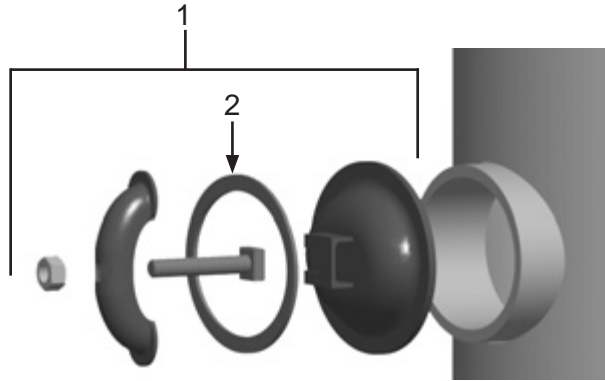

Item #	Part #	Description
--------	--------	-------------

**Fig. 1**

1	1006200	6" x 8" Inspection Door Assembly
2	1006201	Gasket

**Figure 2: Pop-up Valve Assembly**

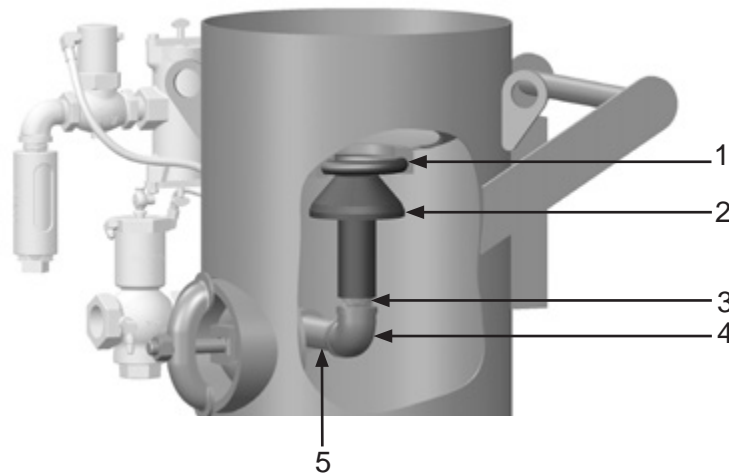

Item #	Part #	Description
--------	--------	-------------

**Fig. 2**

1	1006050	Pop-Up Valve Seat
2	1006020	Pop-Up Valve – External Sleeve
3	1006206	1-1/4" NPT x 5" Toe Nipple
4	1006204	1-1/4" 90° Elbow
5	1011202	1-1/4" NPT x 6" Pipe Nipple

## PART NUMBERS AND SCHEMATICS GUIDE

### Blastmaster® 3.0 Cu. Ft. C-Series Abrasive Blasting Pot – Pneumatic

Item #	Part #	Description
<b>Fig. 3</b>		
1	1012050	1" Outlet Valve (See Literature 106M014)
2	10CL18	18" Control Line
3	1011801	1" Galvanized Street Elbow
4	1011100	Abrasive Blasting Pot Muffler (See Fig. 6)
5	1012200	1-1/2" Inlet Valve (See Literature 106M014)
6	1011203	1-1/2" x 3" Galvanized Nipple (Two Required)
7	1014000	Blastmaster® Regulator Abrasive Metering Valve (See Literature 106M021)
8	10SB1	1-1/4" Brass Tank Coupling
9	1011201	1-1/4" Galvanized Close Nipple (Two Required)
10	1011206	1-1/4" x 2-1/2" Galvanized Nipple
11	1011501	1-1/2" (M) x 1-1/4" (F) Galvanized Hex Bushing
12	1006211	3/4" Wheel Clip (Two Required) for units built after March 2021
	1006205	1" Wheel Clip (Four Required) for units built before March 2021
13	10106067	10" Wheel (Two Required) for units built after March 2021
	1006064	16" Wheel (Two Required) for units built before March 2021
14	1006312	1-1/2" I.D. Pusher Line Assembly (See Fig. 5)
15	1011603	1-1/2" Full Port Ball Valve
16	1014015	1-1/2" Galvanized Close Nipple
17	1011839	1-1/2" 90° Galvanized Street Elbow
18	1011833	1-1/4" x 1-1/2" x 1-1/2" Galvanized Pipe Tee
19	1012000	1" Abrasive Trap (See Literature 106M014)
20	1011901	1" Galvanized Square Head Pipe Plug
21	1011816	1" Galvanized Pipe Tee
22	1012151	1" Galvanized Close Nipple
—	106M071	Part Numbers & Schematics Guide – Blastmaster® 3.0 Cu. Ft. C-Series Abrasive Blasting Pot
—	1090071	Operator's Manual – Blastmaster® 3.0 Cu. Ft. C-Series Abrasive Blasting Pot
—	106M023	Part Numbers & Schematics Guide – Blastmaster® 150P Remote Control Switch
—	1090023	Operator's Manual – Blastmaster® 150P Remote Control Switch

# PART NUMBERS AND SCHEMATICS GUIDE

Figure 3: Blastmaster® 3.0 Cu. Ft. C-Series Abrasive Blasting Pot – Pneumatic

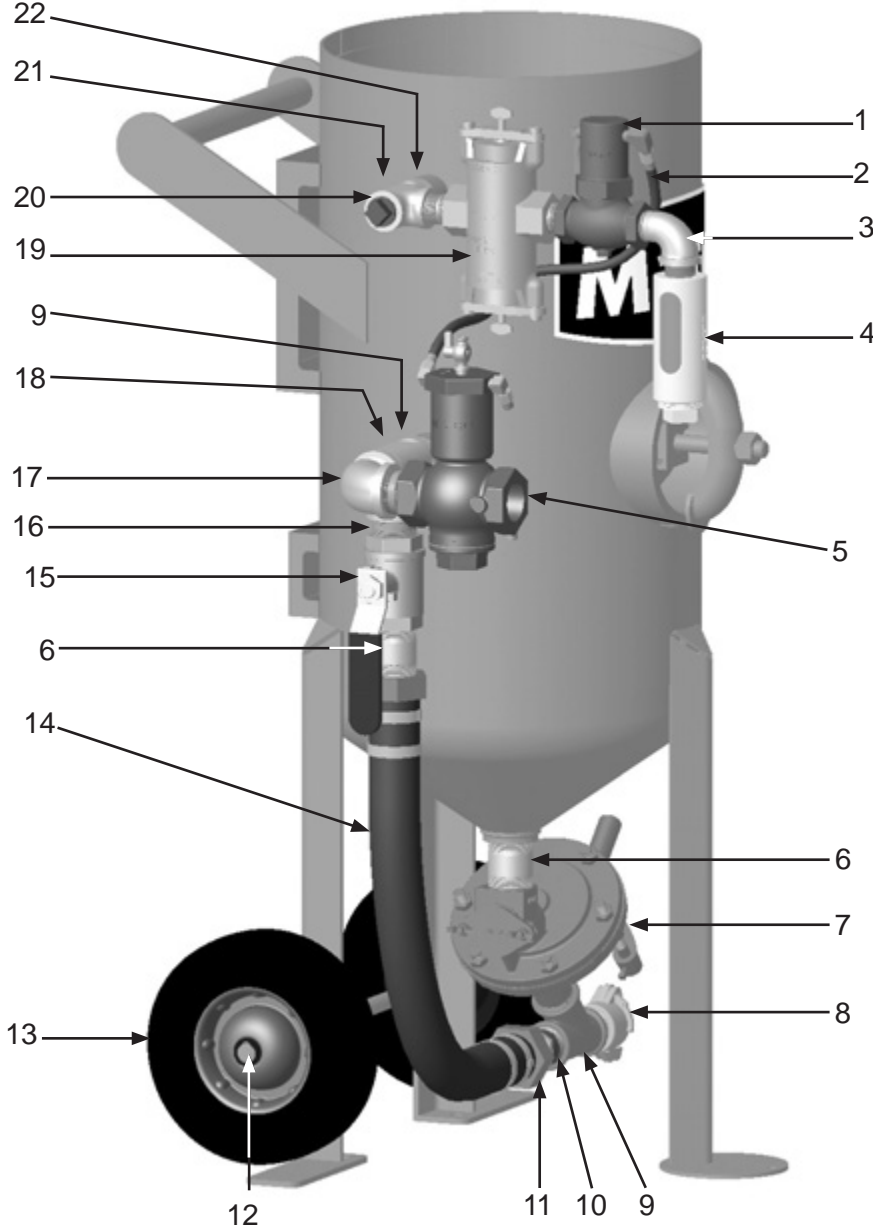

## PART NUMBERS AND SCHEMATICS GUIDE

### Blastmaster® 3.0 Cu. Ft. C-Series Abrasive Blasting Pot – Electric

Item #	Part #	Description
<b>Fig. 4</b>		
1	1012050	1" Outlet Valve
2	10CL18	18" Control Line
3	1011801	1" Galvanized Street Elbow
4	1011100	Abrasive Blasting Pot Muffler <i>(See Fig. 6)</i>
5	10TL5	5' Twinline
6	1012200	1-1/2" Inlet Valve
7	1011203	1-1/2" x 3" Galvanized Nipple <i>(Two Required)</i>
8	1014000	Blastmaster® Regulator Abrasive Metering Valve
9	10SB1	1-1/4" Brass Tank Coupling
10	1011201	1-1/4" Galvanized Close Nipple <i>(Two Required)</i>
11	1011206	1-1/4" x 2-1/2" Galvanized Nipple
12	1011501	1-1/2" (M) x 1-1/4" (F) Galvanized Hex Bushing
13	1006211	3/4" Wheel Clip <i>(Two Required)</i> for units built after March 2021
	1006205	1" Wheel Clip <i>(Four Required)</i> for units built before March 2021
14	10106067	10" Wheel <i>(Two Required)</i> for units built after March 2021
	1006064	16" Wheel <i>(Two Required)</i> for units built before March 2021
15	1006312	1-1/2" I.D. Pusher Line Assembly <i>(See Fig. 5)</i>
16	1011603	1-1/2" Full Port Ball Valve
17	1014015	1-1/2" Galvanized Close Nipple
18	1011839	1-1/2" 90° Galvanized Street Elbow
19	1011833	1-1/4" x 1-1/2" x 1-1/2" Galvanized Pipe Tee
20	1012000	1" Abrasive Trap
21	1019001	12-Volt DC 190 Electric Control Assembly
—	1019002	12-Volt AC 190 Electric Control Assembly
22	1011901	1" Galvanized Square Head Pipe Plug
23	1011816	1" Galvanized Pipe Tee
24	1012151	1" Galvanized Close Nipple
25	1019044	1/4-20 x 1-3/4" Zinc Bolt <i>(Two Required)</i>
26	1012323	1/4-20 Zinc Lock Nut with Nylon Insert <i>(Two Required)</i>
27	1030020	Blastmaster® 120VAC-12VAC Converter <i>(Optional)</i>
28	1012154	1/4-20 x 1" Hex Bolt <i>(Four Required)</i>
29	1014017	1/4" Flat Washer <i>(Four Required)</i>
—	106M063	Part Numbers & Schematics Guide – Blastmaster® 151E Remote Control Switch
—	106M071	Part Numbers & Schematics Guide – Blastmaster® 3.0 Cu. Ft. C-Series Abrasive Blasting Pot
—	1090063	Operator's Manual – Blastmaster® 151E Remote Control Switch
—	1090071	Operator's Manual – Blastmaster® 3.0 Cu. Ft. C-Series Abrasive Blasting Pot



# PART NUMBERS AND SCHEMATICS GUIDE

Figure 4: Blastmaster® 3.0 Cu. Ft. C-Series Abrasive Blasting Pot – Electric

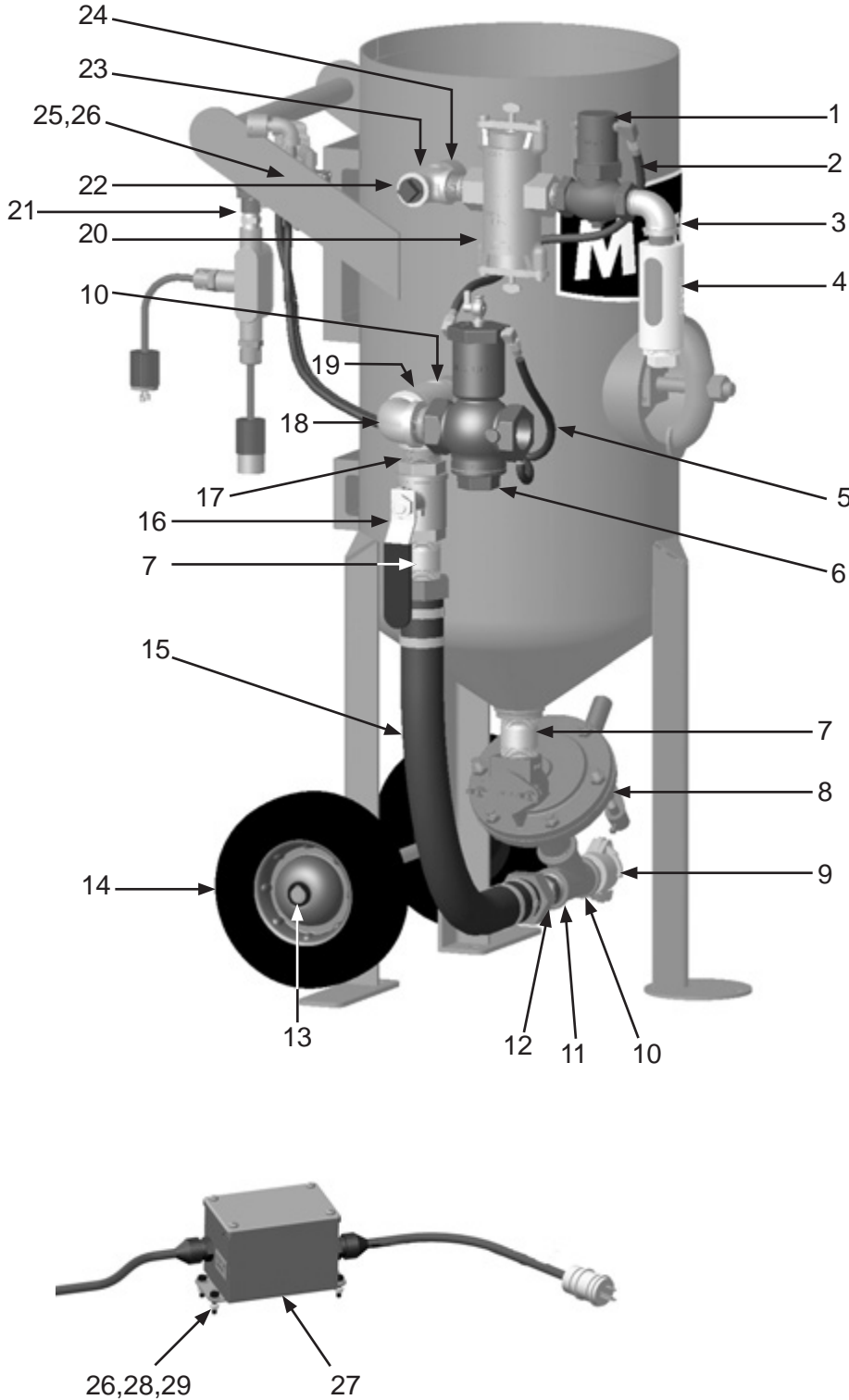

## PART NUMBERS AND SCHEMATICS

Figure 5: Pusher Line Assembly

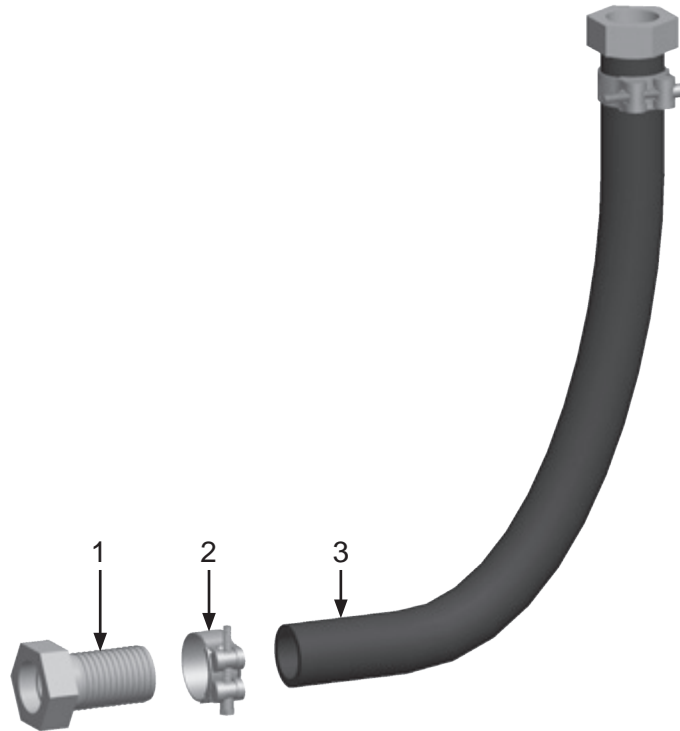

Item #	Part #	Description
--------	--------	-------------

Fig. 5

—	1006312	<b>1-1/2" I.D. Pusher Line Assembly</b> <i>Includes Item #: 1, 2, and 3 (Quantity of Three Feet)</i>
1	10SFE4	1-1/2" Female Swivel Air Hose End <i>(Two Required)</i>
2	10103738	1-1/2" T-Bolt Hose Clamp <i>(Two Required)</i>
3	10AH112B	1-1/2" I.D. Air Hose
—	10SFE4G	Gasket for 10SFE4 Swivel Air Hose End <i>(Not Shown)</i>
—	1090059	Technical Data Sheet – Pusher Line Assemblies

## PART NUMBERS AND SCHEMATICS

Figure 6: Exhaust Muffler Assembly

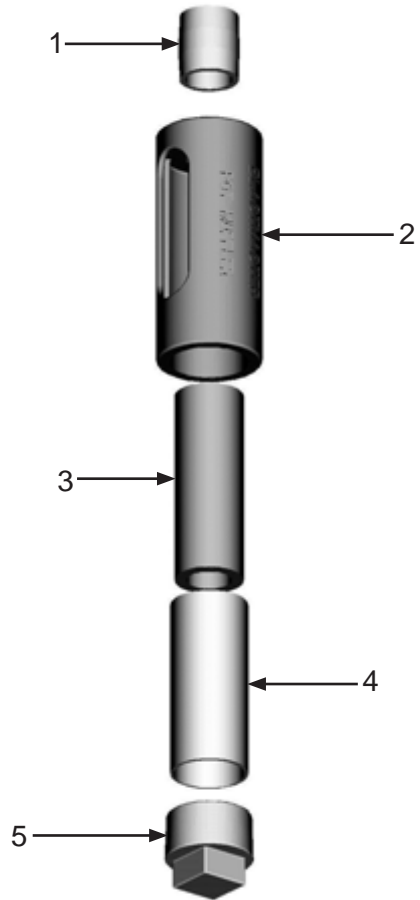

Item #	Part #	Description
<b>Fig. 6</b>		
—	<b>1011100</b>	<b>Blastmaster® Abrasive Blasting Pot Muffler – Complete</b>
1	1012151	1" Close Nipple
2	1011102	Body
3	1011103	Filter Element
4	1011104	Screen
5	1011101	1-1/2" Pipe Plug
—	1011105	Blastmaster® Abrasive Blasting Pot Muffler Service Kit <i>Includes Item #'s: 3 (Quantity of Three), 4, and 5</i>
—	105M347	Features and Specifications Guide – Blastmaster® Abrasive Blasting Pot Mufflers
—	106M347	Part Numbers And Schematics Guide – Blastmaster® Abrasive Blasting Pot Mufflers

## PART NUMBERS AND SCHEMATICS

### Blastmaster® 125P Remote Control System

Item #	Part #	Description
<b>Fig. 7</b>		
—	1012500	Blastmaster® 125P Remote Control System – Complete
1	1012000	Abrasive Trap – Complete <i>(see Figure 10)</i>
2	1012050	1" Outlet Valve – Complete <i>(see Figure 9)</i>
3	10CL18	Coupled Pneumatic Control Line – 18 Inches
4	10TL5	Coupled Pneumatic Control Line – 5 Feet
5	1017001	3/16" Control Line Union <i>(Two Required)</i>
6	10TL50	Coupled Pneumatic Control Line – 50 Feet
	10TL100	Coupled Pneumatic Control Line – 100 Feet <i>(optional)</i>
7	1015000	Blastmaster® 150P Remote Control Switch – Complete
8	1012200	1-1/2" Inlet Valve – Complete <i>(see Figure 8)</i>
—	1011501	1-1/2" NPT (M) x 1-1/4" NPT (F) Bushing <i>(Not Shown)</i>

## PART NUMBERS AND SCHEMATICS

Figure 7: Blastmaster® 125P Remote Control System

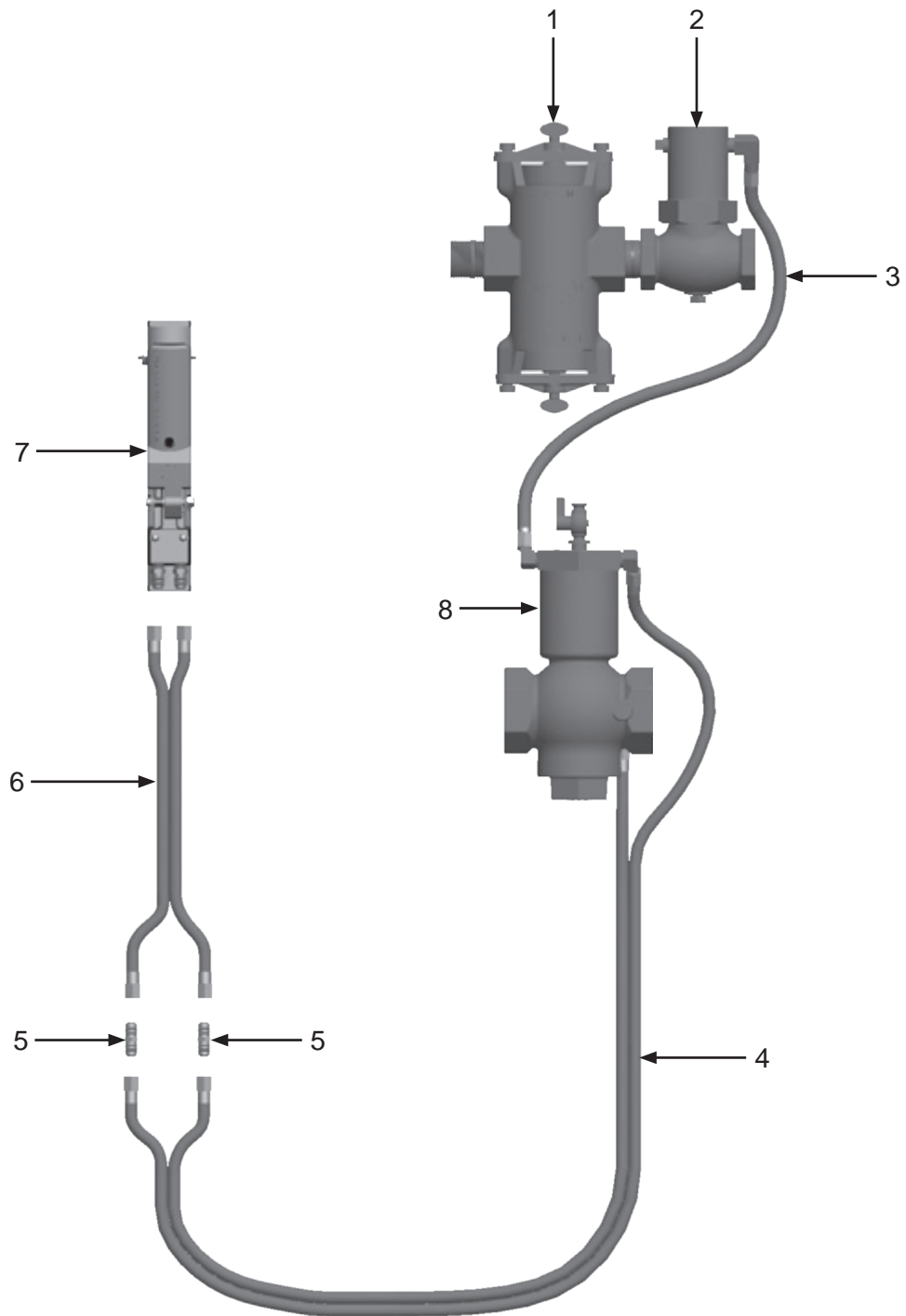

## PART NUMBERS AND SCHEMATICS

Figure 8: 1-1/2" Inlet Valve

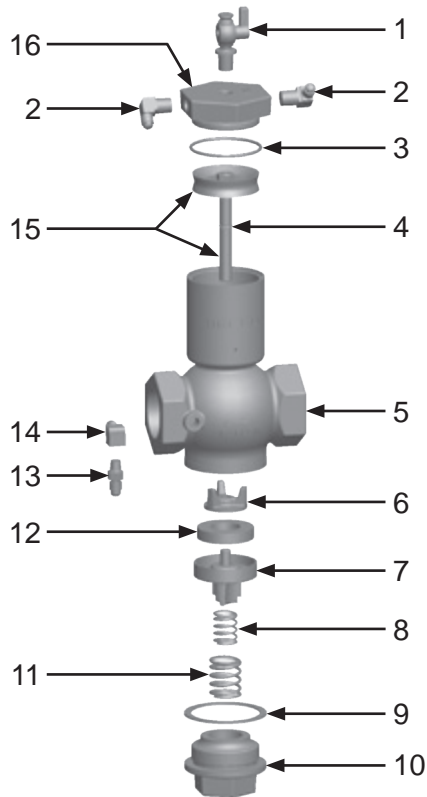

Item #	Part #	Description
<b>Fig. 8</b>		
—	1012200	1-1/2" Inlet Valve – Complete
1	1012101	1/4" NPT Petcock
2	1012051	1/4" NPT Brass Elbow ( <i>Two Required</i> )
3	1012213	1/8" x 2-1/2" O-ring
4	1012208	1/16" x 7/16" O-ring
5	1012204	1-1/2" Body
6	1012207	1-1/2" Plug Washer Retainer
7	1012205	1-1/2" Plug
8	1012105	5/8" x 1-11/16" Inner Spring
9	1012202	1-1/2" Bottom Cap Gasket
10	1012201	1-1/2" Bottom Cap
11	1012203	7/8" x 2-1/16" Outer Spring
12	1012206	1-1/2" Plug Washer
13	1012103	1/8" Adapter with 1/16" Restrictor Port
14	1012113	1/8" Street Elbow
15	1012209	Piston and Rod Assembly
16	1012214	1-1/2" Cylinder Cap
—	1012215	1-1/2" Inlet Valve Repair Kit (Includes Item #'s: 3,4,8,9,11, and 12 (Quantity of Two))

## PART NUMBERS AND SCHEMATICS

Figure 9: 1" Outlet Valve

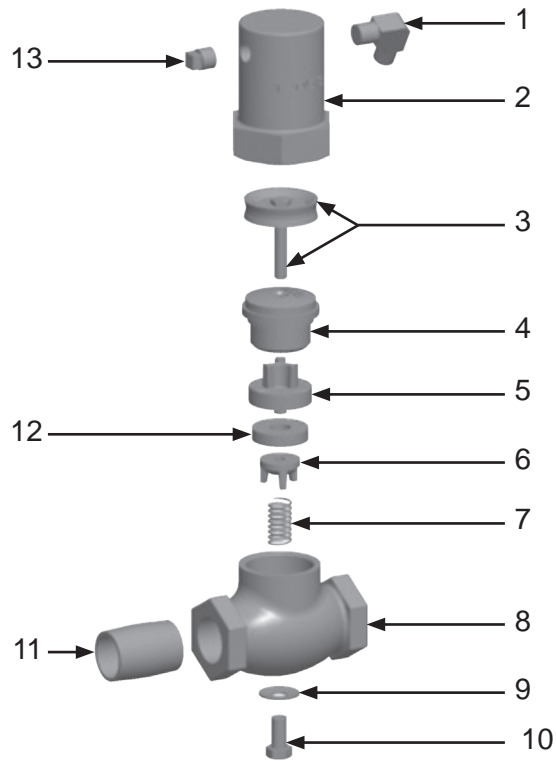

Item #	Part #	Description
<b>Fig. 9</b>		
—	1012050	1" Outlet Valve – Complete
1	1012051	1/4" x 1/4" Brass Elbow
2	1012053	Bonnet
3	1012054	Piston and Rod Assembly
4	1012058	Plug and Spindle Guide
5	1012059	Plug
6	1012061	Plug Washer Retainer
7	1012063	7/16" x 1-5/8" Spring
8	1012062	Body
9	1012064	3/8" Nylon Washer
10	1012065	3/8" x 3/4" Bolt
11	1012151	1" NPT Close Nipple
12	1012060	Plug Washer
13	1012052	1/4" NPT Pipe Plug
—	1012066	1" Outlet Valve Repair Kit (Includes Item #'s: 5,6,7,9,10, and 12 (Quantity of Two))

## PART NUMBERS AND SCHEMATICS

Figure 10: Abrasive Trap

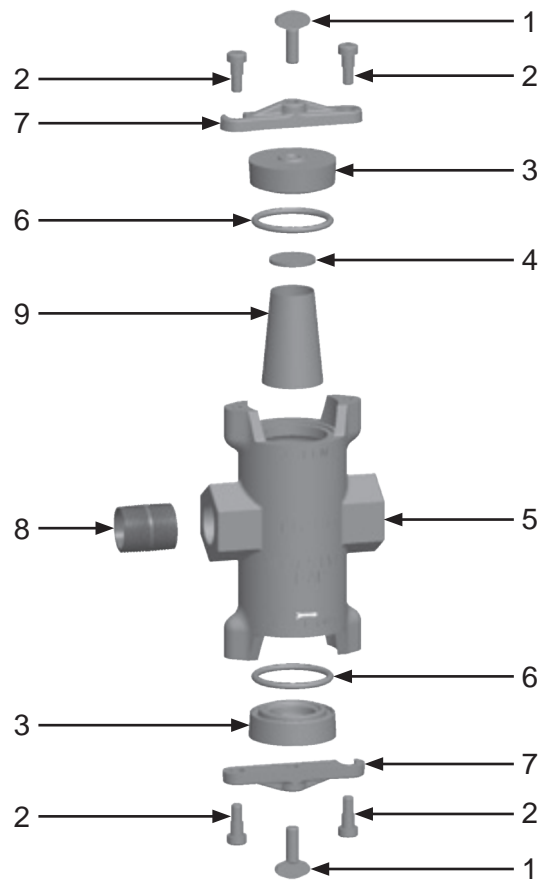

Item #	Part #	Description
Fig. 10		
—	1012000	Abrasive Trap – Complete
1	1012006	Thumb Screw ( <i>Two Required</i> )
2	1012007	3/8" x 3/8" Shoulder Bolt ( <i>Four Required</i> )
3	1012003	Abrasive Trap Cap ( <i>Two Required</i> )
4	1012008	Abrasive Trap Screen Gasket
5	1012004	Abrasive Trap Body
6	1012002	Abrasive Trap O-ring ( <i>Two Required</i> )
7	1012005	Cap Lock Bar ( <i>Two Required</i> )
8	1012151	1" NPT Close Nipple
9	1012001	Abrasive Trap Screen
—	1012009	Abrasive Trap Repair Kit (Includes Item #'s: 4,6 ( <i>Quantity of Two</i> ), and 9 ( <i>Quantity of Three</i> ))



## PART NUMBERS AND SCHEMATICS

Figure 11: 120-Volt AC to 12-Volt AC Power Converter

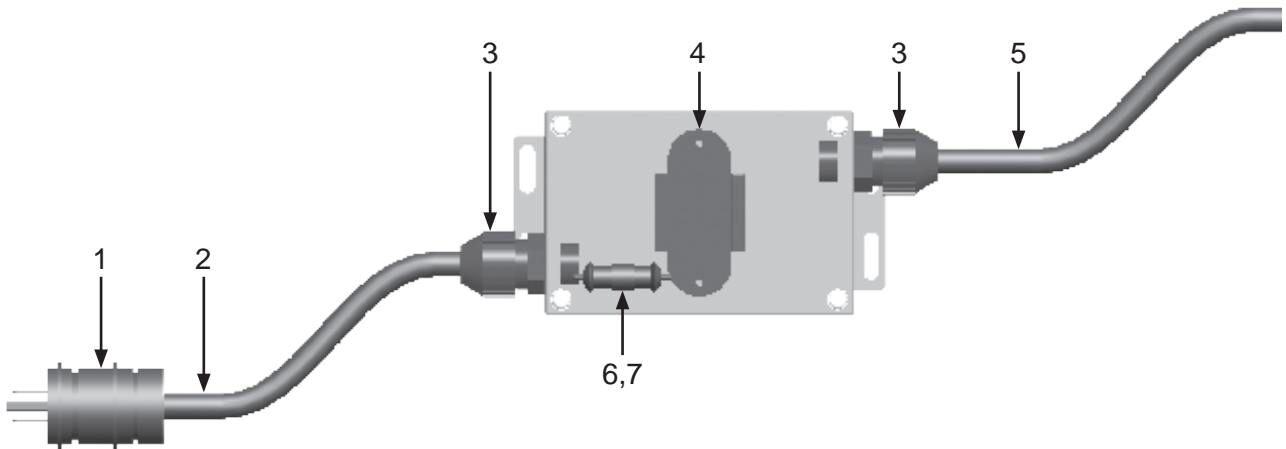

Item #	Part #	Description
Fig. 11		
—	1030020	Marco 120-Volt AC to 12-Volt AC Power Converter – Complete
1	1030026	3-prong, 120-Volt AC Plug – Male
2	1015550	14/3 SEOW Power Cord ( <i>Per Foot</i> )
3	1030025	Strain Relief ( <i>Two Required</i> )
4	1030022	Transformer – Marco 120-Volt AC to 12-Volt AC Power Converter
5	1030013	14/2 SEOW Power Cord ( <i>Per Foot</i> )
6	1030024	2 Amp Fuse
7	1030023	In-Line Fuse Holder
—	1030021	Resistor ( <i>Not Shown</i> )
—	1091063	Marco 120-Volt AC to 12-Volt AC Power Converter Hazard Identification Label
—	1091067	Power-Out Decal ( <i>Not Shown</i> )
—	1092014	Power-In Decal ( <i>Not Shown</i> )

## PART NUMBERS AND SCHEMATICS

### 12-Volt DC Blastmaster® 125E Remote Control System

Item #	Part #	Description
<b>Fig. 12</b>		
—	<b>1012551</b>	<b>12-Volt DC Blastmaster® 125E Remote Control System – Complete</b>
1	1012326	1/4" NPT 90° Swivel Fitting
2	1017019	1/4" X 1/4" Hex Nipple
3	10WS	Watts Strainer
4	1012051	1/4" NPT Brass Elbow <i>(Two Required)</i>
5	1012000	Abrasive Trap – Complete <i>(see Figure 19)</i>
6	1012050	1" Outlet Valve – Complete <i>(see Figure 18)</i>
7	1011501	1-1/2" NPT (M) x 1-1/4" NPT (F) Bushing
8	10TL5	Coupled Pneumatic Twinline Hose – 5 Feet
9	1012200	1-1/2" Inlet Valve – Complete <i>(see Figure 17)</i>
10	10CL18	Coupled Pneumatic Control Line – 18 inches
11	1015542	50 Feet of Electric Control Line with Male and Female Twist-Lock Plugs <i>(Includes Item #'s: 12, 13, and 14 (Quantity of 50 Feet))</i>
12	1015551	2-prong Twist-Lock Plug – Male
13	1015552	2-prong Twist-Lock Plug – Female
14	1015540	16/2 Power Cord – per foot
15	1015600	Blastmaster® 156E Remote Control Switch – Complete
16	1030718	Battery Clamps (pair)
17	1015541	Battery Clamp Kit <i>(Includes Item #'s: 13, 14 (Quantity of Two Feet), and 16)</i>
18	1015543	25 Feet of Electric Control Line with Male and Female Twist-Lock Plugs <i>(Includes Item #'s: 12, 13, and 14 (Quantity of 25 Feet))</i>
19	1019001	12-Volt DC 190 Electric Control Assembly <i>(See Figure 11)</i>

# PART NUMBERS AND SCHEMATICS

Figure 12: 12-Volt DC Blastmaster® 125E Remote Control System

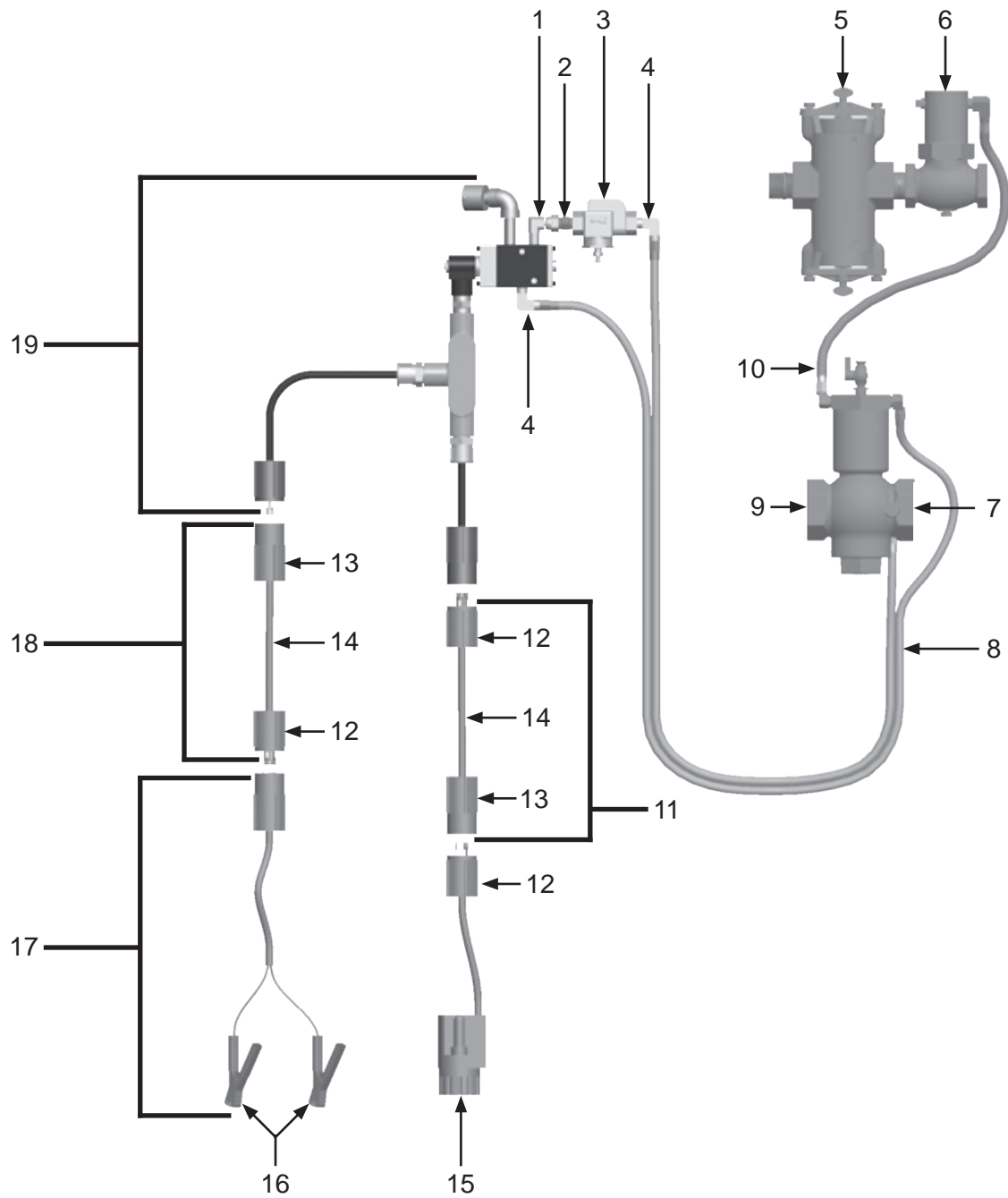

## PART NUMBERS AND SCHEMATICS

Figure 13: 12-Volt DC 190 Electric Control Assembly

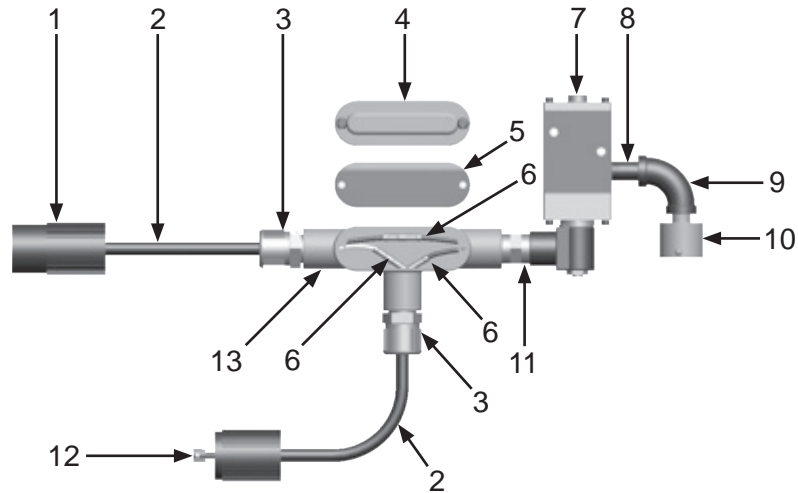

Item #	Part #	Description
<b>Fig. 13</b>		
—	<b>1019001</b>	<b>12-Volt DC 190 Electric Control Assembly – Complete</b>
1	1015552	2-prong Twist-Lock Plug – Female
2	1015540	16/2 Electric Cord – per foot
3	1019021	Cord Grip ( <i>Two Required</i> )
4	1019022	Conduit Box Cover
5	1019023	Conduit Box Cover Gasket
6	1030028	Butt Splicer
7	1019010	12-Volt DC Electric Solenoid – Complete ( <i>see Figure 12</i> )
8	1011217	1/4" x 2" Pipe Nipple
9	1011832	1/4" NPT 90° Pipe Nipple
10	10DE025	Dust Eliminator
11	20100677	1/2" x 1/2" NPT Hex Nipple
12	1015551	2-prong Twist-Lock Plug – Male
13	1090020	1/2" Tee Conduit Box

## PART NUMBERS AND SCHEMATICS

Figure 14: 12-Volt DC 190 Electric Solenoid

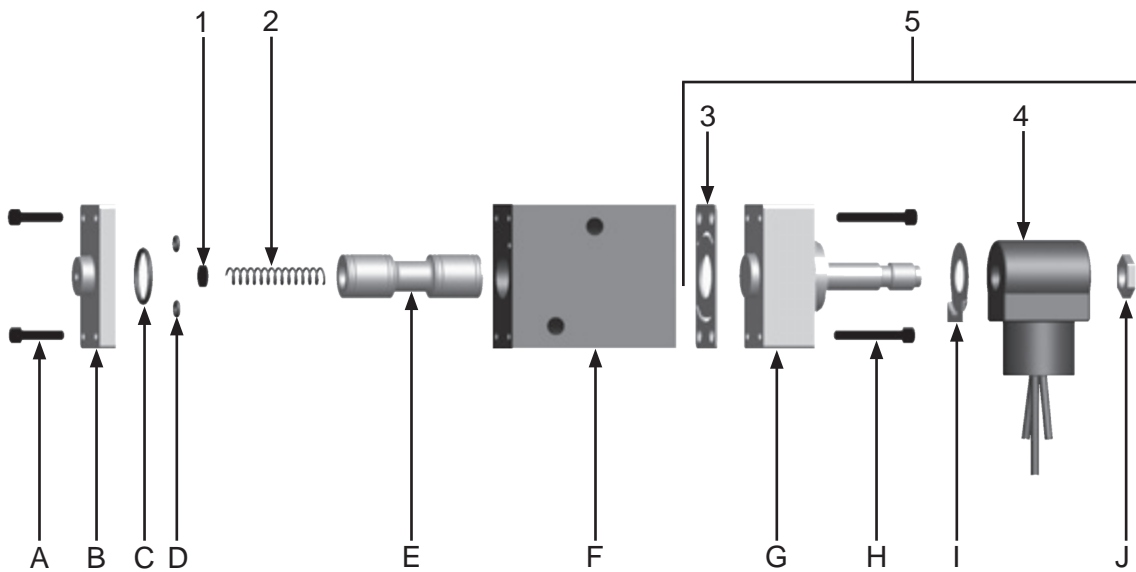

Item #	Part #	Description
--------	--------	-------------

Fig. 14

—	<b>1019010</b>	<b>12-Volt DC 190 Electric Solenoid – Complete</b>
---	----------------	--

1	1019029	Felt Filter
---	---------	-------------

2	1019032	Spring
---	---------	--------

3	1019033	Gasket
---	---------	--------

4	1019039	12-Volt DC Coil
---	---------	-----------------

5	1019034	12-Volt DC Operator Assembly (Includes Items: #3, #4, G, H, I, and J)
---	---------	--

—	1019030	Electric Solenoid Repair Kit (Includes Items: #1, #2, #3, C, D, and E)
---	---------	---

\* Items A–J are not available individually

## PART NUMBERS AND SCHEMATICS

### 120-Volt AC Blastmaster® 125E Remote Control System

Item #	Part #	Description
<b>Fig. 15</b>		
—	<b>1012552</b>	<b>120-Volt AC Blastmaster® 125E Remote Control System – Complete</b>
1	1012326	1/4" NPT 90° Swivel Fitting
2	1017019	1/4" X 1/4" Hex Nipple
3	10WS	Watts Strainer
4	1012051	1/4" NPT Brass Elbow <i>(Two Required)</i>
5	1012000	Abrasive Trap – Complete <i>(see Figure 19)</i>
6	1012050	1" Outlet Valve – Complete <i>(see Figure 18)</i>
7	1011501	1-1/2" NPT (M) x 1-1/4" NPT (F) Bushing
8	10TL5	Coupled Pneumatic Control Line – 5 Feet
9	1012200	1-1/2" Inlet Valve – Complete <i>(see Figure 17)</i>
10	10CL18	Coupled Pneumatic Control Line – 18 inches
11	1015542	50 Feet of Electric Control Line with Male and Female Twist-Lock Plugs <i>(Includes Item #'s: 12, 13, and 14 (Quantity of 50 Feet))</i>
12	1015551	2-prong Twist-Lock Plug – Male
13	1015552	2-prong Twist-Lock Plug – Female
14	1015540	16/2 Power Cord – per foot
15	1015600	Blastmaster® 156E Remote Control Switch – Complete
16	1030020	Marco 120-Volt AC to 12-Volt AC Power Converter <i>(see Figure 16)</i>
17	1019002	12-Volt AC 190 Electric Control Assembly <i>(see Figure 14)</i>







## PART NUMBERS AND SCHEMATICS

Figure 17: 12-Volt AC 190 Electric Solenoid

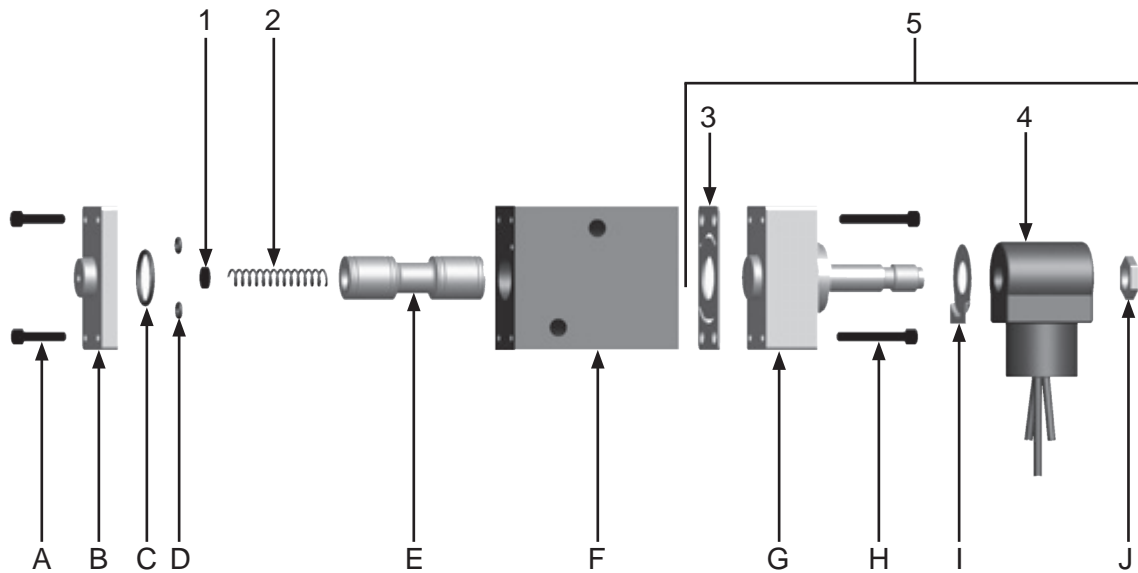

Item #	Part #	Description
<b>Fig. 17</b>		
—	<b>1019011</b>	<b>12-Volt AC 190 Electric Solenoid – Complete</b>
1	1019029	Felt Filter
2	1019032	Spring
3	1019033	Gasket
4	1019040	12-Volt AC Coil
5	1019035	12-Volt AC Electric Operator Assembly (Includes Items: #3, #4, G, H, I, and J)
—	1019030	12-Volt AC Electric Solenoid Repair Kit (Includes Items: #1, #2, #3, C, D, and E)
* Items A–J are not available individually		

## PART NUMBERS AND SCHEMATICS

### Blastmaster® Regulator Abrasive Metering Valve

Item # Part #

Fig. 18

Item #	Part #	Description
—	<b>1014000</b>	<b>Blastmaster® Regulator Abrasive Metering Valve – Complete</b>
1	1014022	1/2" Hex Nut ( <i>Eight Required</i> )
2	1014001	Upper Body
3	1014004	Body Gasket ( <i>Two Required</i> )
4	1014003	Valve Core
5	1014005	Stainless Disc
6	1014012	Shaft Gasket
7	1014002	Lower Body
8	1014021	1/2" x 1-3/4" Hex Bolt ( <i>Four Required</i> )
9	1014023	Packing Rope
10	1014011	Packing Gland
11	1012105	Spring (1-11/16" Long)
12	1014006	Heavy-Duty Handle
13	1014026	Pin
14	1014025	Pin Clip
15	1014024	1-1/4" "Y" Fitting
16	1011207	1-1/4" x 4" Nipple
17	1014010	Stud ( <i>Two Required</i> )
18	1014016	1/4" Wing Nut
19	1014017	1/4" Flat Washer
20	1014008	Spacer
21	1012154	1/4" x 1" Hex Bolt
22	1014018	1/4" x 1/2" Set Screw ( <i>Two Required</i> )
23	1014007	Gauge
24	1012112	2" O.D. x 1/8" O-ring
25	1014013	Inspection Plate
26	1014020	5/16" Wing Nut ( <i>Two Required</i> )
27	1014019	5/16" x 1-1/4" Bolt ( <i>Two Required</i> )
28	1014015	1-1/2" NPT Close Nipple
—	1091045	Hazard Identification Tag

# PART NUMBERS AND SCHEMATICS

Figure 18: Blastmaster® Regulator Abrasive Metering Valve

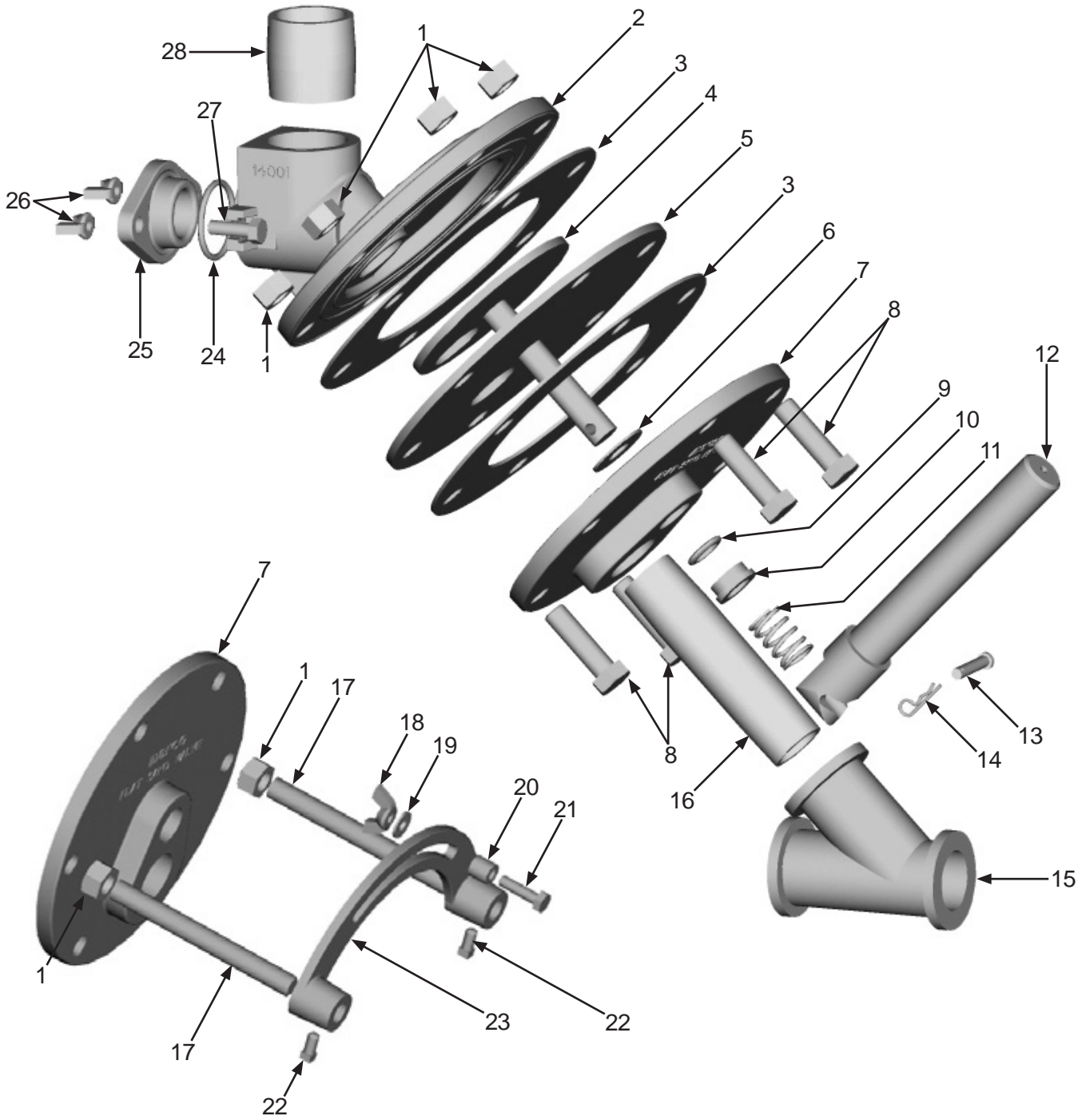

## OPTIONAL ACCESSORIES

**Figure 19: 1-1/4" Junior Extractor Abrasive Blasting Pot Moisture Separator**

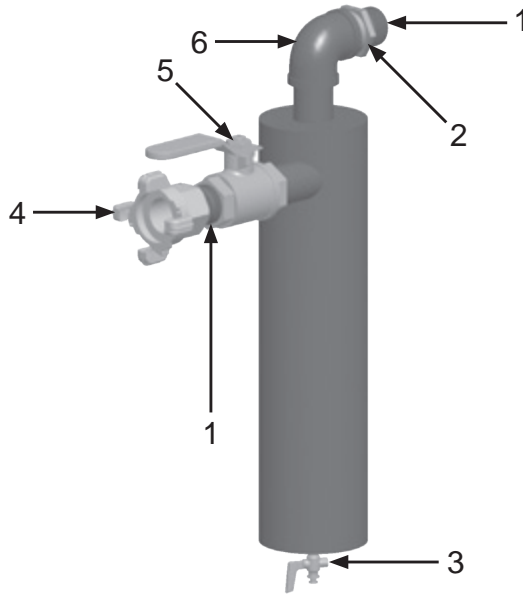

Item #	Part #	Description
<b>Fig. 19</b>		
—	10101314	1-1/4" Junior Extractor Abrasive Blasting Pot Moisture Separator
1	1011201	1-1/4" NPT Close Nipple ( <i>Two Required</i> )
2	1011501	1-1/2" x 1-1/4" Bushing
3	1012101	1/4" NPT Brass Petcock
4	10ME3	4-Lug Air Hose End – 1-1/4" NPT (F)
5	1011602	1-1/4" NPT Full Port Ball Valve
6	1006204	1-1/4" NPT 90° Elbow
—	105M039	Features and Specifications Guide – Abrasive Blasting Pot Moisture Separators
—	106M039	Part Numbers and Schematics Guide – Abrasive Blasting Pot Moisture Separators

## OPTIONAL ACCESSORIES

Figure 20: Lid and Screen

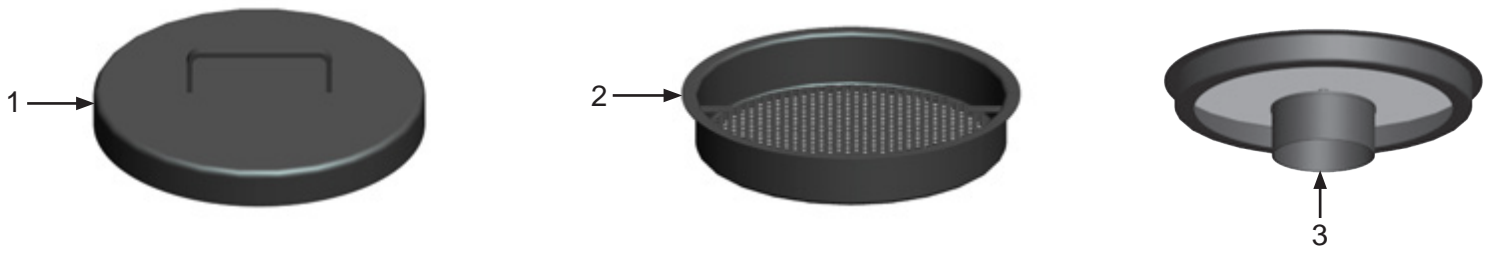

Item #	Part #	Description
1	1003101	16" Lid
2	1003102	16" Screen
3	10100732	Abrasive Umbrella (Screen Not Included)





## CONTACT CENTER

- 3425 East Locust Street  
Davenport, IA 52803

ph: 800.BLAST.IT (800.252.7848)  
ph: 563.324.2519  
fax: 563.324.6258

## REGIONAL BRANCH OFFICES

- Iowa  
Davenport
- Louisiana  
Gonzales  
Lafayette
- Ohio  
Youngstown
- Texas  
Beaumont  
Corpus Christi  
Deer Park

## 40+ NATIONWIDE SHIPPING LOCATIONS



★ Marco Regional Branch Offices  
and Shipping Locations

● Direct Shipping Locations



ABRASIVES

BLASTING

COATING

DUST COLLECTION

RENTAL & SERVICE

SAFETY

VACUUMS

## CONTACT MARCO

800.BLAST.IT  
(800.252.7848)  
563.324.2519  
FAX: 563.324.6258

WWW.MARCO.US  
SALES@MARCO.US