

OPERATOR'S MANUAL

BLASTMASTER® 153 REMOTE CONTROL VALVE

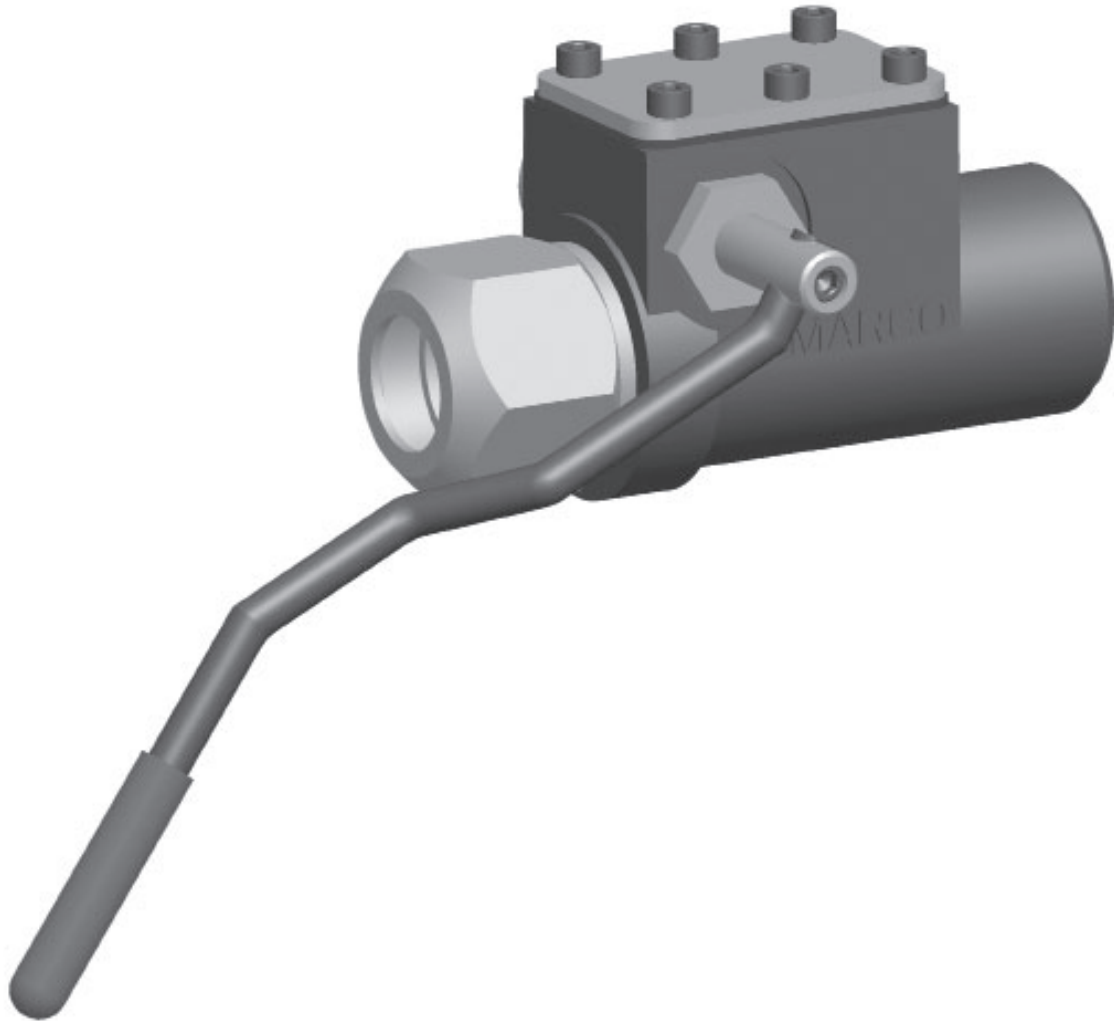

**BUILT MARCO
TOUGH**
MARCO MANUFACTURED

⚠ WARNING

Before using this equipment, read, understand and follow all instructions in the Operator's Manuals provided with this equipment. If the user and/or assistants cannot read or understand the warnings and instructions, the employer of the user and/or assistants must provide adequate and necessary training to ensure proper operation and compliance with all safety procedures pertaining to this equipment. If Operator's Manuals have been lost, please visit www.marco.us, or contact Marco at 563.324.2519 for replacements. Failure to comply with the above warning could result in death or serious injury.

Marco®

Company Profile

Since 1944, Marco has developed a strong tradition of providing innovative and reliable products and services to the surface preparation and protective coatings industries. We are the world's premier provider of Abrasives, Blasting Equipment, Coating and Painting Equipment, Engineered Systems, Rental Equipment, Safety Equipment, Service, and Repair.

Through innovative designs and a total commitment to quality, Marco manufactures products that increase production rates, create a safer workplace, and reduce maintenance costs. Marco's industry experience, manufacturing capabilities, legendary customer service, product availability, logistics services, and technology leadership is your assurance that we deliver high quality products and services, providing the best value to you, our customer.

The Marco Difference

- **Industry Experience** – With Marco on your team, you have access to expertise which can only come from decades of industry leadership. We have organized our engineering department, production specialists, customer operations, and safety support into a “Center of Competence.” As a Marco customer, you have access to hundreds of years of cumulative experience related to your operations.
- **Manufacturing Excellence** – Marco is a U.S. based, ISO 9001:2008 certified manufacturer of equipment for the Surface Preparation and Protective Coatings industries. Marco's engineers benchmark the industry to ensure that we design and manufacture superior products that set the “Gold Standard” for performance, safety, and quality.
- **Legendary Customer Service** – Marco's legendary customer service team is staffed by friendly, highly-trained individuals who are focused on providing the highest level of product support, order accuracy, and customer satisfaction.
- **Product Availability** – We stock over 10,000 SKU's and have over 45 shipping locations to serve North American and International markets for all major brands of blasting and painting equipment. As the largest provider of surface preparation and protective coatings equipment in the world, our inventory levels and product availability are unmatched.
- **Logistics Services** – Marco's in-house logistics team is dedicated to moving your shipment anywhere in the world. We move over 14,000 truckloads every year, allowing you to save on freight costs by leveraging our buying power. Lower your process costs with a single invoice, which includes product and freight.
- **Technology Leadership** – Our website provides: Operator's Manuals, Part Numbers and Schematics Guides, MSDS information, and Features, Advantages, and Benefits Guides, providing access to information 24/7. Our Extranet application allows you to receive quotes and place orders online. Our Intranet maintains a complete record of your purchase history to assist with ongoing support of your existing equipment and future purchasing decisions.

Vision Statement

Marco is the world's premier provider of Abrasives, Blasting Equipment, Coating and Painting Equipment, Engineered Systems, Rental Equipment, Safety Equipment, Service, and Repair.

Mission Statement

Marco provides strong leadership and innovation to the surface preparation and protective coatings industries. We dedicate our efforts to the continuous improvement of our products, services, processes, people, and most importantly, the quality of our customer's experience.

Quality Policy

Marco is committed to providing superior quality in the design, manufacturing, distribution, rental, service, and repair of our products. Our ISO 9001:2008 certification extends throughout all operations in all locations. Continuous improvement of our processes and supply chain Integration comprise the core of our business strategy for delivering exceptional quality and value in all Marco products and services.

Management Philosophy

We are a company dedicated to the success of every customer and associate. We discuss, debate, challenge, measure, and test our ideas. We will be boundless and limitless in our passion to improve. Through sound leadership and dedicated associates, we will ensure a long term, profitable future for Marco, our associates, customers, and suppliers.

TABLE OF CONTENTS

Company Profile	1	Limited Warranty	22
Operating Instructions	9	Disclaimer of Warranty	22
Description	9	Exclusive Remedy for Warranty Claims	22
Operational Requirements	9	Limitation of Remedies	22
Operating Instructions	9		
Installation	11		
Blastmaster® 153 Remote Control Valve	11		
Threaded Nozzle Conversion Kit	12		
Maintenance	13		
Disassemble and Assemble Blastmaster® 153 Remote Control Valve.	13		
Troubleshooting	15		
Assembly Part Numbers And Schematic	17		
Blastmaster® 153 Remote Control Valve	17		
Threaded Nozzle Conversion Kit	19		
Hose End Assemblies.	20		
Type I Ceramic Nozzles	20		

DEFINITION OF TERMS

DANGER

This is an example of danger. This indicates an imminently hazardous situation which, if not avoided, will result in death or serious injury.

CAUTION

This is an example of a caution. This indicates a potentially hazardous situation which, if not avoided, may result in minor or moderate injury. It can also be used to alert against unsafe practices.

WARNING

This is an example of a warning. This indicates a potentially hazardous situation which, if not avoided, could result in death or serious injury.

NOTICE

This is an example of a notice. This indicates policy or practice directly related to safety of personnel or protection of property.

HAZARD IDENTIFICATIONS

WARNING

Failure to comply with ANY WARNING listed below could result in death or serious injury.

- ▶ OSHA sets exposure limits to protect workers from exposure to respirable crystalline silica, 29 CFR 1910.1053. Airborne dust could increase the exposure levels beyond permissible limits. Breathing dust containing silica could cause silicosis, a fatal lung disease. Breathing dust during abrasive blasting operations, post-blast cleaning operations, and/or servicing equipment within the abrasive blasting area may expose an individual to conditions that could cause asbestosis, lead poisoning and/or other serious or fatal diseases. Harmful dust containing toxic material from abrasives or surfaces being abrasive blasted can remain suspended in the air for long periods of time after abrasive blasting has ceased. A NIOSH-approved, well-maintained, respirator designed for the specific operation being performed must be used by anyone abrasive blasting, handling or using the abrasive, and anyone in the area of the dust.
- ▶ Contact NIOSH and OSHA offices to determine the proper respirator for your specific application. The air supplied to the respirator must be at least Grade D quality as described in Compressed Gas Association Commodity Specification G-7.1 and as specified by OSHA Regulation 1910.134. Ensure air filter and respirator system hoses are not connected to non-air sources or in-plant lines that may contain nitrogen, oxygen, acetylene or other non-breathable gases. Before removing respirator, use an air monitoring instrument to determine if the atmosphere is safe to breathe.
- ▶ You must comply with all OSHA, local, City, State, Province, Country and jurisdiction regulations, ordinances and standards, related to your particular work area and environment. Keep unprotected individuals out of the work area.
- ▶ Abrasive blasting operators must receive thorough training on the use of abrasive resistant attire which includes: supplied-air respirator, abrasive blasting suit, safety shoes, gloves, ear protection and eye protection. Protect the operator and bystanders by complying with NIOSH and OSHA Safety Standards.
- ▶ Inspect all equipment for wear or damage before and after each use. Failure to use Original Equipment Manufacturer repair parts and failure to immediately replace worn or damaged components could void warranties and cause malfunctions.
- ▶ OSHA requires abrasive blasting nozzles be equipped with an operating valve, which shall be designed to be held open only by continuous hand pressure and shall close immediately upon release of hand pressure (i.e., a “deadman” control). The valve shall not be modified in any manner that would allow it to remain open without the application of continuous hand pressure by the operator. Failure to comply with the above warning could result in release of high speed abrasive and compressed air resulting in death or serious injury. OSHA 29CFR 1910.244(b)
- ▶ Point the abrasive blasting nozzle only at the surface being abrasive blasted. Never point the abrasive blasting nozzle or abrasive stream at yourself or others.
- ▶ Unless otherwise specified, maximum working pressure of abrasive blasting pots and related components must not exceed 150 psi. Exceeding maximum working pressure of 150 psi could cause the abrasive blasting pot and components to burst. Failure to comply with the above warning could result in death or serious injury.
- ▶ Never weld, grind or drill on the abrasive blasting pot (or any pressure vessel). Doing so will void ASME certification and manufacturer’s warranty. Welding, grinding or drilling on the abrasive blasting pot (or any pressure vessel) could weaken the vessel causing it to burst. Failure to comply with the above warning could result in death or serious injury. (ASME Pressure Vessel Code, Section VIII, Division 1)
- ▶ This equipment is not intended for use in any area that might be considered a hazardous location, as described in the National Electric Code NFPA 70, Article 500. Use of this equipment in a hazardous location could cause an explosion or electrocution.
- ▶ Never attempt to move an abrasive blasting pot containing abrasive. Never attempt to manually move abrasive blasting pots greater than 6.5 cubic foot capacity. Always use at least two capable people to manually move an abrasive blasting pot on flat, smooth surfaces. A mechanical lifting device must be used if an abrasive blasting pot is moved in any other manner.

HAZARD IDENTIFICATIONS

WARNING

Failure to comply with ANY WARNING listed below could result in death or serious injury.

- ▶ This product is not for use in wet environments. Always use a Ground Fault Interrupter Circuit (GFIC) for all electrical power source connections. Use of this product in wet environments could create a shock or electrocution hazard.
- ▶ Frozen moisture could cause restrictions and obstructions in pneumatic control lines. Any restriction or obstruction in the pneumatic control lines could prevent the proper activation and deactivation of the remote control system, resulting in the release of high speed abrasive and compressed air. In conditions where moisture may freeze in the control lines an antifreeze injection system approved for this application can be installed.
- ▶ Do not cut, obstruct, restrict or pinch pneumatic control lines. Doing so could prevent the proper activation and deactivation of the remote control system, resulting in the release of high speed abrasive and compressed air.
- ▶ Use of Marco remote control switches with other manufacturer's remote control systems could cause unintended activation of remote control systems resulting in the release of high speed abrasive and compressed air. Only Marco remote control switches should be used with Marco remote control systems.
- ▶ Always be certain to have secure footing when abrasive blasting. There is a recoil hazard when abrasive blasting starts that may cause user to fall and misdirect the abrasive stream at operator or bystander.
- ▶ Never use an abrasive blasting pot or attachments as a climbing device. The person could slip and fall. The abrasive blasting pot could become unstable and tip over.
- ▶ For equipment manufactured by entities other than Marco, you must consult the Original Equipment Manufacturer operator's manuals, information, training, instructions and warnings, for the proper and intended use of all equipment.
- ▶ Flammable fumes, such as solvent and paint fumes in the work area can present an ignition or explosion hazard if allowed to collect in adequate concentrations. To reduce conditions that could result in a fire or an explosion, provide adequate ventilation, eliminate all ignition or spark sources, keep the work area free of debris, store solvents and solvent contaminated rags in approved containers, follow proper grounding procedures, do not plug/unplug power cord or turn on/off power switches when flammable fumes are present, keep a working fire extinguisher or provide another fire suppression system in the work area. Cease all operations and correct condition if a spark or ignition source is identified during operation.
- ▶ Always depressurize the entire system, disconnect all power sources and lockout/tagout all components before any maintenance or troubleshooting is attempted. Failure to comply with the above warning could cause electrical shock and inadvertent activation of equipment resulting in death or serious injury.
- ▶ Moving parts can present an area where crushing, pinching, entanglement or amputation may occur. Do not place body parts or foreign objects in any area where there are moving parts.
- ▶ Surfaces of heated supply tanks, drums and/or lines as well as the adjoining plumbing may become hot during normal use. Do not touch these heated surfaces without proper protection. Deactivate and allow sufficient time for all surfaces to cool before attempting any maintenance.
- ▶ High-pressure fluid from gun, hose leaks, or ruptured components can pierce skin and can cause a serious injury that may result in amputation. Do not point gun or spray tip at anyone or at any part of the body. Keep clear of any leaks or ruptures. Depressurize the entire system before attempting cleaning, inspecting, or servicing equipment.
- ▶ Exposure to toxic fluids or fumes may occur during the normal operation of this system. Before attempting to fill, use, or service this system, read SDS's to know the specific hazards of the fluids you are using. Always use proper Personal Protective Equipment when attempting to fill, use, or service this system.
- ▶ The use of this product for any purpose other than originally intended or altered from its original design is prohibited.
- ▶ Never hang objects from the abrasive blasting pot handle. Doing so may cause the abrasive blasting pot to become unstable and tip over.

HAZARD IDENTIFICATIONS

CAUTION

Failure to comply with ANY CAUTION listed below may result in minor or moderate injury.

- ▶ Static electricity can be generated by abrasive moving through the abrasive blasting hose causing a shock hazard. Prior to use, ground the abrasive blasting pot and abrasive blasting nozzle to dissipate static electricity.
- ▶ High decibel noise levels are generated during the abrasive blasting process which may cause loss of hearing. Ensure appropriate Personal Protective Equipment and hearing protection is in use.

NOTICE

Failure to comply with ANY NOTICE listed below could pose a hazard to personnel or property.

- ▶ See Air & Abrasive Consumption Chart for estimated abrasive consumption rates and required air flow (cubic feet per minute). Your system must meet these minimum requirements to ensure proper function and performance.
- ▶ Always use abrasive that is dry and properly screened. This will reduce the potential for obstructions to enter the remote control system, abrasive metering valve and abrasive blasting nozzle.
- ▶ Moisture build-up occurs when air is compressed. Any moisture within the abrasive blasting system will cause abrasive to clump, clogging metering valves, hoses and nozzles. Install an appropriately sized moisture separator at the inlet of the abrasive blasting system. Leave the moisture separator petcock slightly open to allow for constant release of water. If insufficient volume of air exists and petcock is unable to be left open (at all times) petcock should be opened frequently to release water.
- ▶ To reduce abrasive intrusion in the air supply hose, depressurize the abrasive blasting pot before shutting off air supply from compressor.
- ▶ Inspect abrasive blasting nozzle before placing into service. Damage to abrasive blasting nozzle liner or jacket may occur during shipping. If you receive a damaged abrasive blasting nozzle, contact your distributor immediately for replacement. Abrasive blasting nozzles placed into service may not be returned. Abrasive blasting nozzle liners are made of fragile materials and can be damaged by rough handling and striking against hard surfaces. Never use a damaged abrasive blasting nozzle.
- ▶ Abrasive blasting at optimal pressure for the abrasive used is critical to productivity. Example: For an abrasive with an optimal abrasive blasting pressure of 100 psi at the abrasive blasting nozzle, one pound per square inch of pressure loss will reduce abrasive blasting efficiency by 1.5%. A 10 psi reduction in air pressure will cause a 15% loss of efficiency. Use a Needle Pressure Gauge to identify pressure drops in your system. Consult with your abrasive supplier for the requirements of your abrasive.
- ▶ Replace abrasive blasting nozzle if liner or jacket is cracked or damaged. Replace abrasive blasting nozzle if original orifice size has worn 1/16" or more. Determine abrasive blasting nozzle wear by inserting a drill bit 1/16" larger than original size of abrasive blasting nozzle orifice. If the drill bit passes through abrasive blasting nozzle, replacement is needed.

AIR & ABRASIVE CONSUMPTION CHART

NOTICE

Failure to comply with ANY NOTICE listed below could pose a hazard to personnel or property.

- ▶ See Air & Abrasive Consumption Chart for estimated abrasive consumption rates and required air flow (cubic feet per minute). Your system must meet these minimum requirements to ensure proper function and performance.
- ▶ When it comes to air & abrasive mixtures, more is not necessarily better. Optimum abrasive blasting efficiency takes place when a lean air & abrasive mixture is used. To correctly set the abrasive metering valve, begin with the valve fully closed and slowly increase the amount of abrasive entering the airstream. As you increase the abrasive flow, watch for a “blue flame” at the exit of the abrasive blasting nozzle. Faster cutting, reduced abrasive consumption and lower clean up costs, are benefits of the “blue flame”.
- ▶ Abrasive blasting at optimal pressure for the abrasive used is critical to productivity. Example: For an abrasive with an optimal abrasive blasting pressure of 100 psi at the abrasive blasting nozzle, one pound per square inch of pressure loss will reduce abrasive blasting efficiency by 1.5%. A 10 psi reduction in air pressure will cause a 15% loss of efficiency. Use a Needle Pressure Gauge to identify pressure drops in your system. Consult with your abrasive supplier for the requirements of your abrasive.



“Blue Flame”

NOTICE

Inspect abrasive blasting nozzle before placing into service. Damage to abrasive blasting nozzle liner or jacket may occur during shipping. If you receive a damaged abrasive blasting nozzle, contact your distributor immediately for replacement. Abrasive blasting nozzles placed into service may not be returned. Abrasive blasting nozzle liners are made of fragile materials and can be damaged by rough handling and striking against hard surfaces. Never use a damaged abrasive blasting nozzle.

Air & Abrasive Consumption Chart*

Nozzle Orifice	Pressure at the Nozzle (PSI)								Air (in cfm), Abrasive & Compressor Requirements
	50	60	70	80	90	100	125	140	
No. 2 (1/8")	11	13	15	17	18	20	25	28	Air (cfm)
	67	77	88	101	112	123	152	170	Abrasive (lbs/hr)
	2.5	3	3.5	4	4.5	5	5.5	6.2	Compressor Horsepower
No. 3 (3/16")	26	30	33	38	41	45	55	62	Air (cfm)
	150	171	196	216	238	264	319	357	Abrasive (lbs/hr)
	6	7	8	9	10	10	12	13	Compressor Horsepower
No. 4 (1/4")	47	54	61	68	74	81	98	110	Air (cfm)
	268	312	354	408	448	494	608	681	Abrasive (lbs/hr)
	11	12	14	16	17	18	22	25	Compressor Horsepower
No. 5 (5/16")	77	89	101	113	126	137	168	188	Air (cfm)
	468	534	604	672	740	812	982	1100	Abrasive (lbs/hr)
	18	20	23	26	28	31	37	41	Compressor Horsepower
No. 6 (3/8")	108	126	143	161	173	196	237	265	Air (cfm)
	668	764	864	960	1052	1152	1393	1560	Abrasive (lbs/hr)
	24	28	32	36	39	44	52	58	Compressor Horsepower
No. 7 (7/16")	147	170	194	217	240	254	314	352	Air (cfm)
	896	1032	1176	1312	1448	1584	1931	2163	Abrasive (lbs/hr)
	33	38	44	49	54	57	69	77	Compressor Horsepower
No. 8 (1/2")	195	224	252	280	309	338	409	458	Air (cfm)
	1160	1336	1512	1680	1856	2024	2459	2754	Abrasive (lbs/hr)
	44	50	56	63	69	75	90	101	Compressor Horsepower
No. 10 (5/8")	308	356	404	452	504	548	663	742	Air (cfm)
	1875	2140	2422	2690	2973	3250	3932	4405	Abrasive (lbs/hr)
	68.5	79.5	90	100.5	112	122	146	165	Compressor Horsepower
No. 12 (3/4")	432	504	572	644	692	784	948	1062	Air (cfm)
	2672	3056	3456	3840	4208	4608	5570	6238	Abrasive (lbs/hr)
	96	112	127	143	154	174.5	209	236	Compressor Horsepower

*Abrasive consumption is based on abrasive with a bulk density of 100 lbs per Cubic Foot

NOTICE

Replace abrasive blasting nozzle if liner or jacket is cracked or damaged. Replace abrasive blasting nozzle if original orifice size has worn 1/16" or more. Determine abrasive blasting nozzle wear by inserting a drill bit 1/16" larger than original size of abrasive blasting nozzle orifice. If the drill bit passes through abrasive blasting nozzle, replacement is needed.

"THE BIG PICTURE"

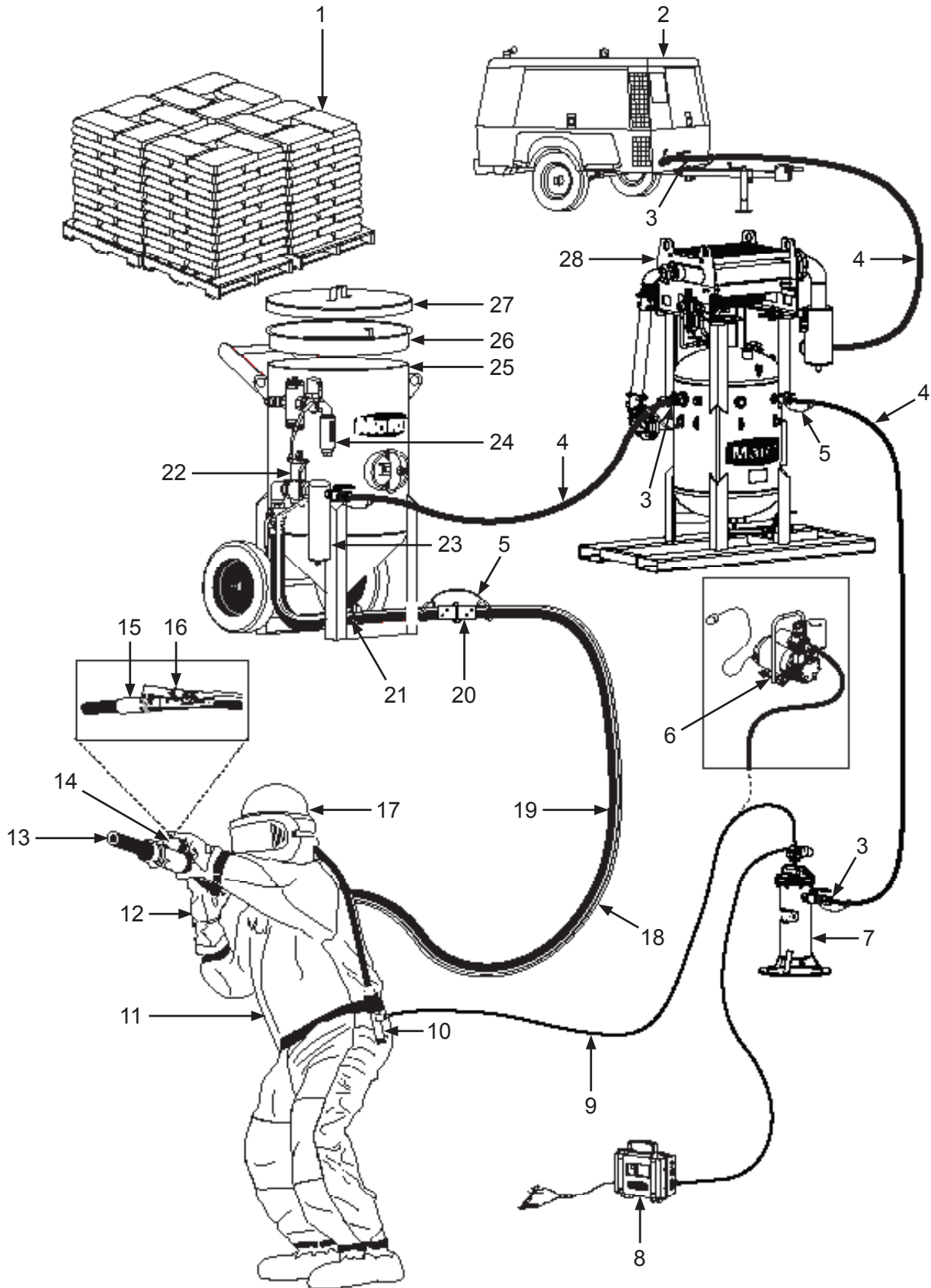

DAILY PRE-OPERATION CHECKLIST

Daily Pre-operation Checklist

- 1. Abrasive
- 2. Air Compressor
- 3. Air Hose Couplings & Gaskets
- 4. Air Hose
- 5. Safety Cable
- 6. Ambient Air Pump*
- 7. Breathing Air Filter
- 8. CO Monitor
- 9. Breathing Line
- 10. Climate Control Device
- 11. Abrasive Blasting Suit
- 12. Gloves
- 13. Abrasive Blasting Nozzle
- 14. Lighting System*
- 15. Abrasive Blasting Nozzle Holder
- 16. Remote Control Switch
- 17. Supplied-Air Respirator
- 18. Control Line
- 19. Abrasive Blasting Hose
- 20. Abrasive Blasting Hose Couplings & Gaskets
- 21. Abrasive Metering Valve
- 22. Remote Control System
- 23. Moisture Separator
- 24. Abrasive Blasting Pot Exhaust Muffler
- 25. Abrasive Blasting Pot
- 26. Abrasive Blasting Pot Screen
- 27. Abrasive Blasting Pot Lid
- 28. Aftercooler*

* *Optional or alternative device. Ask your Marco Representative for more details.*

Abrasive – Select the correct Abrasive (1) for the application. Review the SDS (*Safety Data Sheet*) to ensure the correct PPE (*Personal Protective Equipment*) and Environmental Controls have been selected and are in place.

Air Compressor – Select an Air Compressor (2) of adequate size to support all equipment requirements. Refer to “Air & Abrasive Consumption Chart” for Abrasive Blasting Nozzle (13) air consumption requirements. Before connecting Air Hose (4), sample the air being produced by the air compressor (2) to ensure it is free of petroleum contaminants.

Air Hose, and Air Hose Couplings & Gaskets – Select Air Hoses (4) of sufficient size to support all subsequent volumetric requirements and with a sufficient PSI (*pound per square inch*) rating. Inspect all Air Hoses (4), and Air Hose Couplings & Gaskets (3) for damage or wear. Repair or replace damaged or worn components.

Abrasive Blasting Hose, Abrasive Blasting Hose Couplings & Gaskets, and Abrasive Blasting Nozzle Holder – Select an Abrasive Blasting Hose (19) that has an inner diameter 3 to 4 times larger than your Abrasive Blasting Nozzle (13). Inspect Abrasive Blasting Hose (19), Abrasive Blasting Hose Couplings & Gaskets (20), and Abrasive Blasting Nozzle Holder (15) for damage or wear. Repair or replace damaged or worn components.

Safety Cables – Install a Safety Cable (5) at each Abrasive Blasting Hose (19), and Air Hose (4) connection points.

Aftercooler and Moisture Separator – Ensure Aftercooler (28) is positioned on stable ground. Keep petcock drain of Moisture Separator (23) slightly open during use. Drain both devices after each use.

Supplied-Air Respirator, Breathing Line, Breathing Air Filter, Climate Control Device, CO Monitor, Ambient Air Pump – You MUST consult the Operator’s Manual supplied with your Respiratory Equipment (6, 7, 8, 9, 10, 17) for ALL applicable instructions and warnings. Inspect all Respiratory Equipment components for damage or wear. Repair or replace damaged or worn components.

Abrasive Blasting Suit and Gloves – Select an abrasive-resistant Abrasive Blasting Suit (11) that is slightly oversized to allow ease of movement and allows air to flow around your body. Select abrasive-resistant Gloves (12) with a tight fit and a long cuff that overlaps the sleeve of the Abrasive Blasting Suit (11).

Abrasive Metering Valve and Abrasive Blasting Pot – Confirm Abrasive Blasting Pot (25) is positioned on stable ground. Inspect Abrasive Blasting Pot (25) and Abrasive Metering Valve (21) for damage or wear. Repair or replace damaged or worn components.

Abrasive Blasting Pot Screen and Abrasive Blasting Pot Lid – Always use an Abrasive Blasting Pot Screen (26) when filling Abrasive Blasting Pot (25) with Abrasive (1) to prevent debris from entering the Abrasive Blasting Pot (25). Remove Abrasive Blasting Pot Lid (27) before operating the Abrasive Blasting Pot (25). Install Abrasive Blasting Pot Lid (27) after use to protect the Abrasive Blasting Pot’s (25) interior.

Remote Control System, Remote Control Switch, Control Line, – Inspect Remote Control System (22) and Control Line (18) for damage or wear. Repair or replace damaged or worn components. Ensure Control Line (18) fittings connected to the Remote Control System (22) are tight and free of leaks. Ensure Remote Control Switch (16) is functioning properly. Consult Remote Control Switch Operator’s Manual for applicable instructions.

Abrasive Blasting Pot Exhaust Muffler – Inspect Abrasive Blasting Pot Exhaust Muffler (24) at start and end of daily use. Replace element of Abrasive Blasting Pot Exhaust Muffler (24) per Operator’s Manual instructions.

Lighting System – Ensure the Lighting System (14) is connected to a proper power supply before use.

OPERATING INSTRUCTIONS

WARNING

Use of Marco remote control switches with other manufacturer's remote control systems could cause unintended activation of remote control systems resulting in the release of high speed media and compressed air. Only Marco remote control switches should be used with Marco remote control systems. Failure to comply with the above warning could result in death or serious injury.

WARNING

OSHA requires blast nozzles be equipped with an operating valve, which shall be designed to be held open only by continuous hand pressure and shall close immediately upon release of hand pressure (i.e., a "deadman" control). The valve shall not be modified in any manner that would allow it to remain open without the application of continuous hand pressure by the operator. Failure to comply with the above warning could result in release of high speed media and compressed air resulting in death or serious injury. OSHA 29 CFR 1910.244(b)

WARNING

Do not wear loose clothing while operating Blastmaster® 153 Remote Control Valve or allow clothing to interfere with the operation of control valve. Failure to comply with the above warning could result in death or serious injury.

Description

The hose-end shutoff gives an operator the ability to remotely activate and deactivate the flow of air and abrasive at the blast nozzle. This increases productivity and eliminates the need for a pot tender. The Blastmaster® 153 Remote Control Valve is an OSHA-compliant blast hose-end shutoff valve. When the spring-assisted lever is moved to the blasting position, the air and abrasive mixture in the blast hose is released, allowing it to exit the blast nozzle. When the lever is released, it returns to the non-blasting position, deactivating the flow of the air and abrasive mixture exiting the blast nozzle. Common abrasives used include aluminum oxide, garnet, glass bead, mineral abrasives, and staurolite. Typical applications include monument engraving, touch-up work, automobile restoration, and construction equipment maintenance.

Operational Requirements

The following may cause safety hazards or reduced performance:

- Improper installation and/or maintenance of components.
- Use of anything other than hand pressure to activate remote control switch.
- Use of an air supply with pressure greater than 125 PSI.

Operating Instructions

Before using:

- Inspect all parts for signs of wear or damage. Remove Blastmaster® 153 Remote Control Valve from service if excessive wear or damage is found until parts can be replaced.
- Test Lever (5) by rotating it from Fully-Closed to Fully-Open. If Lever does not return to the Fully-Closed position, remove Blastmaster® 153 Remote Control Valve from service until device is repaired and operating properly.
- Make sure Blastmaster® 153 Remote Control Valve is securely attached to Nozzle Holder Base (4) and Nozzle Holder Base is securely attached to Hose End (6).
- Install Nozzle Washer in Outlet Port (A).
- Install Nozzle (2) (*not included*) in Nozzle Cap (1). See Installation Instructions.
- Ensure Nozzle Cap (1) is securely attached to Blastmaster® 153 Remote Control Valve.
- Pressurize the blast pot. (See blast pot Operator's Manual.)

During use:

- To operate, quickly swing Lever (5) from the Fully-Closed to the Fully-Open position. DO NOT use the Blastmaster® 153 Remote Control Valve to restrict the abrasive flow. Metering of the abrasive should occur at the abrasive metering valve on the abrasive blasting pot. Using the Blastmaster® 153 Remote Control Valve as a metering device will greatly increase the wear of parts.
- To cease operation, release Lever (5) and allow it to return to the Fully-Closed position.

After use:

- Depressurize blast pot. (See blast pot Operator's Manual.)
- Move Lever (5) to the Fully-Open position to release any residual pressure present in the blast hose.
- Remove Nozzle Cap (1) and Nozzle Washer (3). Extract Ceramic Nozzle (2) from Nozzle Cap.
- Remove Blastmaster® 153 Remote Control Valve from Nozzle Holder Base (4).
- Inspect parts for wear or damage. Replace parts showing excessive wear or damage before next use.

OPERATING INSTRUCTIONS

Blastmaster® 153 Remote Control Valve

⚠ WARNING

Always depressurize the entire system, disconnect all power sources and lockout/tagout all components before any maintenance or troubleshooting is attempted. Failure to comply with the above warning could cause electrical shock and inadvertent activation of equipment resulting in death or serious injury.

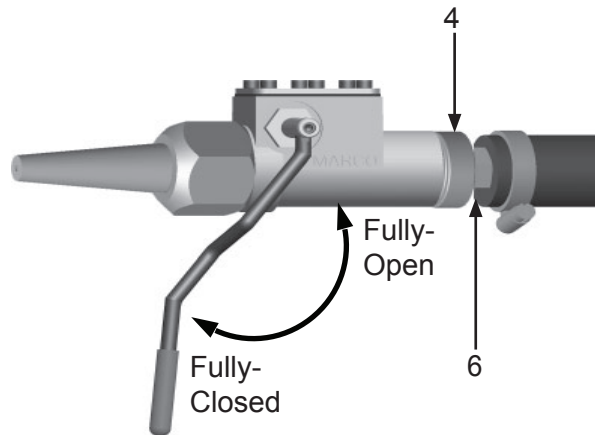
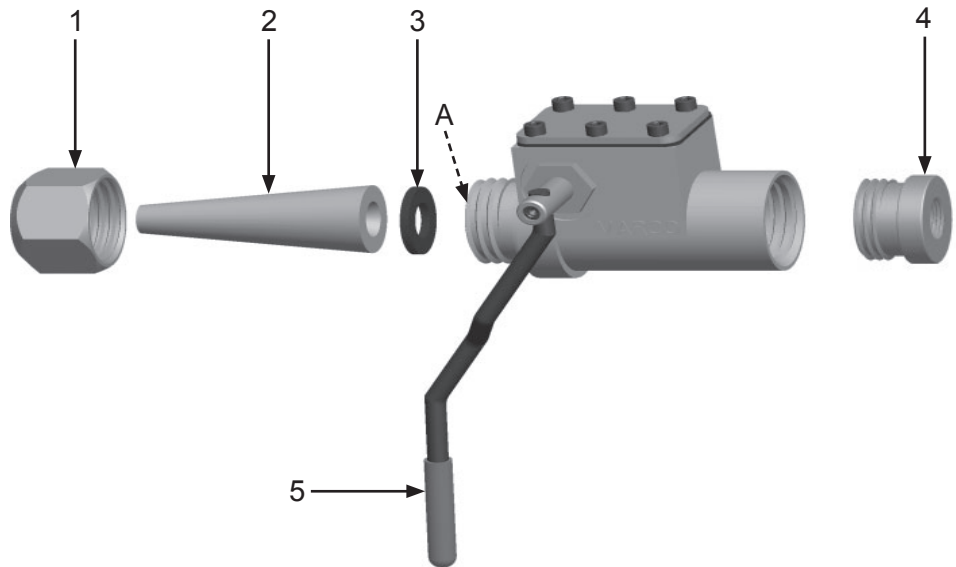

INSTALLATION

Blastmaster® 153 Remote Control Valve

WARNING

Always depressurize the entire system, disconnect all power sources and lockout/tagout all components before any maintenance or troubleshooting is attempted. Failure to comply with the above warning could cause electrical shock and inadvertent activation of equipment resulting in death or serious injury.

- 1) Install O-Ring (7) over threads of Nozzle Holder Base (8). Insert Rubber Liner (6) into Nozzle Holder Base.
- 2) Insert Ceramic Nozzle (2) into Nozzle Cap (1). Insert Nozzle Washer (3) into Valve Body (5).
- 3) Pull Lever (4) to the Fully-Open position and install Nozzle Cap Assembly on to Valve Body (5), ensuring a tight fit.

NOTE: A seal is formed between Valve Washer and Nozzle Washer (3) only when Nozzle Washer is properly installed with Ceramic Nozzle (2) and Nozzle Cap (1).

- 4) Install Valve Body (5) onto Nozzle Holder Base (8), assuring a tight fit.

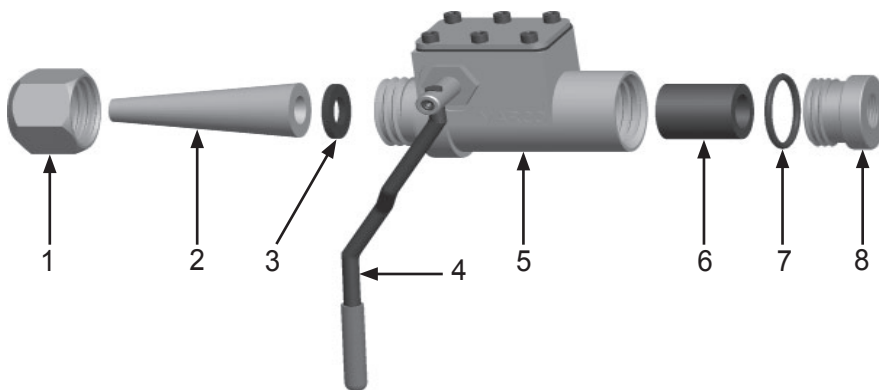

INSTALLATION

Threaded Nozzle Conversion Kit

⚠ WARNING

Always depressurize the entire system, disconnect all power sources and lockout/tagout all components before any maintenance or troubleshooting is attempted. Failure to comply with the above warning could cause electrical shock and inadvertent activation of equipment resulting in death or serious injury.

An optional Threaded Nozzle Adapter kit allows for use of standard threaded blast nozzles. These nozzles include liners that can provide longer operational life than ceramic nozzles.

- 1) Insert Nozzle Washer (2) into Valve Body (1).
- 2) Insert Spacer (3) into Valve Body (1), and install Threaded Adapter (5).
- 3) Insert Nozzle Washer (4), seating squarely against Spacer (3).
- 4) Pull Lever (7) to Fully-Open position and install Threaded Nozzle (6), tightening until seated.
- 5) Release Lever (7).

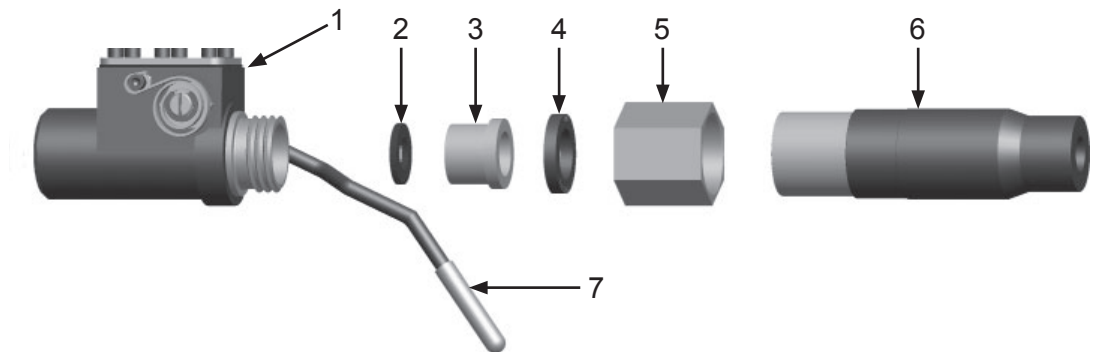

MAINTENANCE

Disassemble and Assemble Blastmaster® 153 Remote Control Valve

WARNING

Always depressurize the entire blasting system, disconnect all power sources and lockout/tagout all components before any maintenance or troubleshooting is attempted. Failure to comply with the above warning could cause electrical shock and inadvertent activation of equipment resulting in death or serious injury.

WARNING

The use of this product for any purpose other than originally intended or altered from its original design is prohibited. Failure to comply with the above warning could result in death or serious injury.

Maintenance of the Blastmaster® 153 Remote Control Valve is limited to the daily cleaning and the immediate replacement of damaged or worn parts.

Disassemble:

- 1) Remove Blastmaster® 153 Remote Control Valve from blast hose.
- 2) Remove Nozzle Holder Base (10) from Valve Body (7), if installed.
- 3) Remove Rubber Liner (8), and O-Ring (9) from Nozzle Holder Base (10).
- 4) Remove Nozzle Cap (1), Ceramic Nozzle (2), and Nozzle Washer (3) from Valve Body (7).
- 5) Remove six Hex Cap Screws (4), Cover (5), and Cover Gasket (6).
- 6) Remove E-clip (13) from Spindle (16).
- 7) Remove Hex Cap Screw (14), while holding Nut (15) in position, releasing Torsion Spring (12). Remove Torsion Spring.
- 8) Rotate Lever (11) until Shut-off Arm (18) extends through top opening and is accessible. Remove Hex Cap Screw (17). Remove Valve Washer (23), Rubber Washer (22), and Valve Disc Stem (21).
- 9) Remove Valve Washer (23) and Rubber Washer (22) from Valve Disc Stem (21).
- 10) Rotate Lever (11) until Shut-off Arm (18) makes contact with Valve Body (7) to expose Socket Screw (20). Remove Socket Screw and Star Lock Washer (19), releasing Shut-off Arm from Spindle (16).
- 11) Remove Set Screw (26) from Spindle (16), and remove Lever (11).
- 12) Unscrew Spindle Bushings (24) from Valve Body (7), and remove O-rings (25).
- 13) Inspect Valve Insert (27) for wear or damage. Replace as necessary.

Assemble:

- 1) Apply a light coat of blue thread locker to fine threads (c) on Valve Insert (27). Install Valve Insert into Valve Body (7).
- 2) Apply a light coat of petroleum jelly to O-Rings (25). Install into Spindle Bushings (24).
- 3) Apply a light coat of petroleum jelly to Spindle Hips (a). Loosely thread one Spindle Bushing (24) into Valve Body (7).
- 4) Install Spindle (16) by inserting shaft through Spindle Bushing (24).
- 5) Install remaining Spindle Bushing (24) by slipping it over Spindle (16). Loosely thread Spindle Bushing into Valve Body (7). Tighten Spindle Bushings.
- 6) Insert Lever (11) into Spindle (16). Lock Lever (11) in place with Set Screw (26).
- 7) Rotate Spindle (16) until notch (b) is visible and facing toward valve entry. Using Hex Screw (20) and Star Lock Washer (19), install Shut-off Arm (18).
- 8) Install Valve Washer (23) and Rubber Washer (22) onto Valve Disc Stem (21). Using Hex Cap Screw (17), install Valve Disc Stem Assembly onto Shut-off Arm (18).
- 9) Rotate Spindle (16) until Valve Stem Assembly is seated into Valve Insert (27). Insert inner tab of Torsion Spring (12) into slot on Spindle. Install E-Clip (13).
- 10) Insert Hex Cap Screw (14) through loop end of Torsion Spring (12). Install Nut (15) between Torsion Spring and Valve Body (7). Thread Hex Cap Screw (14) into Valve Body until base of the screw's cap aligns with E-Clip (13). Tighten Nut against Valve Body.
- 11) Stack Cover (5) over Cover Gasket (6), align over top Valve Body (7), and install with Hex Cap Screws (4).
- 12) Slip O-Ring (9) over threads on Nozzle Holder Base (10). Install Rubber Liner (8) into Nozzle Holder Base. Thread Nozzle Holder Base assembly into Valve Body (7).
- 13) Install Ceramic Nozzle (2) into Nozzle Cap (1). Install Nozzle Washer (3) into Valve Body (7).
- 14) Pull Lever (11) back to the Fully-Open position, then thread Nozzle Cap (1) onto Valve Body (7), ensuring a tight fit.

MAINTENANCE

Disassemble and Assemble Blastmaster® 153 Remote Control Valve

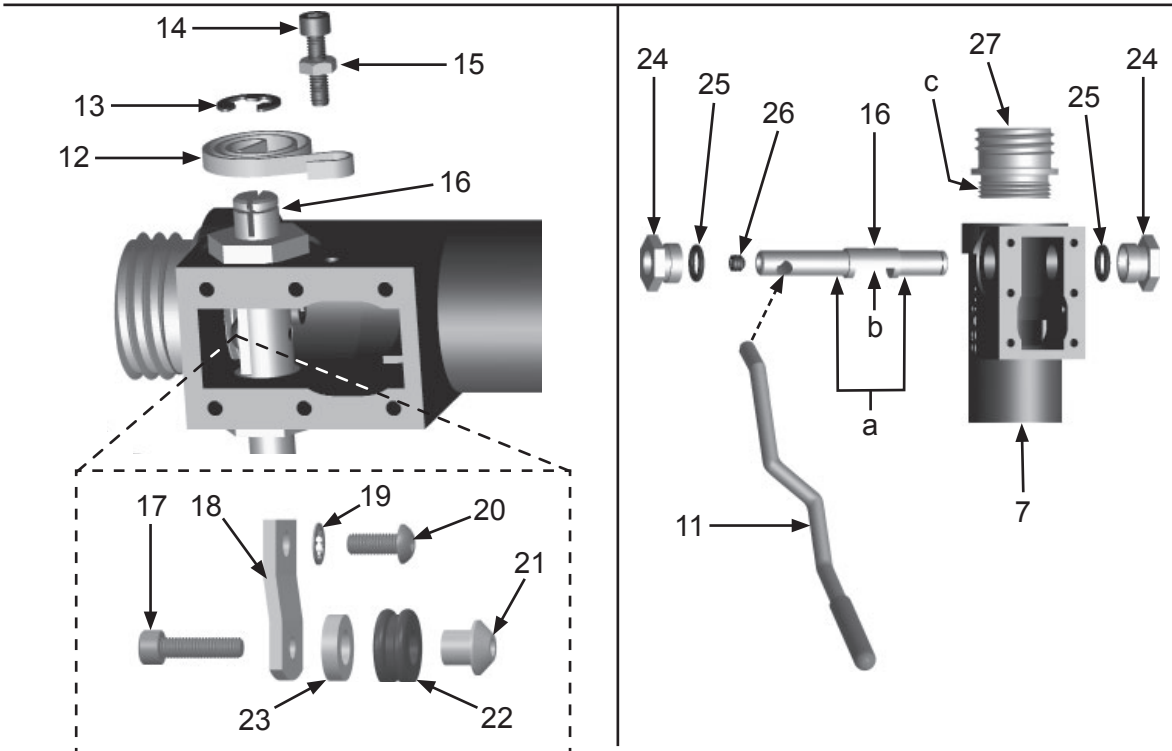
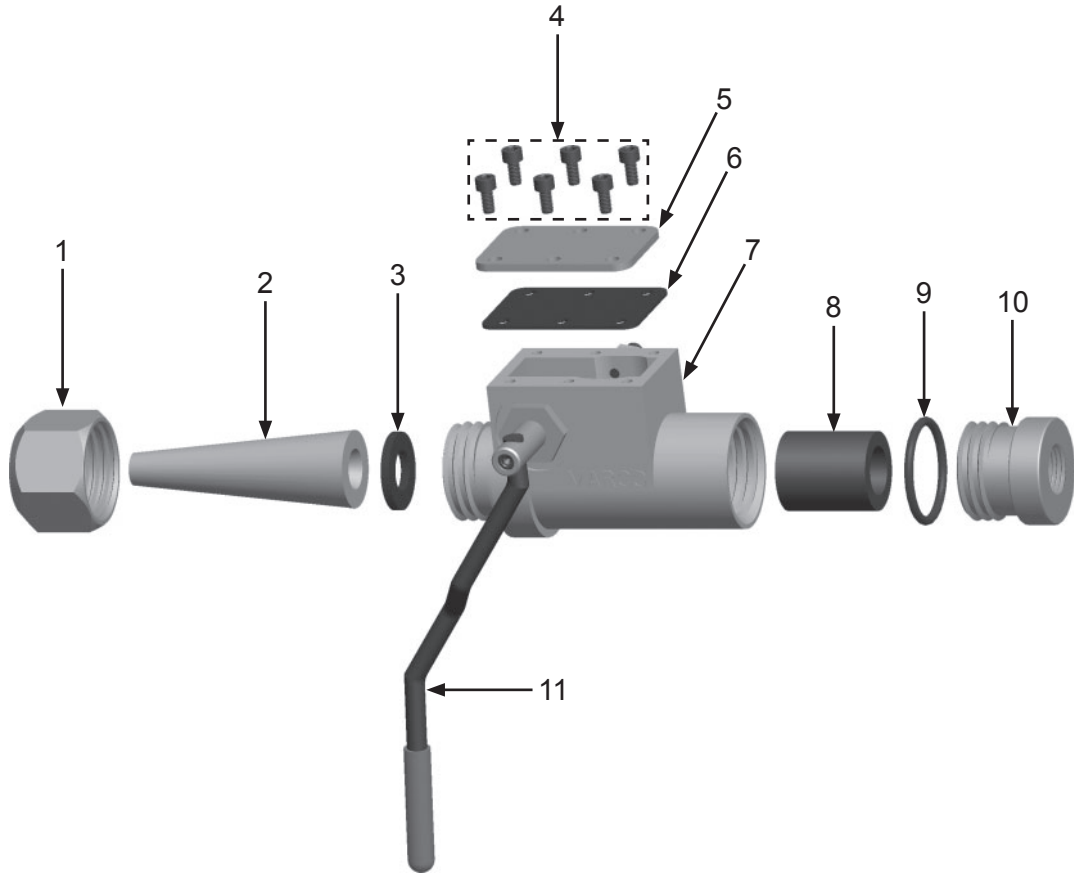

TROUBLESHOOTING

⚠ WARNING

Always depressurize the entire system, disconnect all power sources and lockout/tagout all components before any maintenance or troubleshooting is attempted. Failure to comply with the above warning could cause electrical shock and inadvertent activation of equipment resulting in death or serious injury.

⚠ WARNING

Unless otherwise specified, maximum working pressure of blast pots and related components must not exceed 125 PSI. Exceeding maximum working pressure of 125 PSI could cause the blast pots and components to burst. Failure to comply with the above warning could result in death or serious injury.

NOTICE

The Blastmaster® 153 Remote Control Valve is not designed to regulate the flow of air and media. Operating this valve in a partially open position will result in premature wear of internal components.

If the Blastmaster® 153 Remote Control Valve does not function properly, check the following:

SYMPTOM (Cause)

Remote Control Valve will not activate

(Damaged Components, Improper Assembly, Excessive Air Pressure)

ACTION

Internal components worn or damaged causing valve to not open. Depressurize blast pot, remove Blastmaster® 153 Remote Control Valve from blast hose and inspect for excessive wear or damage. Repair as necessary.

Abrasive can interfere with operation of valve. Remove cover and inspect interior of valve for clogged or packed abrasive. Use smaller sized abrasive.

During installation or maintenance, one or more components were improperly installed or have come loose. Depressurize blast pot, remove Blastmaster® 153 Remote Control Valve from blast hose and inspect for excessive wear or damage. Repair as necessary.

Air pressure over 125 PSI can make opening valve difficult. Reduce air pressure to make for easier activation.

See blast pot Operator's Manual.

TROUBLESHOOTING

If the Blastmaster® 153 Remote Control Valve does not function properly, check the following:

WARNING

Always depressurize the entire system, disconnect all power sources and lockout/tagout all components before any maintenance or troubleshooting is attempted. Failure to comply with the above warning could cause electrical shock and inadvertent activation of equipment resulting in death or serious injury.

WARNING

Unless otherwise specified, maximum working pressure of blast pots and related components must not exceed 125 PSI. Exceeding maximum working pressure of 125 PSI could cause the blast pots and components to burst. Failure to comply with the above warning could result in death or serious injury.

NOTICE

The Blastmaster® 153 Remote Control Valve is not designed to regulate the flow of air and media. Operating this valve in a partially open position will result in premature wear of internal components.

SYMPTOM (Cause)

ACTION

Remote Control Valve will not deactivate

(Damaged Components, Improper Assembly)

Internal components are worn or damaged causing valve to not close. Depressurize blast pot, remove Blastmaster® 153 Remote Control Valve from blast hose and inspect for excessive wear or damage. Repair as necessary.

Abrasive can interfere with operation of valve. Remove cover and inspect interior of valve for clogged or packed abrasive. Use smaller sized abrasive.

Torsion Spring is worn, damaged, or improperly installed. Inspect Torsion Spring, replace if damaged or excessively worn. See Disassemble and Assemble Instructions.

During installation or maintenance, one or more components were improperly installed or have come loose. Depressurize blast pot, remove Blastmaster® 153 Remote Control Valve from blast hose and inspect for excessive wear or damage. Repair as necessary.

See blast pot Operator's Manual.

ASSEMBLY PART NUMBERS AND SCHEMATIC

Blastmaster® 153 Remote Control Valve

Item #	Part #	Description
Fig. 1		
—	10L66EVD	Blastmaster® 153 Remote Control Valve – Complete
1	10L100164	Nozzle Cap <i>Use with Type I Ceramic Nozzles (See Figure 8)</i>
2	10L66CHW	Nozzle Washer for Ceramic Nozzle
3	10L805531	10-32 x 3/8" Socket Cap Screw <i>(Six Required)</i>
4	10L100170	Cover
5	10L66EVG	Cover Gasket
6	10L100018	Valve Body
7	10L800236	Rubber Liner – 3/4" I.D. Blast hose <i>(See Figure 7)</i>
8	10L66RR	O-ring
9	10L66VHD	Valve Lever <i>(Includes Item #15)</i>
10	10L66TB	Spindle Bushing <i>(Two Required)</i>
11	10L15300	Spindle O-ring <i>(Two Required)</i>
12	10L100134	Valve Insert
13	10L100070	Valve Spindle
14	10L800217	5/16-24 x 1/4" Spindle Set Screw
15	10L800338	Lever Grip
16	10L805034	Star Washer
17	10L800218	10-32 x 1/2" Hex Screw
18	10L66EVST	Valve Disc Stem
19	10L66RW	Rubber Valve Washer
20	10L66VW	Steel Shut-off Washer
21	10L100041	Shut-off Arm
22	10L805533	10-32 x 3/4" Hex Head Screw <i>(Two Required)</i>
23	10L66VSS	Torsion Spring
24	10L800149	Spindle E-clip
25	10L804322	10-32 Nut
—	10L66EVDR	Blastmaster® 153 Remote Control Valve Repair Kit <i>(Includes Item #'s: 3,6,7,8,16–19 (quantity of six),20,21,and 22 (quantity of two))</i>
—	105M034	Features and Specifications Guide – Blastmaster® 153 Remote Control Valve
—	106M034	Part Numbers and Schematics Guide – Blastmaster® 153 Remote Control Valve
—	1090034	Operator's Manual — Blastmaster® 153 Remote Control Valve
—	1091033	Cover Sticker
—	1091045	Hazard Identification Tag

ASSEMBLY PART NUMBERS AND SCHEMATIC

Figure 1: Blastmaster® 153 Remote Control Valve

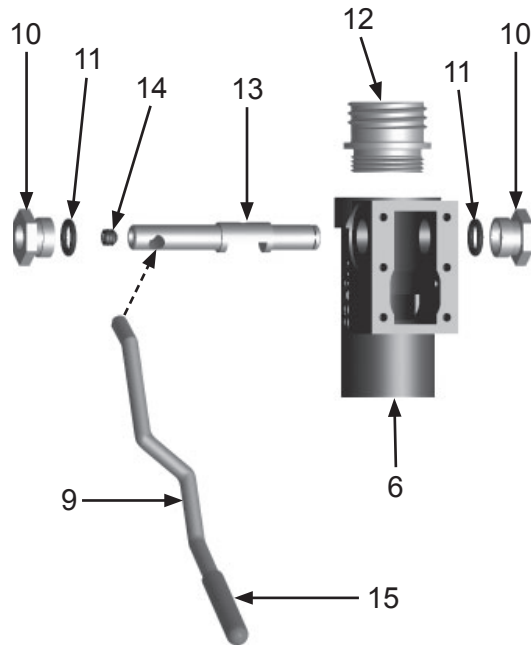
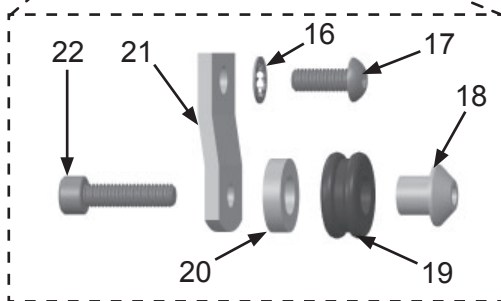
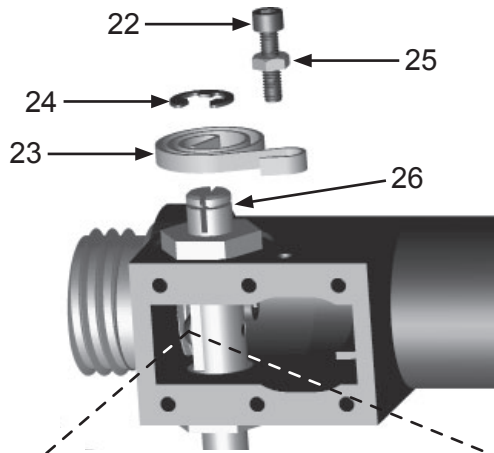
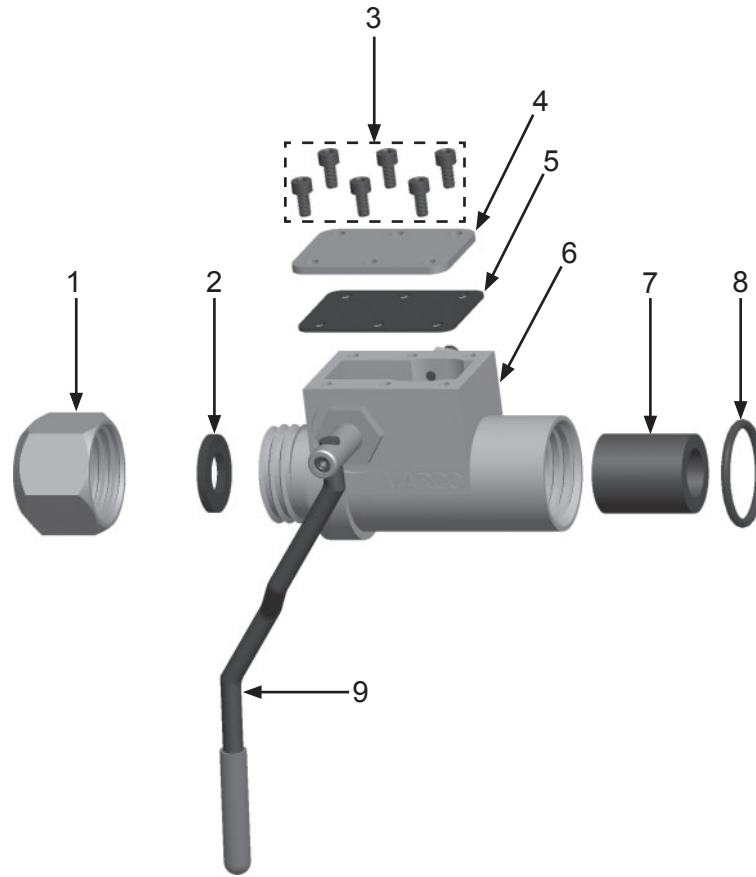

ASSEMBLY PART NUMBERS AND SCHEMATIC

Figure 2: Threaded Nozzle Conversion Kit

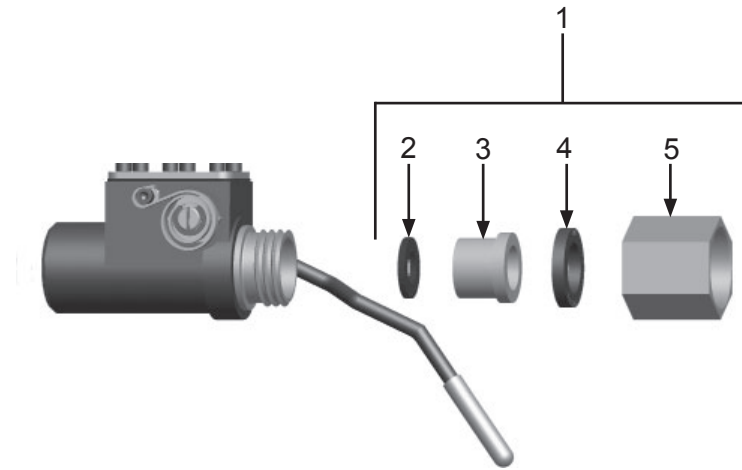

Item #	Part #	Description
Fig. 2		
1	10L100222	Threaded Nozzle Conversion Kit <i>(Includes Item #'s: 2,3,4,5)</i>
2	10L66CHW	Nozzle Washer
3	10L66HS	Spacer
4	10L850008	Nozzle Washer
5	10L66NCNV	Threaded Adapter
—	—	Threaded Nozzle <i>(Not Included. Contact Marco for details)</i>

ASSEMBLY PART NUMBERS AND SCHEMATIC

Figure 3: Hose End Assemblies

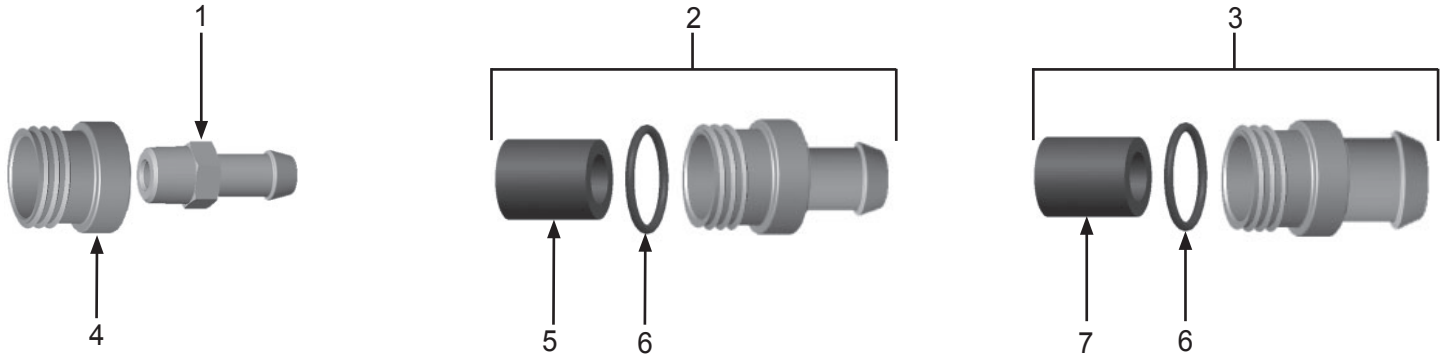

Item #	Part #	Description
--------	--------	-------------

Fig. 3

1	10L174	Hose End for 1/2" I.D. Blast hose
2	10L366HE	Hose End for 3/4" I.D. Blast hose <i>(Includes Item #'s: 5a and 6)</i>
3	10L466HE	Hose End for 1" I.D. Blast hose <i>(Includes Item #'s: 5b and 6)</i>
4	10L66B	Nozzle Holder Base
5	10L800236	Rubber Liner for 3/4" I.D. Blast hose
6	10L66RR	O-ring
7	10L800237	Rubber Liner for 1" I.D. Blast hose

Figure 3: Type I Ceramic Nozzles



TYPE I CERAMIC NOZZLES

Part Numbers	Size	Orifice Size	Nozzle Entry	Overall Length	Abrasive Mesh Size	Blast hose I.D.
10CN051	1	3/32"	5/8"	3-3/4"	100 Mesh or Finer	1/2"
10CN251	2	1/8"	5/8"	3-3/4"	60 Mesh or Finer	1/2"
10CN21251	2-1/2	5/32"	5/8"	3-3/4"	50 Mesh or Finer	1/2"
10CN351	3	3/16"	5/8"	3-3/4"	50 Mesh or Finer	3/4"
10CN451	4	1/4"	5/8"	3-3/4"	40 Mesh or Finer	3/4"
10CN551	5	5/16"	5/8"	3-3/4"	20 Mesh or Finer	1"
10CN651	6	3/8"	5/8"	3-3/4"	12 Mesh or Finer	1"

ADDITIONAL TECHNICAL DATA

The associations listed below offer information, materials and videos pertaining to abrasive blasting and safe operating practices.

- **American Society for Testing and Materials (ASTM)**
100 Barr Harbor Drive
West Conshohocken, PA 19428-2959
Phone: (610) 832-9585
FAX: (610) 832-9555
www.astm.org
- **Occupational Safety & Health Administration (OSHA)**
United States
Department of Labor
200 Constitution Avenue
Washington, DC 20210
Phone: (800) 321-OSHA
(800) 321-6742
www.osha.gov
- **The National Board of Boiler & Pressure Vessel Inspectors**
1055 Crupper Avenue
Columbus, Ohio 4322
Phone: (614) 888-8320
FAX: (614) 888-0750
www.nationalboard.org
- **National Association of Corrosion Engineers (NACE)**
1440 South Creek Drive
Houston, TX 77084-4906
Phone: (281) 228-6200
FAX: (281) 228-6300
www.nace.org
- **The Society for Protective Coatings (SSPC)**
40-24th Street, 6th Floor
Pittsburgh, PA 15222-4656
Phone: (412) 281-2331
FAX: (412) 281-9992
www.sspc.org
- **American National Standards Institute (ANSI)**
1899 L Street, NW, 11th Floor
Washington, DC 20036
Phone: (202) 293-8020
FAX: (202) 293-9287
www.ansi.org

LIMITED WARRANTY

Seller warrants to the original purchaser that the Product covered by this Limited Warranty will remain free from defects in workmanship or material under normal commercial use and service for a period of one year from the date of shipment to the original Purchaser. This Warranty shall not apply to defects arising, in whole or in part, from any accident, negligence, alteration, misuse or abuse of the Product, operation of the Product which is not in accordance with applicable instructions or manuals or under conditions more severe than, or otherwise exceeding, those set forth in the written specifications for the Product, nor shall this Warranty extend to repairs or alterations of the Product and/or any maintenance part by persons other than Seller or Seller's authorized representatives. This warranty does not apply to accessory items. Further, this Warranty does not apply to damage or wear to the surface finish or appearance of the Product or normal wear and tear to the Product. This Warranty is limited to a purchaser who purchases the Product either directly from the Seller or from one of Seller's "Authorized Distributors". An Authorized Distributor is a Seller approved distributor that purchases the Product directly from the Seller for the sole purpose of re-selling the Product at retail, without any use or modifications whatsoever, to an end-purchaser. This warranty is specifically non-assignable and non-transferable.

DISCLAIMER OF WARRANTY

The foregoing Limited Warranty is exclusive and is in lieu of all other warranties, whether oral or written and whether express, implied, or statutory. SELLER HEREBY DISCLAIMS ALL OTHER WARRANTIES, INCLUDING BUT NOT LIMITED TO THE WARRANTIES OF MERCHANTABILITY AND/OR FITNESS FOR A PARTICULAR PURPOSE AND ALL SUCH OTHER WARRANTIES ARE HEREBY EXCLUDED AND ARE INAPPLICABLE TO THE PRODUCT. Seller makes no warranties or representations of any kind concerning respirators, or equipment made by other manufacturers. Seller's agents and representatives are not authorized to offer any further warranties.

EXCLUSIVE REMEDY FOR WARRANTY CLAIMS

THE SOLE AND EXCLUSIVE REMEDY UNDER THE FOREGOING LIMITED WARRANTY, AND TO THE EXTENT PERMITTED BY LAW, ANY WARRANTY OR CONDITION IMPLIED BY LAW, COVERING THIS PRODUCT SHALL BE, AT THE SELLER'S OPTION, THE REPAIR OR REPLACEMENT, FREE OF CHARGE, F.O.B. POINT OF MANUFACTURE, OF ANY DEFECTIVE PART OR PARTS OF THE PRODUCT THAT WERE MANUFACTURED BY SELLER, AND WHICH ARE RETURNED TO SELLER AT SELLER'S PRINCIPAL PLACE OF BUSINESS, POSTAGE PREPAID BY THE PURCHASER. THIS SOLE AND EXCLUSIVE REMEDY IS CONDITIONED UPON PURCHASER'S PROMPT WRITTEN NOTICE TO SELLER AT SELLER'S PLACE OF BUSINESS THAT A DEFECT HAS BEEN DISCOVERED, TOGETHER WITH A REASONABLY DETAILED DESCRIPTION OF THE DEFECT IN THE PRODUCT, PROOF OF PURCHASE OF THE PRODUCT, AND THE MODEL AND IDENTIFICATION NUMBER OF THE PRODUCT WITHIN THIRTY (30) DAYS AFTER DISCOVERY OF THE DEFECT, OTHERWISE SUCH CLAIMS SHALL BE DEEMED WAIVED. NO ALLOWANCE WILL BE GRANTED FOR ANY REPAIRS OR ALTERATIONS MADE BY PURCHASER OR OTHERS WITHOUT SELLER'S PRIOR WRITTEN CONSENT. IF SUCH NOTICE IS TIMELY GIVEN, SELLER WILL HAVE THE OPTION TO EITHER MODIFY THE PRODUCT OR COMPONENT PART THEREOF TO CORRECT THE DEFECT, REPLACE THE PRODUCT OR PART WITH COMPLYING PRODUCTS OR PARTS, OR REFUND THE AMOUNT PAID FOR THE DEFECTIVE PRODUCT, ANY ONE OF WHICH WILL CONSTITUTE THE SOLE LIABILITY OF SELLER AND FULL SETTLEMENT OF ALL CLAIMS. IN NO EVENT SHALL SELLER BE LIABLE FOR ANY OBLIGATION GREATER THAN THE ORIGINAL PURCHASE PRICE OF THE PRODUCT UNDER THIS WARRANTY. PURCHASER SHALL AFFORD SELLER PROMPT AND REASONABLE OPPORTUNITY TO INSPECT THE PRODUCT FOR WHICH A CLAIM IS MADE. THE SOLE PURPOSE OF THE FOREGOING STIPULATED EXCLUSIVE REMEDY SHALL BE TO REPAIR OR REPLACE DEFECTIVE PRODUCTS OR COMPONENTS THEREOF, OR TO REFUND PURCHASER THE PURCHASE PRICE THEREOF. THIS STIPULATED EXCLUSIVE REMEDY SHALL NOT BE DEEMED TO HAVE FAILED OF ITS ESSENTIAL PURPOSE SO LONG AS SELLER IS WILLING AND ABLE TO REPAIR OR REPLACE THE DEFECTIVE PARTS OR REFUND THE PURCHASE PRICE IN ACCORDANCE WITH THE TERMS HEREOF. PRODUCTS THAT HAVE BEEN REPAIRED OR REPLACED UNDER THIS WARRANTY DO NOT RECEIVE A NEW WARRANTY AND ARE ONLY COVERED BY THE REMAINING PORTION OF THE ORIGINAL WARRANTY.

LIMITATION OF REMEDIES

The foregoing stipulated exclusive remedy is in lieu of all other remedies for breach of contract, warranty, and/or tort or otherwise. Seller shall not be liable, either directly or indirectly, for any consequential, incidental or special losses or damages of Purchaser, including but not limited to the Purchaser's expenses for downtime or for making up downtime, damages for which the Purchaser may be liable to other persons and/or entities, damages to property, and injury to or death of any persons and/or any claims for incidental or consequential damages, including but not limited to loss of profits, regardless of whether Seller has been informed of the possibility of such damages. Seller neither assumes, nor authorizes any person to assume for it, any other liability in connection with the sale or use of any Products covered by the foregoing Warranty and Disclaimers, and there are no oral agreements relating to remedies which are collateral to or which affect this limitation.

GLOBAL HEADQUARTERS

- 3425 East Locust Street
Davenport, IA 52803

ph: 800.BLAST.IT (800.252.7848)

ph: 563.324.2519

fax: 563.324.6258

GULF STATES HEADQUARTERS

- 701 East Boulevard
Deer Park, TX 77536

ph: 800.BLAST.IT (800.252.7848)

ph: 281.930.0905

fax: 281.542.0736

REGIONAL BRANCH OFFICES

- **Iowa**
Davenport
- **Louisiana**
Gonzales
Harvey
Lafayette
- **Ohio**
Youngstown
- **Texas**
Beaumont
Corpus Christi
Deer Park



ABRASIVES

BLASTING

COATING

DUST COLLECTORS

ENGINEERED SYSTEMS

RENTAL

SAFETY

SERVICE & REPAIR

VACUUMS

50+ NATIONWIDE SHIPPING LOCATIONS



★ Marco Regional Branch Offices
and Shipping Locations

● Direct Shipping Locations

CONTACT MARCO

800.BLAST.IT

(800.252.7848)

563.324.2519

FAX: 563.324.6258

WWW.MARCO.US

SALES@MARCO.US